

Department of Artificial Intelligence and Data Science

23EET103-Electric Circuits and
Electron Devices

I B.Tech. AIML / II SEMESTER

UNIT I : DC CIRCUITS

Topic 6 : Ideal and Practical Sources

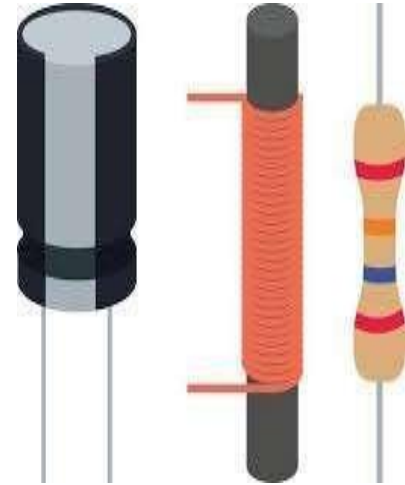

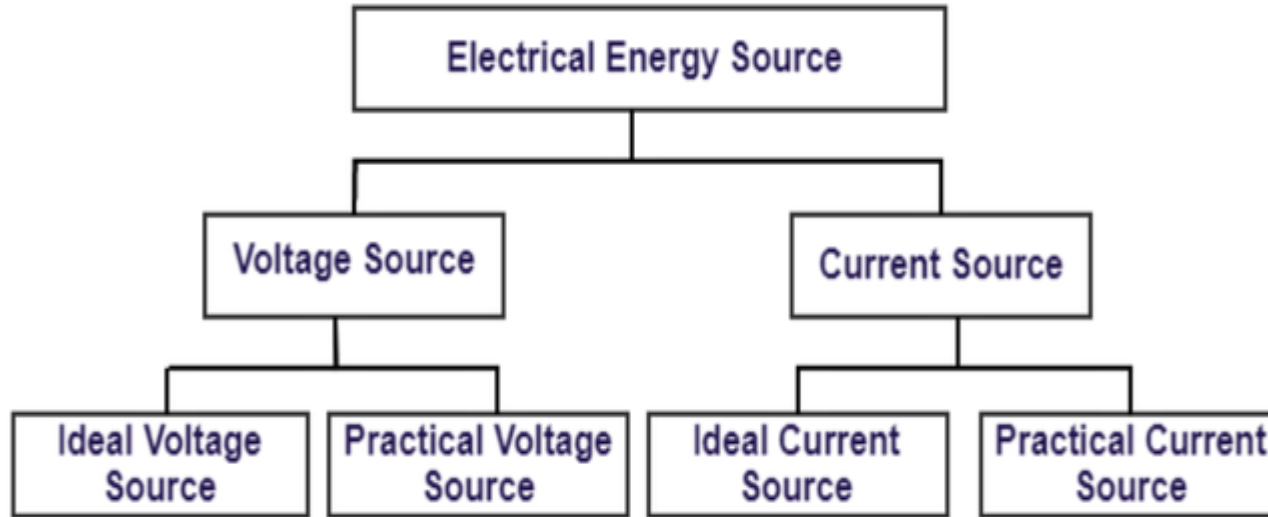

Ideal vs. Practical Sources in DC Circuits

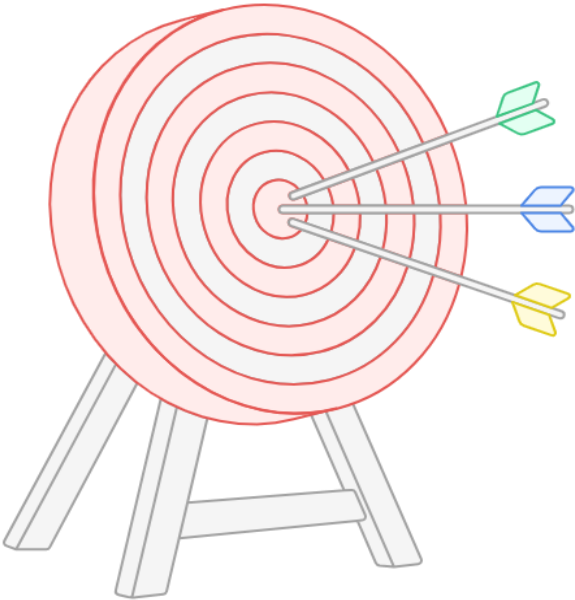

Accurate Circuit Analysis

Enables precise understanding of circuits



Practical Sources

Real-world components with limitations



Ideal Sources

Theoretical concepts without limitations

Made with  Napkin

Voltage sources

An **ideal voltage** source provides constant voltage at its terminal to the circuit regardless of the load current.

Practical voltage sources are real and used in daily life. A practical voltage source has internal resistance that causes a drop in terminal voltage due to the current flow.

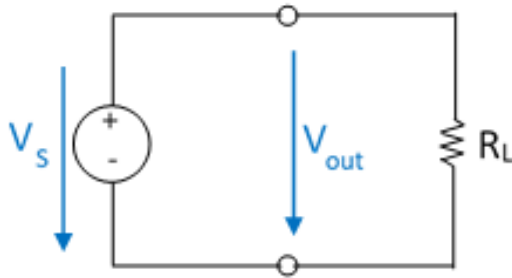

Ideal Voltage Source

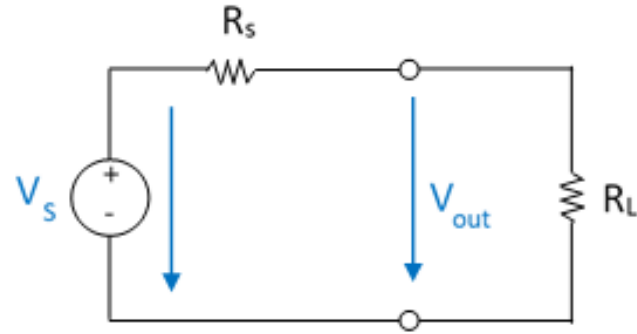

Practical Voltage Source

Current Sources

Ideal current sources are providing the exact same current to any resistance connected to it.

Where practical current sources may vary current resistance.

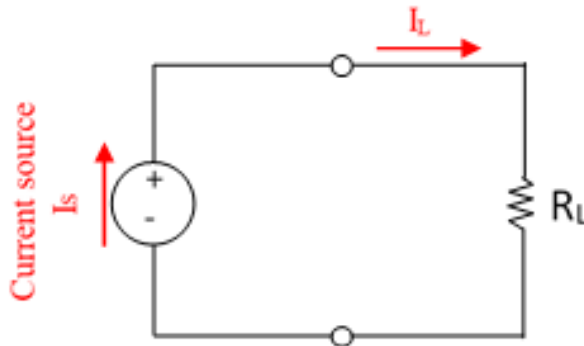

Ideal Current Source

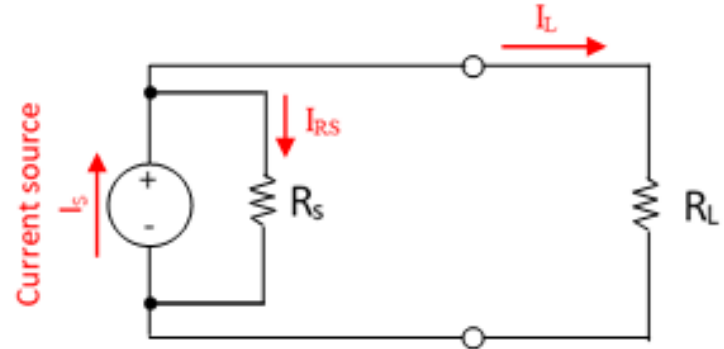

Practical Current Source

Ideal Voltage Source

Provides a constant voltage across its terminals, regardless of the current drawn from it.

Unveiling the Ideal Voltage Source

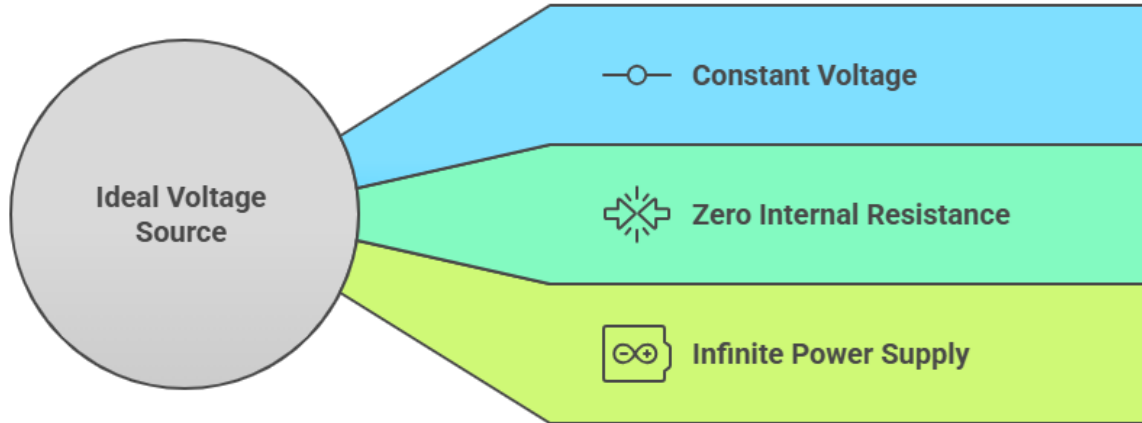

Made with  Napkin

Characteristics of an Ideal Voltage Source:

- **Constant Voltage**
- **Zero Internal Resistance**
- **Infinite Power Supply**

Characteristics of an Ideal Voltage Source

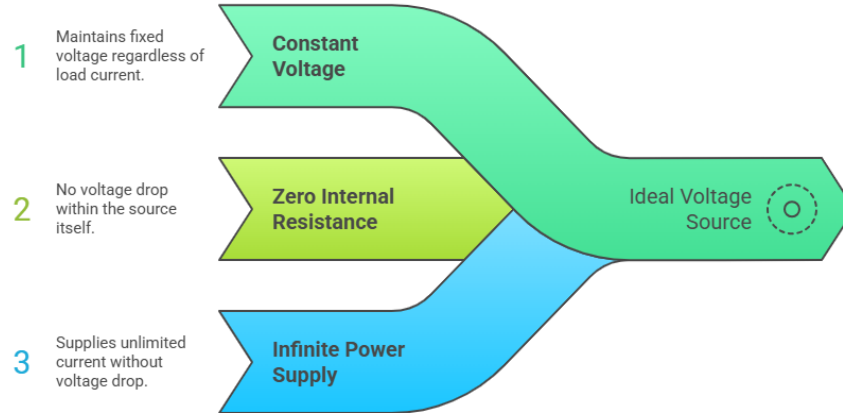

Made with  Napkin

Practical Voltage Source

consists of an ideal voltage source in series with an internal resistance (r).

Practical Voltage Source Structure

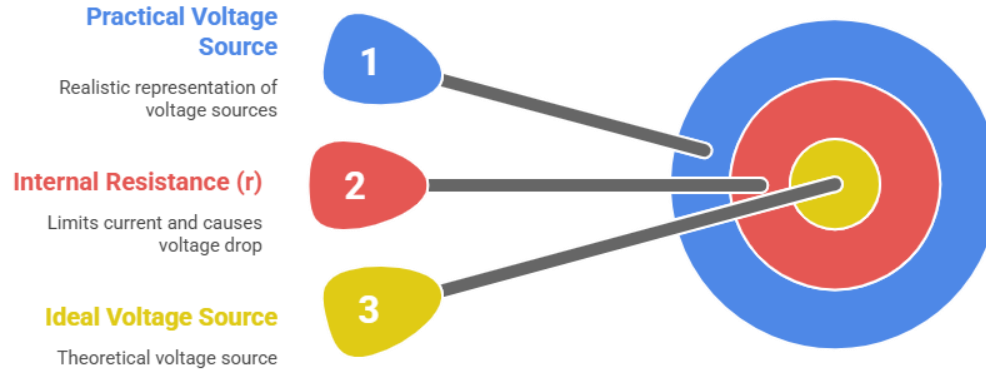

Made with  Napkin

Characteristics of a Practical Voltage Source:

- Voltage Drop
- Internal Resistance
- Finite Power Supply.

Characteristics of a Practical Voltage Source

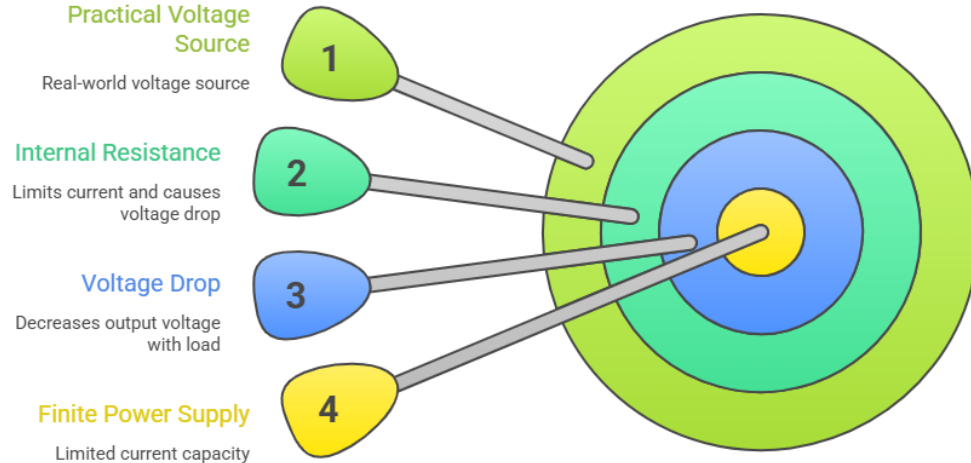

Made with  Napkin

Ideal Current Source

Provides a constant current, regardless of the voltage across its terminals.

Characteristics of an Ideal Current Source:

- **Constant Current**
- **Infinite Internal Resistance**
- **Infinite Voltage Supply**

Characteristics of an Ideal Current Source

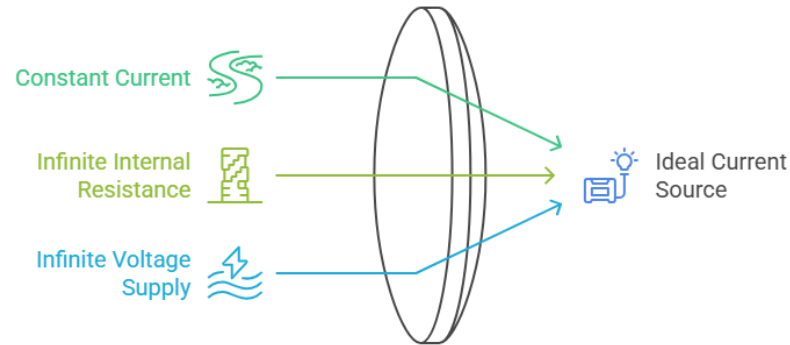

Made with  Napkin

Practical Current Source

Consists of an ideal current source in parallel with an internal resistance (R).

Characteristics of a Practical Current Source:

- **Current Deviation**
- **Internal Resistance**
- **Finite Voltage Supply**

Practical current source characteristics range from ideal to limited.

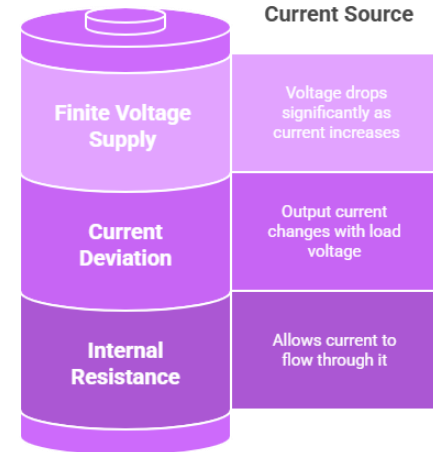

Made with  Napkin

Source transformation - Voltage Source to Current Source or Current Source to Voltage Source

An electrical source transformation is a method for simplifying circuits by replacing a voltage source with its equivalent current source, or vice versa.

Source transformation - Voltage Source to Current Source or Current Source to Voltage Source

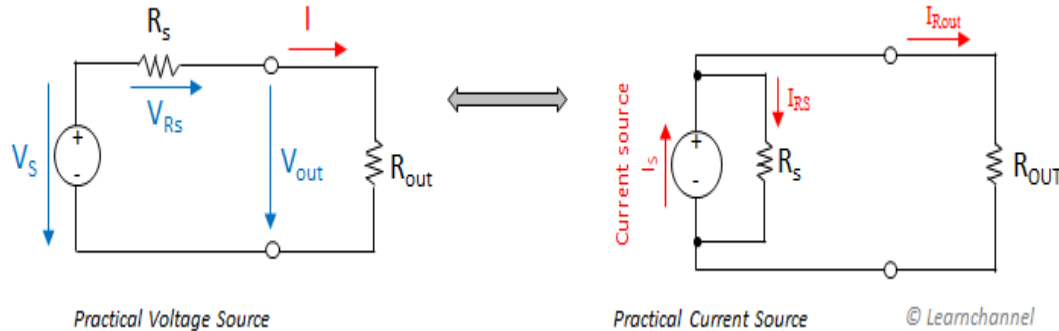

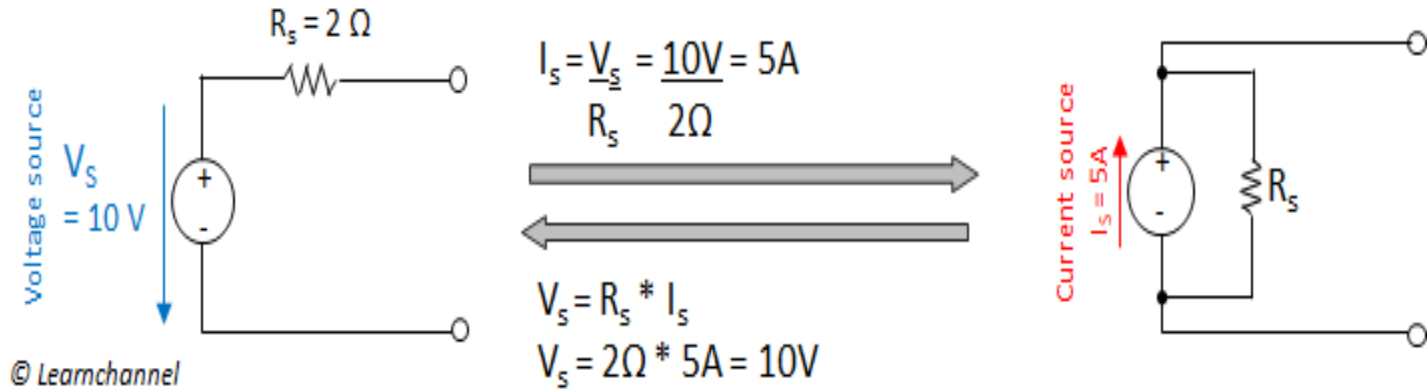

Example: Source transformation - Voltage Source to Current Source and vice versa

Source transformation example - Voltage Source to Current Source and vice versa

REFERENCES

- <https://www.geeksforgeeks.org/what-is-voltage-source/>
- <https://www.electricaltechnology.org/2022/11/difference-between-voltage-source-current-source.html>
- <https://vsa.edu.in/ideal-practical-voltage-sources/>
- <https://edurev.in/t/243523/Voltage-Sources>

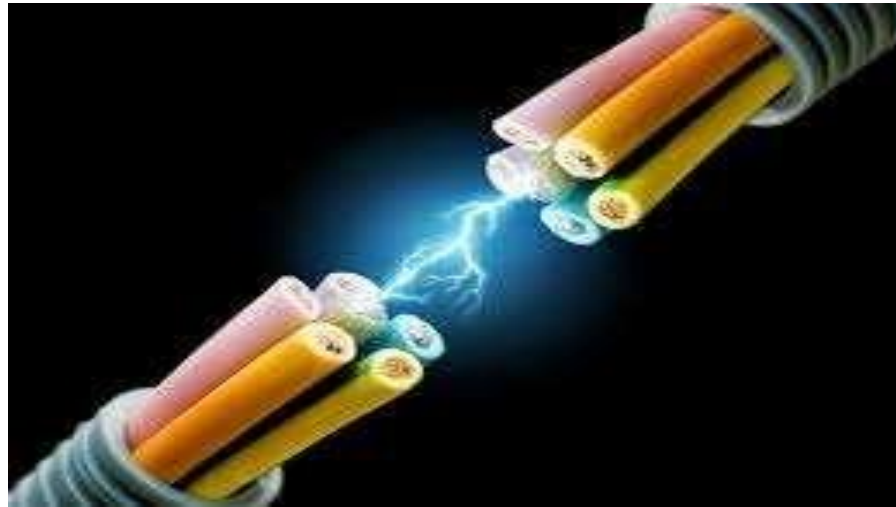

...THANK YOU