

## Department of Artificial Intelligence and Data Science

23EET103-Electric Circuits and Electronic Devices

I B.TECH CSE-IOT / II SEMESTER

UNIT IV : ELECTRONIC DEVICES AND APPLICATIONS

### Topic 1 : PN Junction Diode

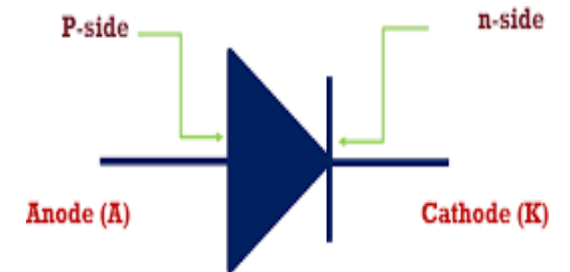

Symbol Of power Diode

# Let's Recall !!

- What is a semiconductor?
- What happens when P-type and N-type materials join?
- Can a diode conduct current in both directions?
- Why do we use diodes in rectifiers?

# Topics for discussion

- What is a Diode?
- Construction and operation of Diode
- Types of Bias conduction
- Characteristics and applications
- Role in real-world industries

# Let's Explore !!

- When P-type and N-type semiconductors join → **PN junction** is formed.
- Free electrons from N-side diffuse into P-side and recombine with holes.
- This creates a **depletion region** and **barrier potential**.
- Diode allows current flow **only in one direction**.

# PN Junction Diode

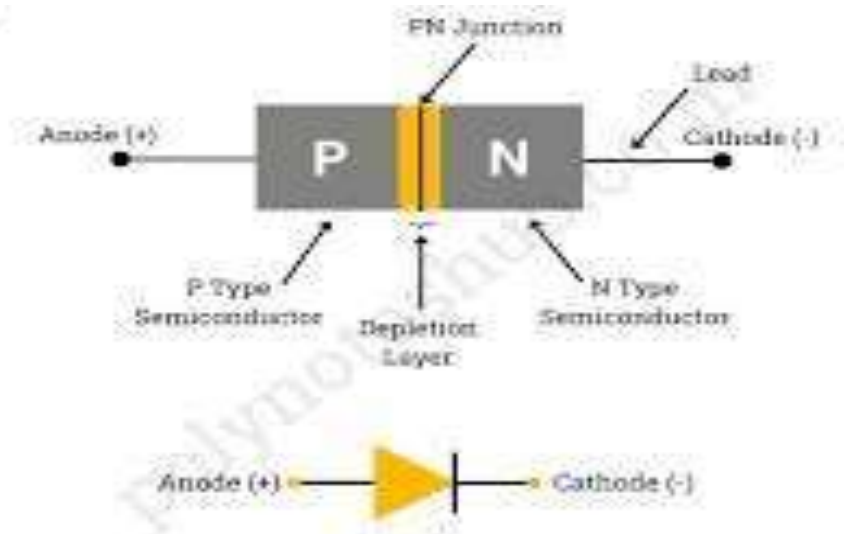
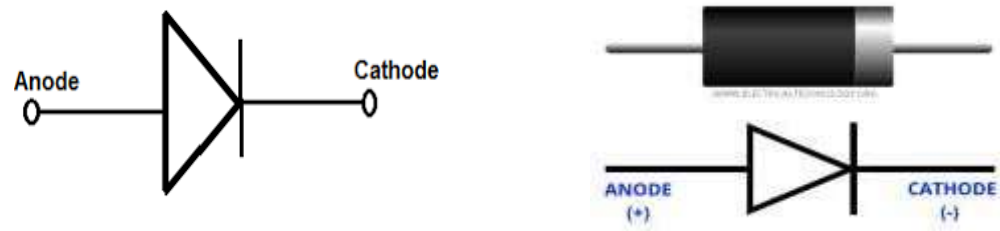

Construction of PN Junction Diode and Symbol

- A two-terminal semiconductor device.
- **Terminals: Anode (P-side) & Cathode (N-side).**
- Works on the principle of **unidirectional conduction.**

# Working of PN Diode

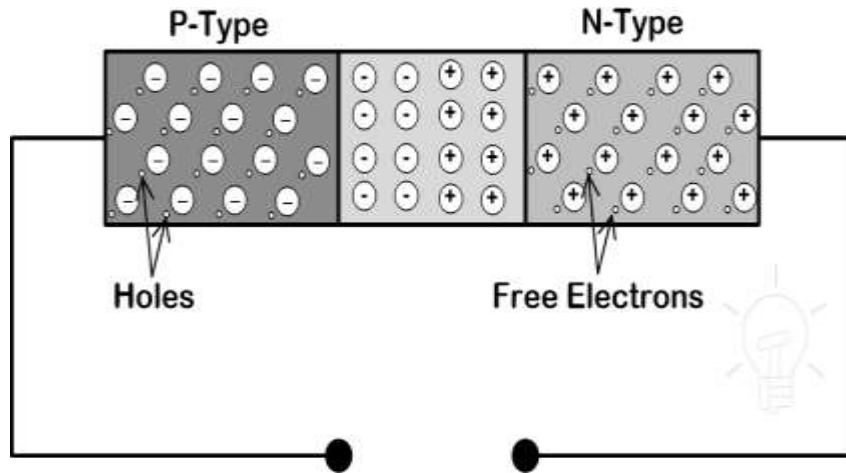

- In the N-type region, electrons are the majority charge carriers and holes are minority charge carriers.
- In the P-type region, the holes are majority charge carrier and the electrons are negative charge carriers.
- Because of the concentration difference, majority charge carriers diffuse and recombine with the opposite charge. It makes a positive or negative ion.
- These ions are collected at the junction. And this region is known as the depletion region.

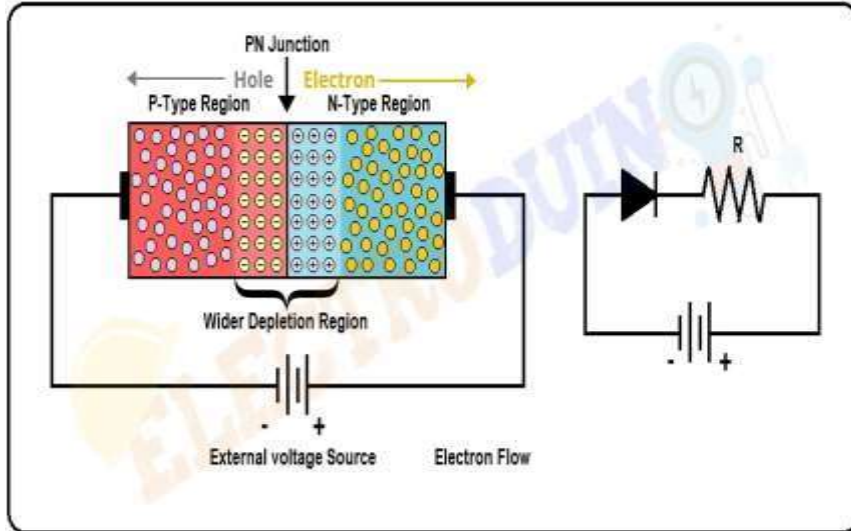

# Working of PN Diode

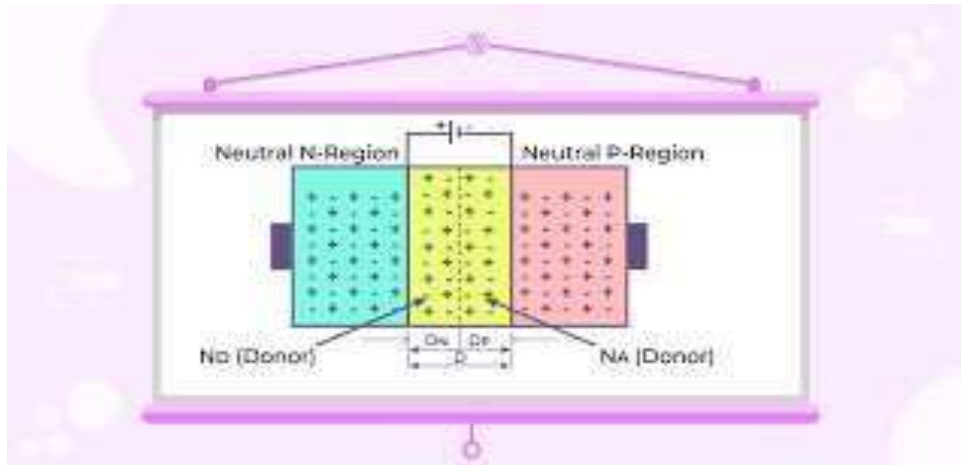

When anode terminal of diode is connected with a negative terminal and cathode is connected with the positive terminal of a battery, the diode is said to be connected in reverse bias.

Similarly, when anode terminal is connected with a positive terminal and cathode is connected with the negative terminal of the battery, the diode is said to be connected in forward bias.

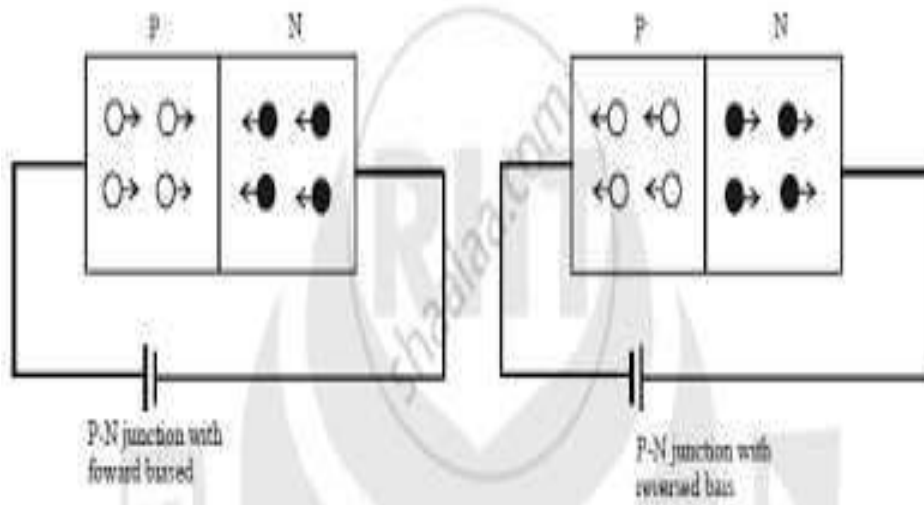

# Forward Bias Condition

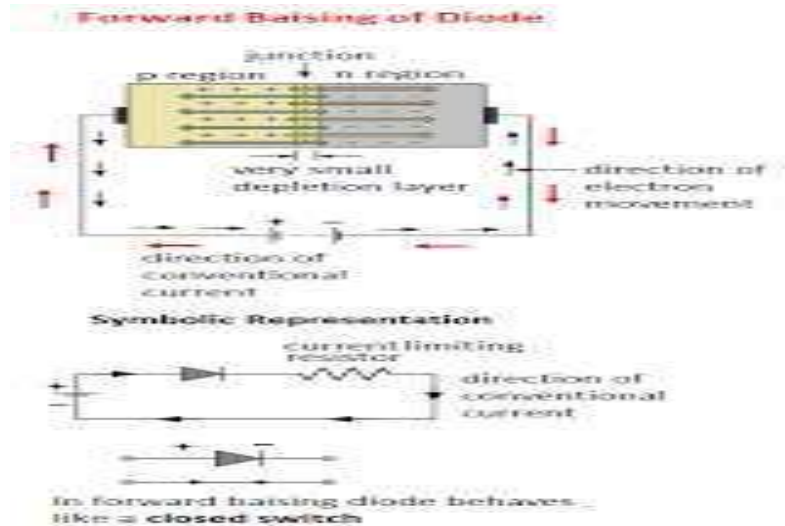

- When the anode is connected with the positive terminal of the battery and cathode is connected with a negative terminal of the battery, the anode is positive with respect to the cathode and the diode is said to be connected in forward bias.
- Now, we gradually increase the supply voltage. If we increase a small voltage, the majority charge carrier does not get sufficient energy to cross the depletion region.
- In the forward bias conditions, the width of the depletion region is very small.

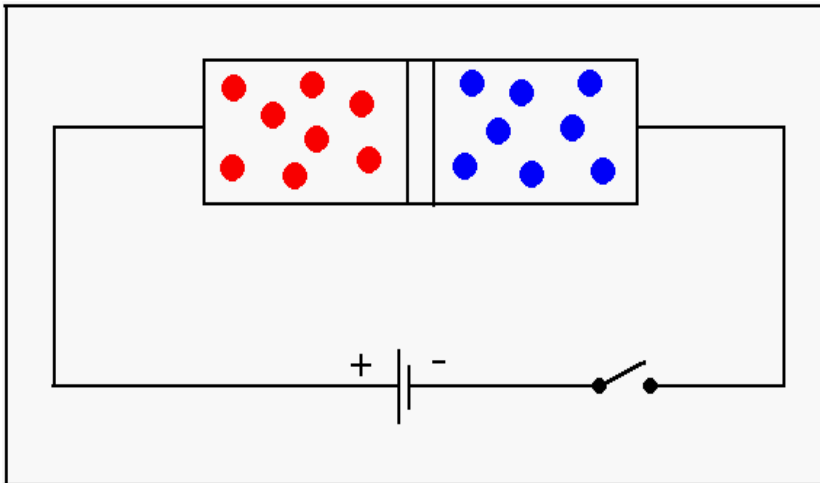

# Forward Bias Condition

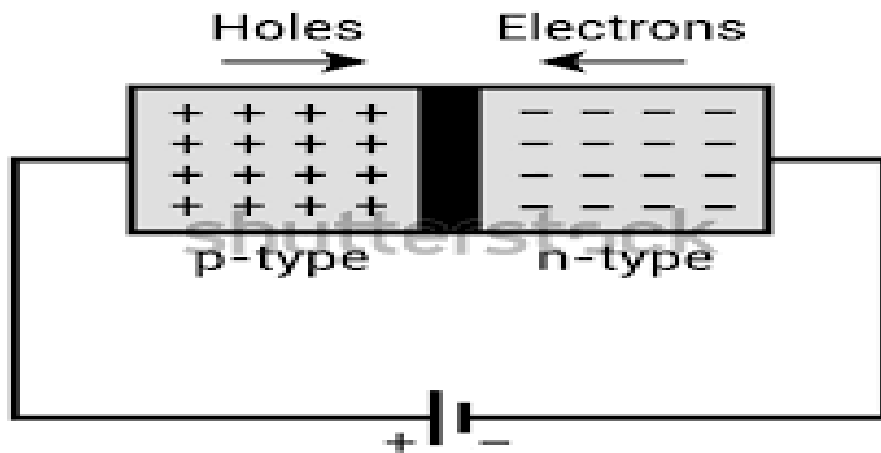
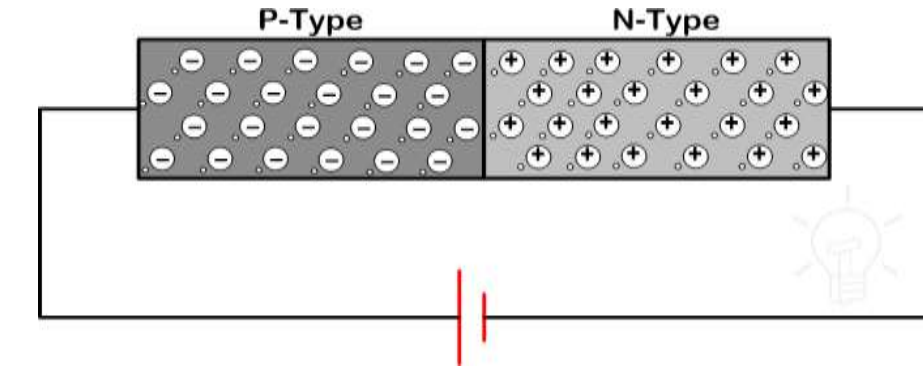

www.shutterstock.com - 5135387979

- If we increase the voltage more than forward breakover voltage, the majority charge carrier gets enough energy to cross the depletion region.
- For silicon forward breakover voltage is 0.7V and for germanium forward breakover voltage is 0.3V.
- When supply voltage increases more than this voltage, the majority charge carriers flowing through the circuit and it made the diode conducting.
- In this mode of operation, a very small amount of drop occurs. This drop is known as an on-state voltage drop. The connection diagram of this mode

# Reverse Bias Condition

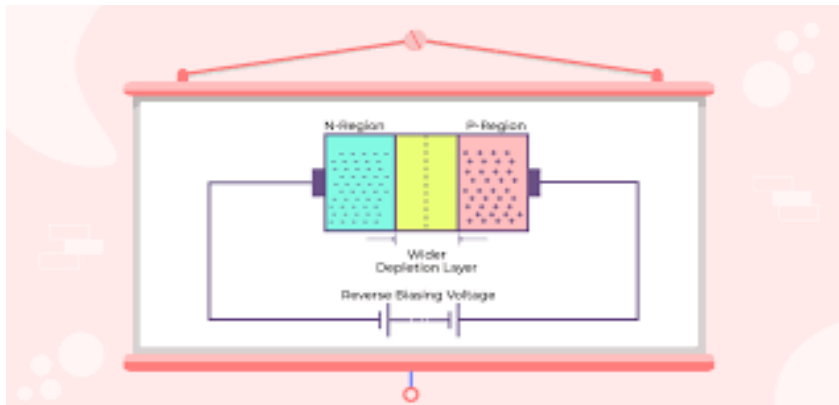
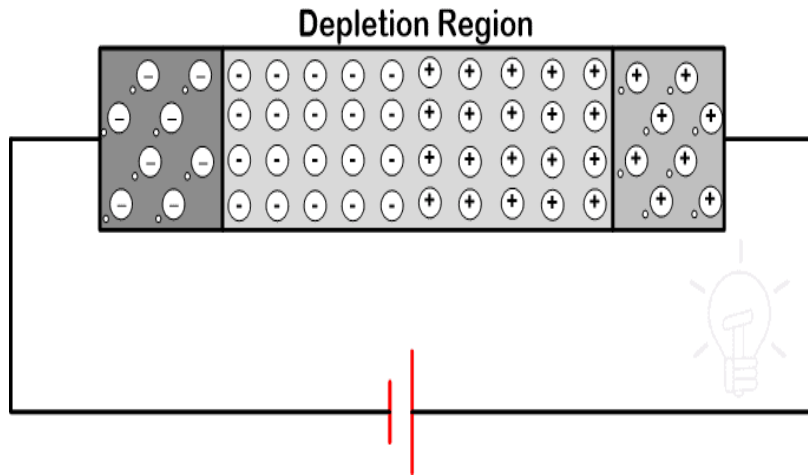

- The diode is connected in reverse bias. In this condition, free electrons diffusing into the P-type regions and recombine with holes.
- It will create negative ions. Similarly, holes diffuse into the N-type region and recombine with electrons. It will create positive ions.
- When such voltage is applied to the circuit, immobile ions create a depletion region as shown in the above figure. The width of the depletion region is large. Hence, no more hole or electron crosses the junction.
- It cannot create a flow of electrons or holes even if it is supplied at rated voltage. Hence, it is not possible to flow the current through the diode and it behaves as an open switch.

# Reverse Bias Condition

Depletion Region

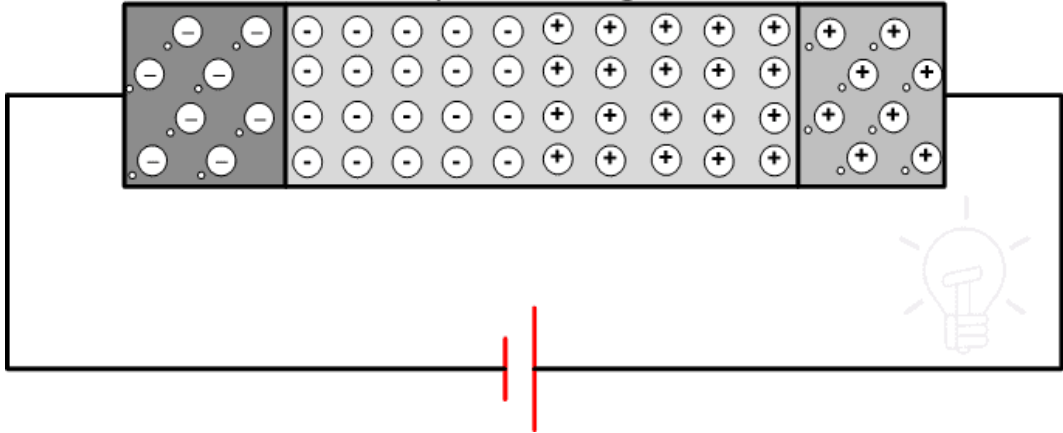

- Here a very small amount of current will flow through the circuit. This current is known as reverse saturation current or reverse leakage current.
- This current flow due to the minority charge carriers. This current is not high enough to conduct the diode.
- If we increase the voltage up to reverse breakover voltage, the minority charge carriers get high kinetic energy and collide with atoms.
- In this condition, the number of covalent bonds broken and a huge number of electrons-holes pair generates a huge amount of flow of current.

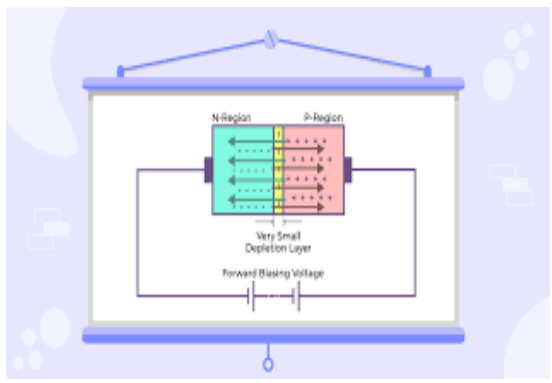
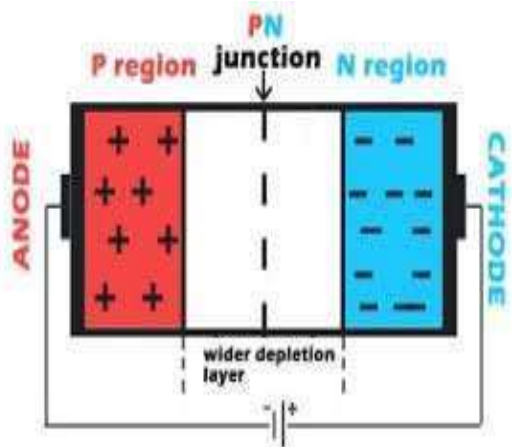

# PN Diode

*DT-Define*

Type

Applications

PN Diode

Rectification

Zener Diode

Voltage regulation

LED

Lighting, indicators

Schottky Diode

High-speed switching

Photodiode

Sensors, communication

# Real-World Applications of PN Diode

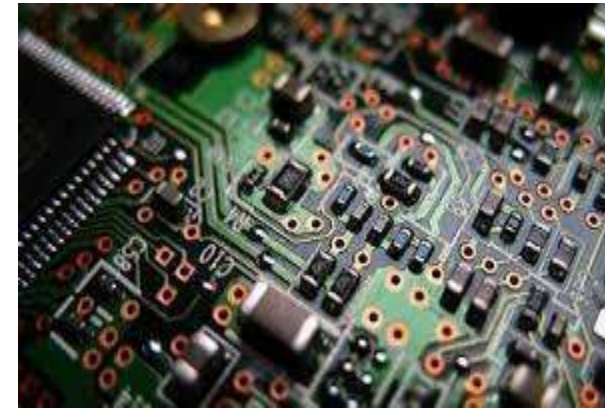
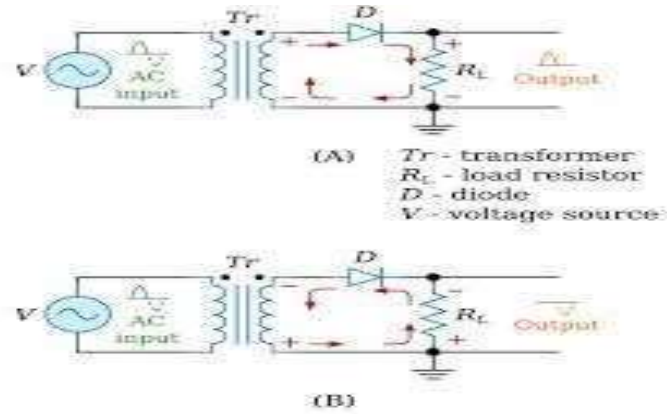

# Let's summarize

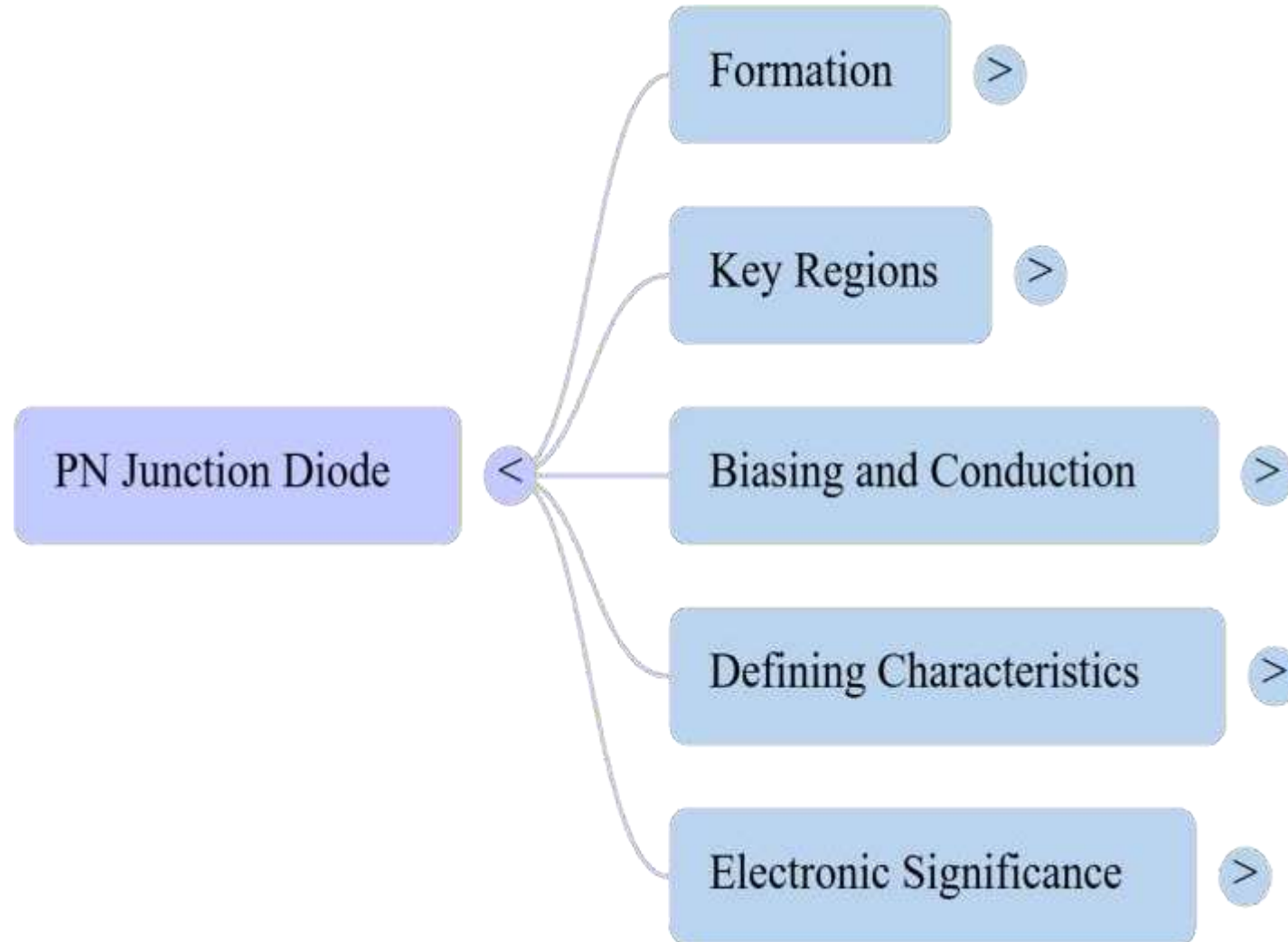

# References

- “Electronic Devices & Circuits” – Boylestad & Nashelsky
- “Integrated Electronics” – Millman & Halkias
- [www.electronics-tutorials.ws](http://www.electronics-tutorials.ws)
- [www.electrical4u.com](http://www.electrical4u.com)
- [www.learnabout-electronics.org](http://www.learnabout-electronics.org)

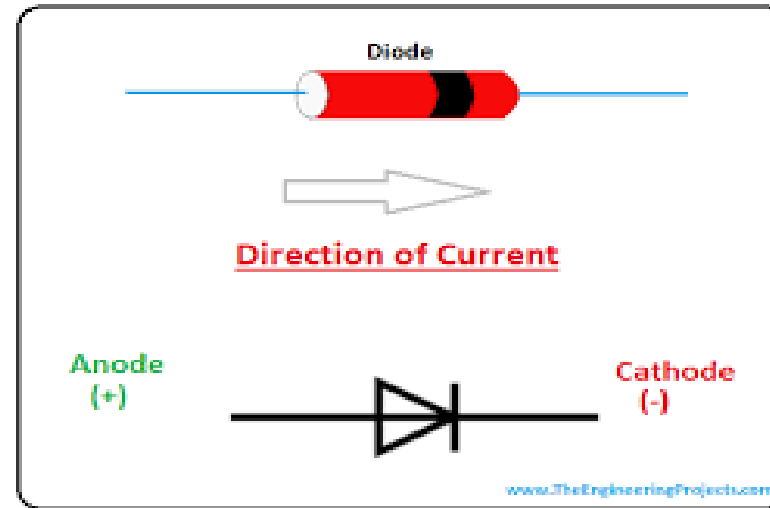

THANK  
YOU