



SNS COLLEGE OF ENGINEERING

Kurumbapalayam (Po), Coimbatore – 641 107

An Autonomous Institution

Accredited by NBA – AICTE and Accredited by NAAC – UGC with 'A' Grade

Approved by AICTE, New Delhi & Affiliated to Anna University, Chennai

DEPARTMENT OF ELECTRICAL AND ELECTRONICS ENGINEERING

COURSE NAME : 19EE101 BASIC ELECTRICAL AND ELECTRONICS ENGINEERING

I YEAR /I SEMESTER MECHANICAL ENGINEERING

Unit 1 – Electrical Circuits and Measurements

Principle of Moving coil instruments

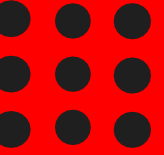



MEASURING INSTRUMENTS

I have two electrical supply as Alternating current and Direct current. Can I use same instrument for measuring the two supply?





TYPES OF MOVING COIL INSTRUMENTS

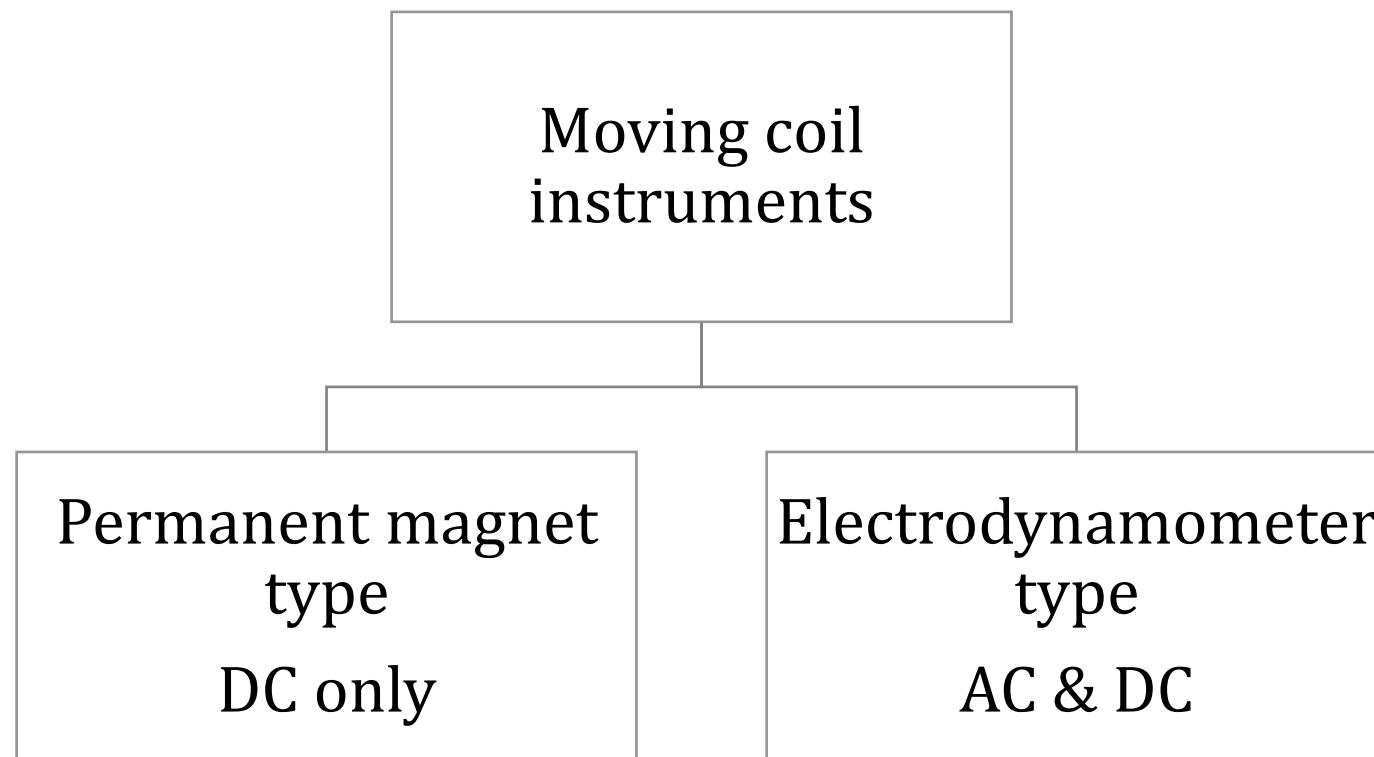
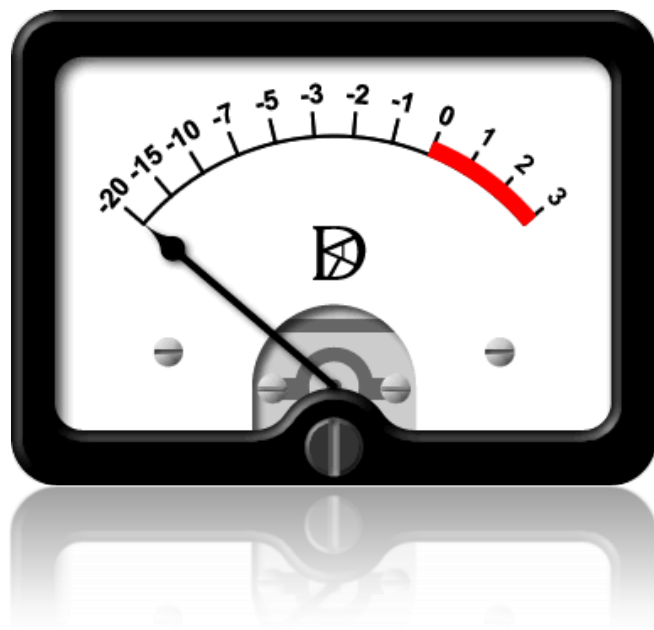

PMMC Instruments

Principle

“when a current-carrying conductor is placed in a magnetic field, it is acted upon by a force which tends to move it to one side and out of the field”.

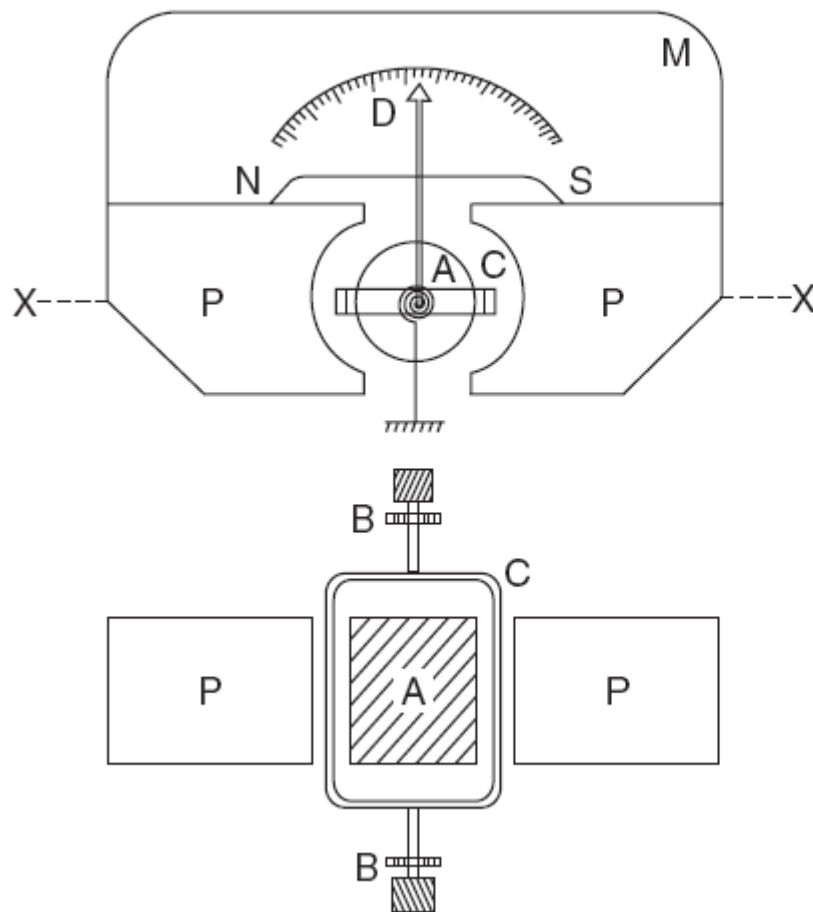

- M = Permanent magnet
- PP = Soft iron pole pieces
- A = Soft iron cylinder
(central core)
- C = Rectangular coil
- B = Spiral springs
- D = pointer



Deflecting torque.

$$F = BI l \text{ newton}$$

- B = flux density in WB/m^2 , and
- l = length or depth of coil in metres.

Deflecting torque (T_d)

= force \times perpendicular distance

$$= NBIl \times b = NBI (l \times b) = NBI A \text{ Nm}$$

Controlling torque (T_c) = deflecting torque (T_d)

$$\text{Hence } c\theta = kI$$

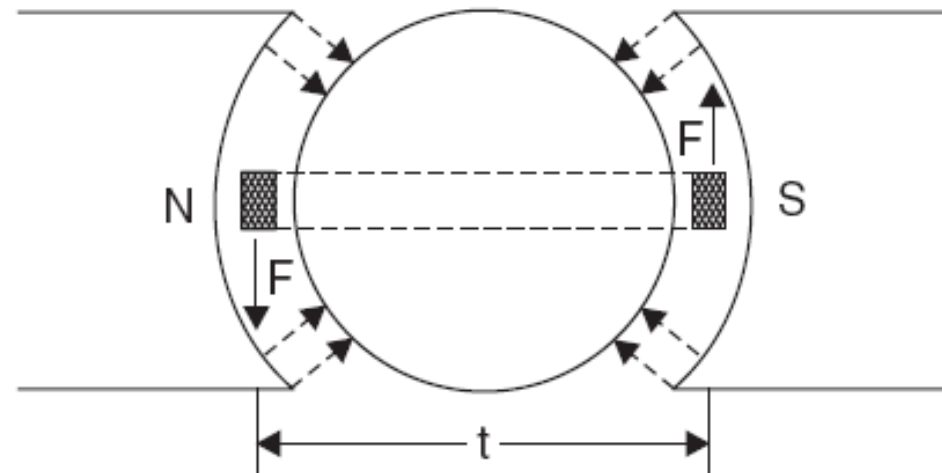



COMPARISON

ADVANTAGES

- (i) Low power consumption.
- (ii) Their scales are uniform.
- (iii) No hysteresis loss.

DISADVANTAGES

- (i) Somewhat costlier as compared to moving-iron instruments.
- (ii) Cannot be used for A.C. measurements.
- (iii) Friction and temperature might introduce errors as in case of other instruments.

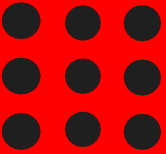



ASSESSMENT 1

1. when a current-carrying conductor is placed in a _____, it is acted upon by a force which tends to move it to one side and out of the field”.

2. Mention the advantages and disadvantages of PMMC coil instrument

S.No	Advantages	Dis-advantages

Dynamometer Instruments

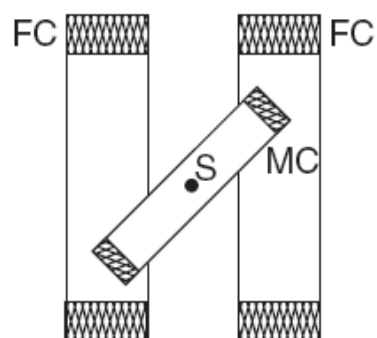
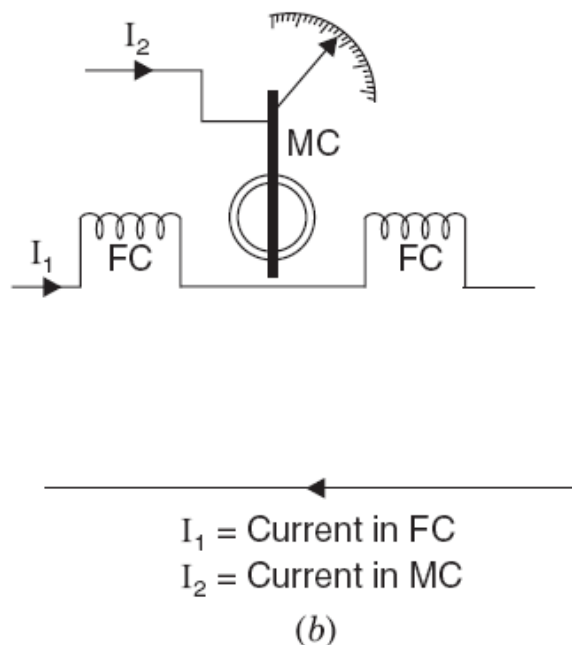
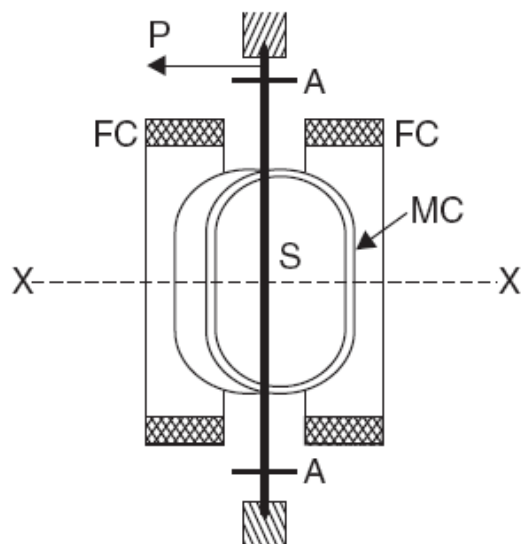

FC = Field coils (divided into two halves)
 MC = Moving coils
 S = Spindle
 A = Spiral hair springs

In an electro-dynamic instrument the operating field is produced by another fixed coil and not by permanent magnet.



MAGNETIC FIELDS

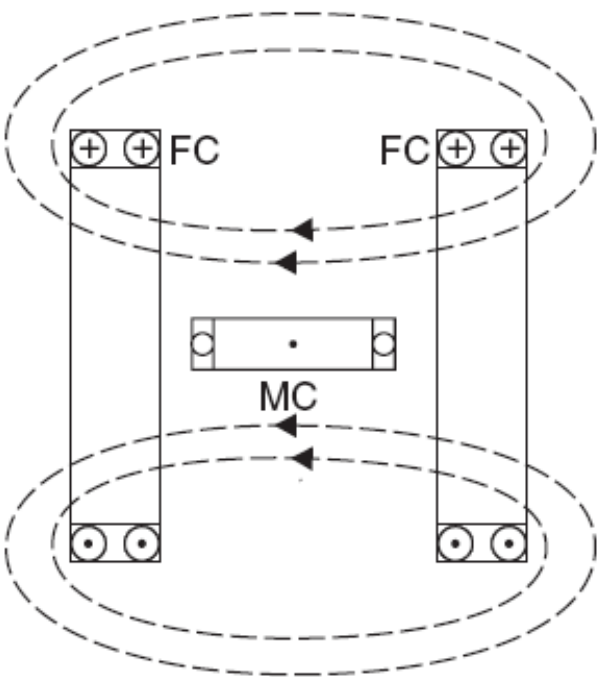
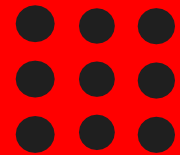

(a)

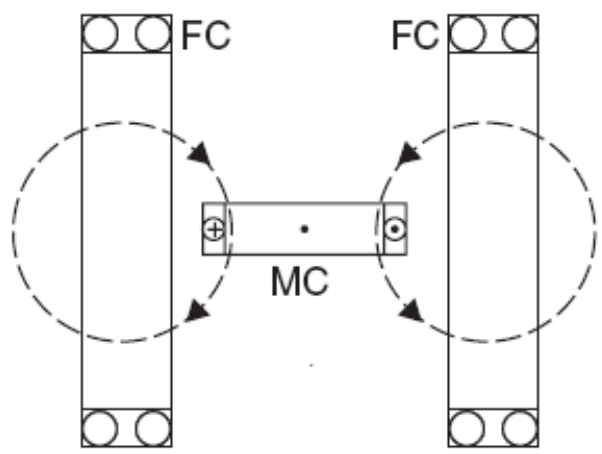

(b)

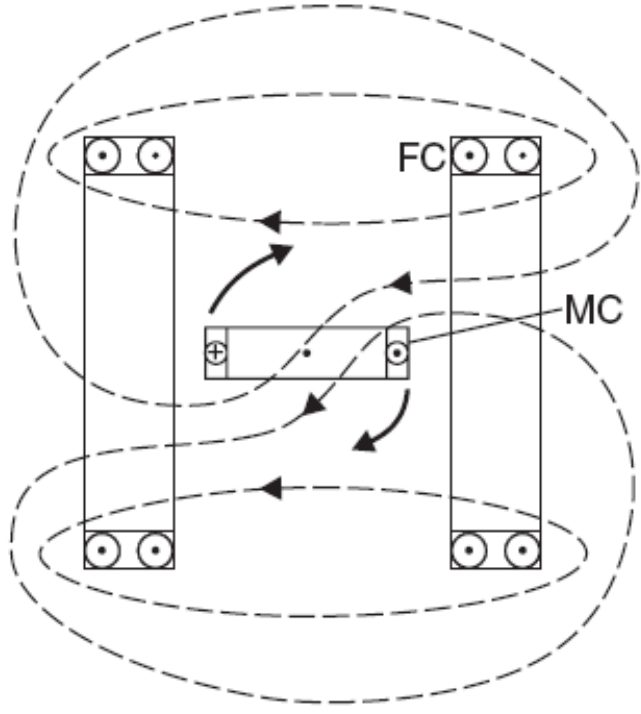

(c)





COMPARISON OF DYNAMOMETER TYPE

Advantages :

- Can be used on both D.C. as well as A.C. systems.
- They are free from hysteresis and eddy current errors.

Disadvantages :

- Since torque/weight ratio is small, such instruments have low sensitivity.
- The scale is not uniform because $\theta \propto I$.
- Cost of these instruments is higher in comparison to those of moving iron instruments.



Assessment 2

1. List down the parts of Dynamometer type moving coil instrument.

- _____
- _____
- _____

2. List the Advantages and Dis-advantages of Dynamometer type moving coil instrument.

S.No	Advantages	Dis-advantages



REFERENCES

1. Bhattacharya. S.K, “Basic Electrical and Electronics Engineering”, Pearson Education , (2017)
2. Muthu Subramanian R, Salivahanan S,“ Basic Electrical and Electronics Engineering”, Tata McGraw Hill Publishers, (2009)
3. V.Mittle“ Basic Electrical Engineering”, Tata McGraw Hill Publishers, (2017)
4. Nagrath. I.J, “Electronics: Analog and Digital”, Prentice Hall India Pvt. Ltd., (2013)

THANK YOU