

DIFFERENCE BETWEEN TRANSDUCER AND SENSOR



TRANSDUCER

A TRANSDUCER IS A DEVICE THAT CONVERTS ENERGY FROM ONE FORM TO ANOTHER. USUALLY A TRANSDUCER CONVERTS A SIGNAL IN ONE FORM OF ENERGY TO A SIGNAL IN ANOTHER.



SENSOR

SENSOR IS A DEVICE, MODULE, OR SUBSYSTEM WHOSE PURPOSE IS TO DETECT EVENTS OR CHANGES IN ITS ENVIRONMENT AND SEND THE INFORMATION TO OTHER ELECTRONICS, FREQUENTLY A COMPUTER PROCESSOR.

DIFFERENCE BETWEEN SENSOR AND TRANSDUCER



Sensor

Device that detects the physical changes from the nearby environment into easy to read format for the user.

VS



Transducer

Device that converts the energy from one form to another. Usually it converts energy into electrical signal and vice versa.

Basis For Comparison	Sensor	Transducer
Definition	Senses the physical changes occurs in the surrounding and converting it into a readable quantity.	The transducer is a device which, when actuates transforms the energy from one form to another.
Components	Sensor itself	Sensor and signal conditioning
Function	Detects the changes and induces the corresponding electrical signals.	Conversion of one form of energy into another.
Examples	Proximity sensor, Magnetic sensor, Accelerometer sensor, Light sensor, Barometer, Gyroscope etc.	Thermistor, Potentiometer, Thermocouple, etc.

TRANSDUCER

A device that converts variations in a physical quantity, such as pressure or brightness, into an electrical signal, or vice versa.

A transducer is **an electronic device that converts energy from one form to another**. The process of converting energy from one form to another is known as transduction.

Ex: of transducers include loudspeakers, microphones, thermometers and LEDs.

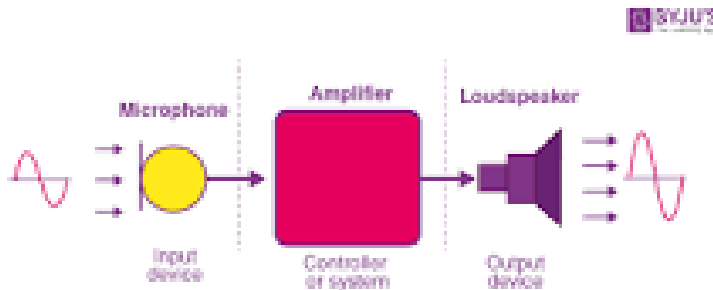

What is a Linear Transducer?

Linear transducers measure linear displacement or movement along a single axis in any direction. They do this by converting the movement into an electrical signal which is proportional to the displacement so that it can be processed by various devices.

Linear Transducers are available in different types, each type is better suited to a different application or environment. Some linear transducers have different certifications making them well suited to hazardous areas or intrinsically safe applications. They are also available in various sizes to suit long-range applications or applications where space is restricted.

Types of Linear Transducer

The different types of linear transducers we have available are;

Potentiometer – we offer our range of potentiometers which are a type of linear transducer. They use an internal resistive track and wipers to monitor the position of an object.

LVDT – another non-contact type of linear transducer,

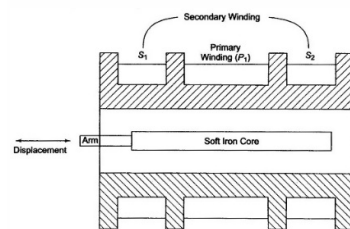

Fig. 13.19 Construction of a Linear Variable Differential Transducer (LVDT)

LVDT is an acronym for **Linear Variable Differential Transformer**. It is a common type of electromechanical transducer that can convert the rectilinear motion of an object to which it is coupled mechanically into a corresponding electrical signal.

Cable Extension Transducer – an alternative solution for linear displacement, a cable extension transducer uses a flexible cable. These have a greater stroke-to-length ratio making them well suited to long-range applications.

Other Types of Transducer

At Variiohm we have a selection of various transducers for different types of measurement. Some of these include;

Pressure Transducers – for accurate measurement of actual pressure

Temperature Transducer – for temperature measurement

Rotary position transducers – to measure position in a rotary fashion

Linear Transducer Applications

Linear transducers are very popular devices and are used throughout many industries. Some of these include;

- Motorsport applications
- Industrial applications
- Agricultural vehicles
- HVAC
- Hazardous area applications
- Automotive applications
- Robotics
- Medical applications

Rotary transducers

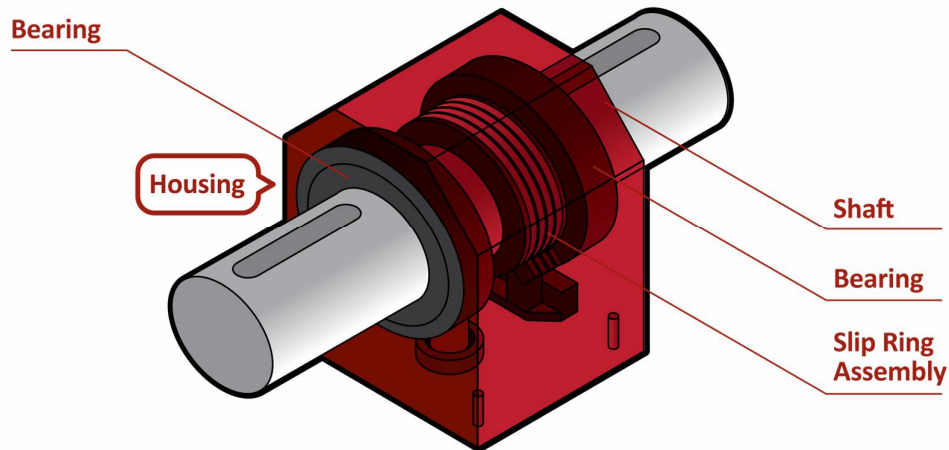

What are rotary transducers?

A rotary torque transducer is a **device used for measuring the torque on a rotating system such as the tightening torque applied by continuous and impulse power tools**. Torque transducers are a small but incredibly vital piece of kit for a whole host of industries.

How do Rotary transducers work?

A rotary torque meter or torque transducer **measures torque in a rotating shaft**. Our rotary transducers sense torque with high-precision strain gages. Mounted on or embedded in the rotating element, these respond to shear forces with changing electrical resistance.

Is a transducer an encoder?

Encoder - applications

Encoder and rotary transducers measure the rotation angle and usually provide digital output signals which are decoded by an evaluation unit. Therefore, **the encoder is also called rotary transducer**.