



SNS COLLEGE OF ENGINEERING



Kurumbapalayam(Po), Coimbatore - 641 107

Accredited by NAAC-UGC with 'A' Grade

Approved by AICTE, Recognized by UGC & Affiliated to Anna University, Chennai

Department of Information Technology

Course Name - 19IT503 Internet of Things

III Year / V Semester

**Unit 5 - DESIGN METHODOLOGY AND FUTURE
TRENDS**

Topic - IoT Physical Devices & Endpoints

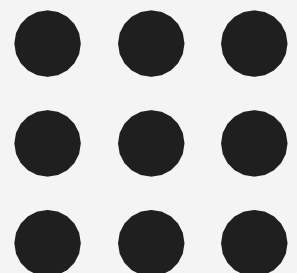



IoT Physical Devices & Endpoints

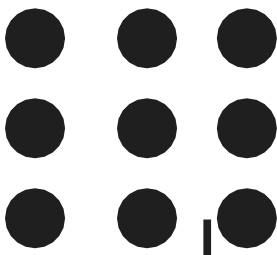

- Basic building blocks of an IoT Device
- Exemplary Device: Raspberry Pi
- Raspberry Pi interfaces
- Other IoT devices



IoT Physical Devices & Endpoints



IoT Device Examples

- A home automation device that allows remotely monitoring the status of appliances and controlling the appliances.
- An industrial machine which sends information about its operation and health monitoring data to a server.
- A car which sends information about its location to a cloud-based service.
- A wireless-enabled wearable device that measures data about a person such as the number of steps walked and sends the data to a cloud-based service.



IoT Physical Devices & Endpoints



Basic building blocks of an IoT Device

- Sensing : Sensors can be either on-board the IoT device or attached to the device.
- Actuation : IoT devices can have various types of actuators attached that allow taking actions upon the physical entities in the vicinity of the device.
- Communication : Communication modules are responsible for sending collected data to other devices or cloud-based servers/storage and receiving data from other devices and commands from remote applications.
- Analysis & Processing : Analysis and processing modules are responsible for making sense of the collected data.

IoT Physical Devices & Endpoints

Block diagram of an IoT Device

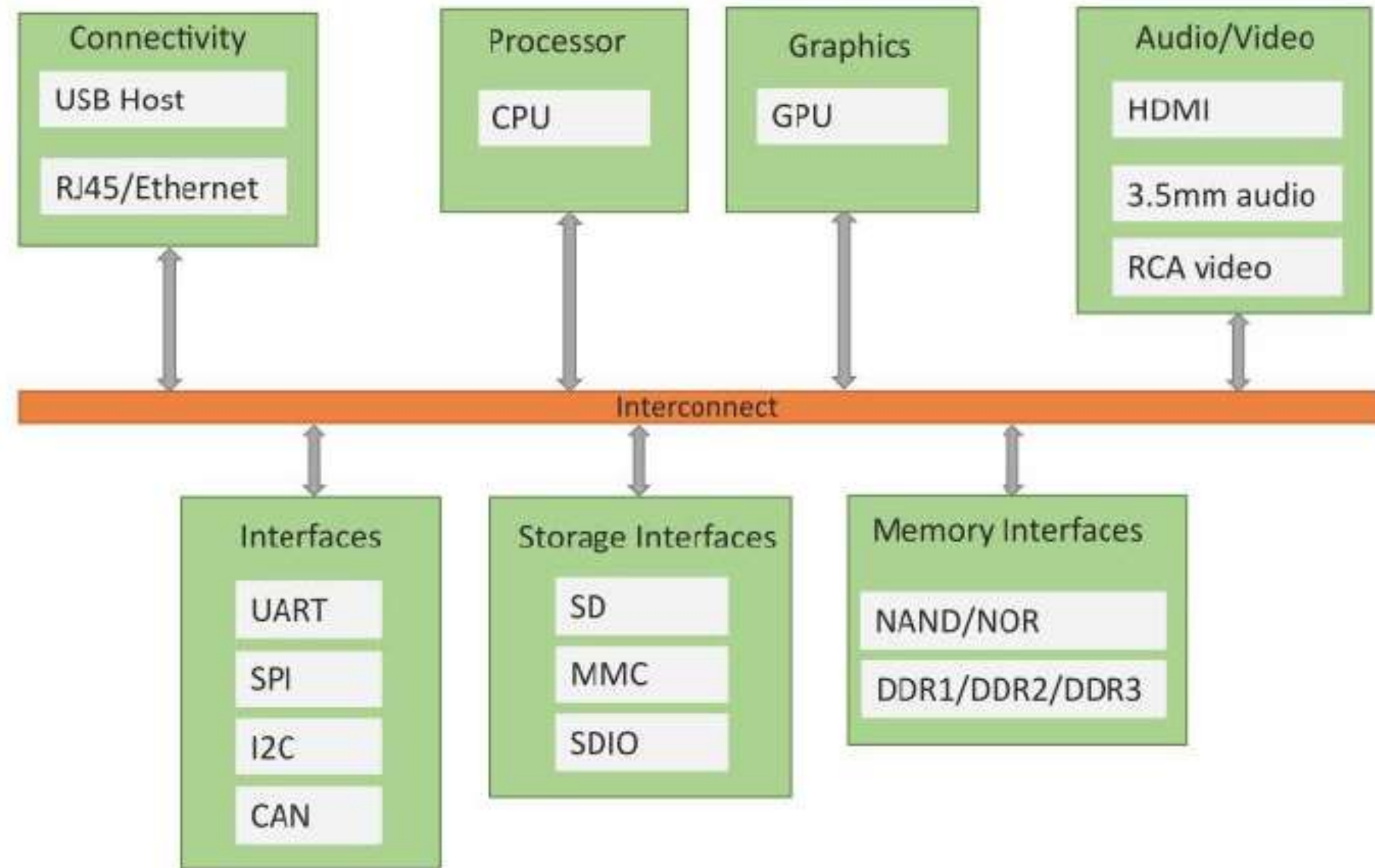

IoT Physical Devices & Endpoints

Exemplary Device: Raspberry Pi

- Raspberry Pi is a low-cost mini-computer with the physical size of a credit card.
- Raspberry Pi runs various flavors of Linux and can perform almost all tasks that a normal desktop computer can do.
- Raspberry Pi also allows interfacing sensors and actuators through the general purpose I/O pins.
- Since Raspberry Pi runs Linux operating system, it supports Python "out of the box".

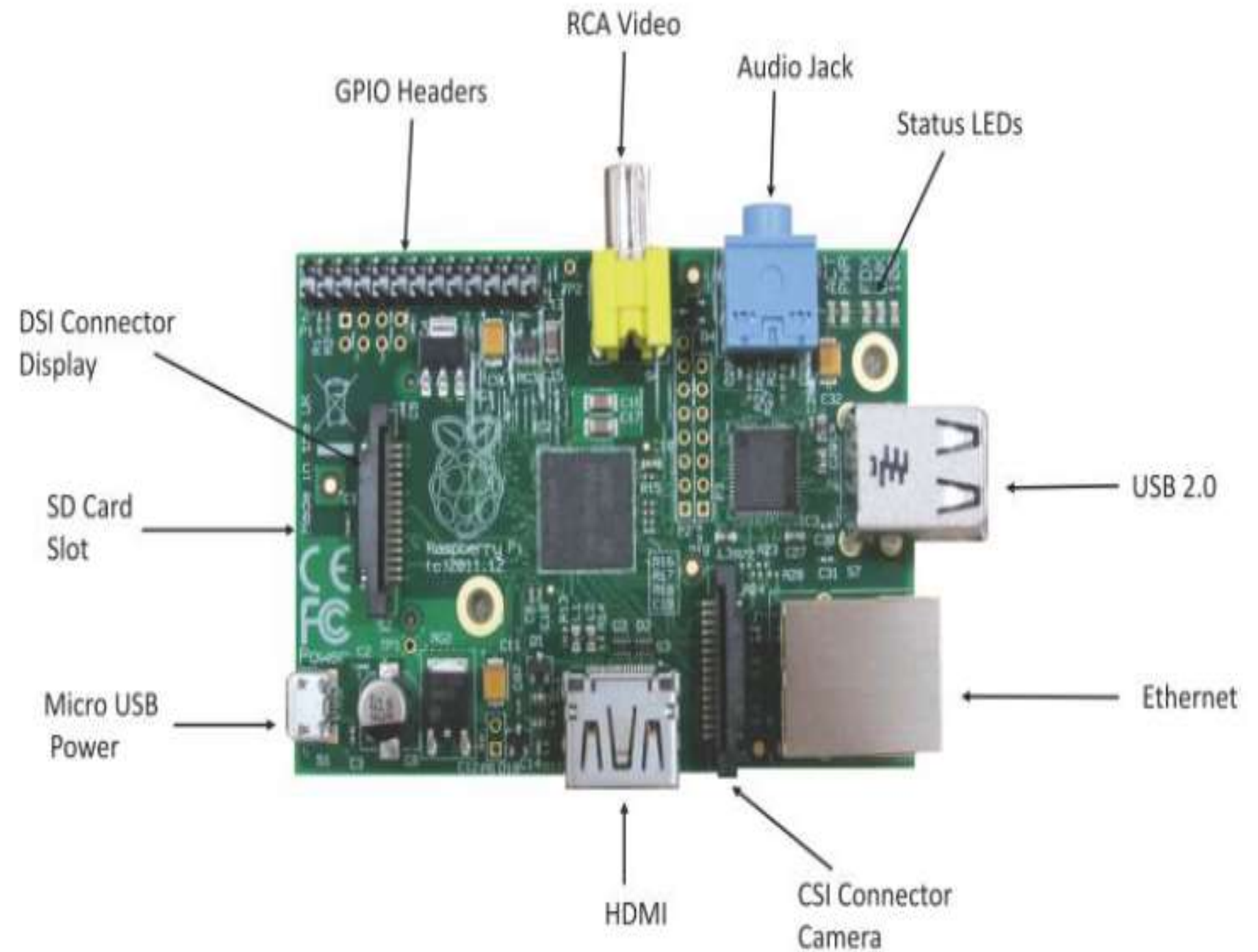



IoT Physical Devices & Endpoints



Linux on Raspberry Pi

- Raspbian
- Raspbian Linux is a Debian Wheezy port optimized for Raspberry Pi.
- Arch
- Arch is an Arch Linux port for AMD devices.
- Pidora
- Pidora Linux is a Fedora Linux optimized for Raspberry Pi.
- RaspBMC
- RaspBMC is an XBMC media-center distribution for Raspberry Pi.
- OpenELEC
- OpenELEC is a fast and user-friendly XBMC media-center distribution.
- RISC OS
- RISC OS is a very fast and compact operating system.

IoT Physical Devices & Endpoints

Raspberry Pi GPIO

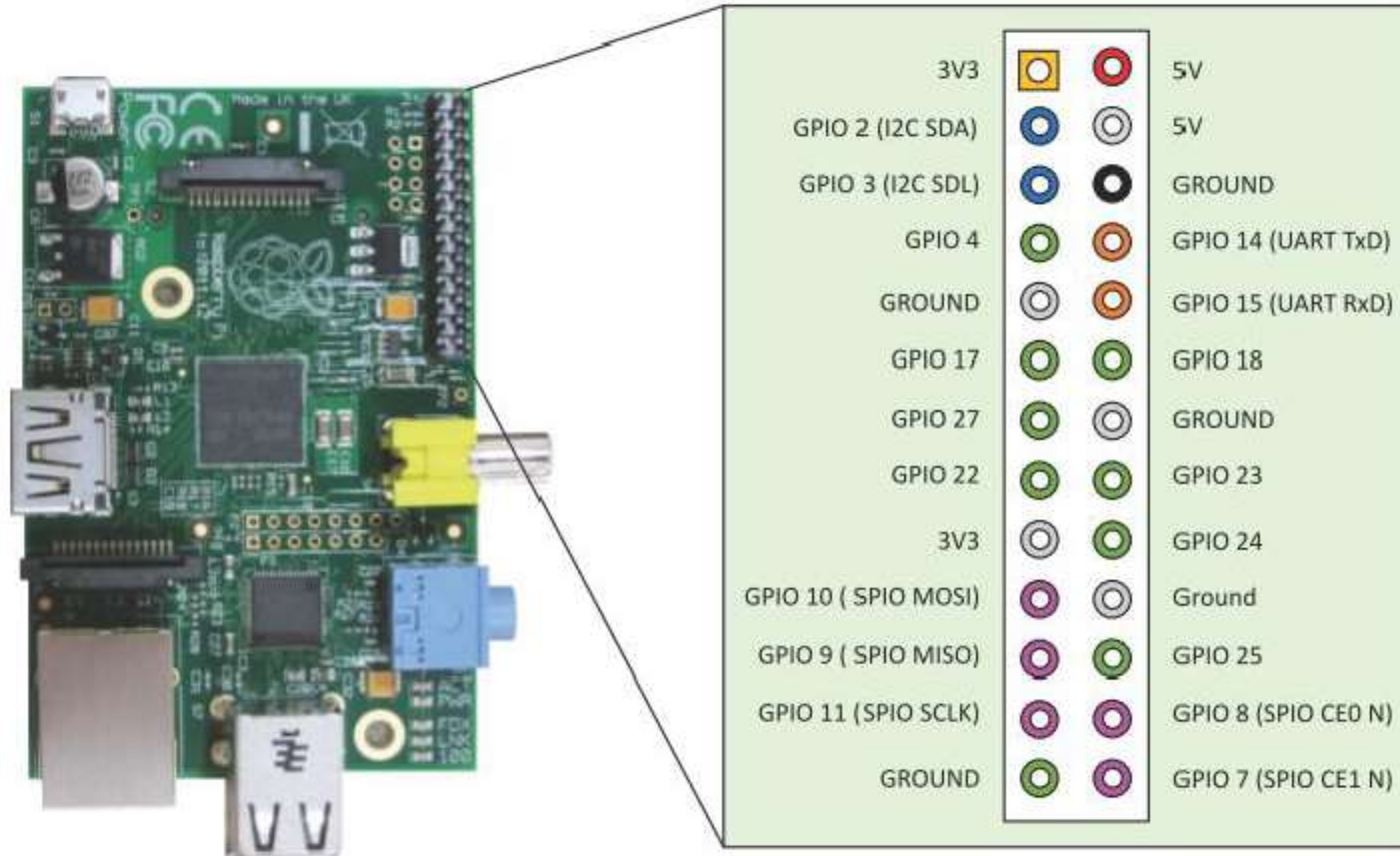



IoT Physical Devices & Endpoints



Raspberry Pi Interfaces

- Serial : The serial interface on Raspberry Pi has receive (Rx) and transmit (Tx) pins for communication with serial peripherals.
- SPI : Serial Peripheral Interface (SPI) is a synchronous serial data protocol used for communicating with one or more peripheral devices.
- I2C : The I2C interface pins on Raspberry Pi allow you to connect hardware modules. I2C interface allows synchronous data transfer with just two pins - SDA (data line) and SCL (clock line).

IoT Physical Devices & Endpoints

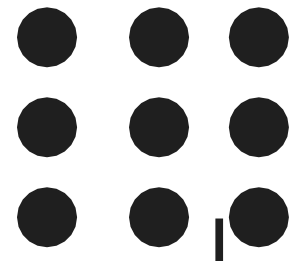

Other Devices

- pcDuino
- BeagleBone Black
- Cubieboard

BeagleBone Black



pcDuino



Cubieboard



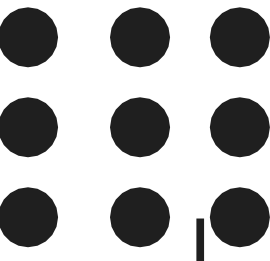

IoT Physical Devices & Endpoints

pcDuino

- It is Arduino-pin compatible single board mini computer that comes with a 1 GHz ARM Cortex A8 Processor.
- pcDunio is a high performance and cost effective device that runs PC like OS such as Ubuntu and Android ICS.
- It supports various programming languages like C,C++, Java and Python.

BeagleBone Black

- It is similar to Raspberry pi but more powerful device. It comes with 1 GHz ARM Cortex A8 Processor that supports Linux and Android OS.
- It has HDMI video/audio interface, USB and Ethernet Ports

Cubieboard

It is powered by dual core ARM Cortex A7 Processor and has USB, HDMI, IR, Serial, Ethernet, SATA and 96 pin extended interface. IT supports Linux and Android OS.