

**UNIT 1**

**1. What are the three criteria necessary for an effective and efficient network?**

The most important criteria are performance, reliability and security. Performance of the network depends on number of users, type of transmission medium, the capabilities of the connected h/w and the efficiency of the s/w. Reliability is measured by frequency of failure, the time it takes a link to recover from the failure and the network's robustness in a catastrophe. Security issues include protecting data from unauthorized access and viruses.

**2. Group the OSI layers by function.**

The seven layers of the OSI model belonging to three subgroups. Network support layers: Consisting of Physical, data link and network layers and they deal with the physical aspects of moving data from one device to another. User support layers: Consists of Session, presentation and application layers and they allow interoperability among unrelated software systems. The transport layer ensures end-to-end reliable data transmission

**3. What are the features provided by layering?**

- It decomposes the problem of building a network into more manageable components. Rather than implementing a monolithic piece of software that does everything implement several layers, each of which solves one part of the problem.
- It provides more modular design. To add some new service, it is enough to modify the functionality at one layer, reusing the functions provided at all the other layers.

**4. What are the two interfaces provided by protocols?**

- Service interface
- Peer interface
- Service interface-defines the operations that local objects can perform on the protocol.
- Peer interface-defines the form and meaning of messages exchanged between protocol peers to implement the communication service.

**5. What is LAN?**

A LAN is a common name used to describe a group of devices that share a geographic location. LAN is limited to single building or campus.

**6. What is flow Control?**

Flow control refers to a set of procedures used to restrict the amount of data. The sender can send before waiting for acknowledgment.

**7. Define Error detection and correction.**

Error Detection:

Data can be corrupted during transmission. It is called as an error. For reliable communication, the receiver must find out the errors occurred in the data which is called as error detection.

Error Correction:

It is the mechanism to correct the errors and it can be handled in 2 ways.

- a) When an error is discovered, the receiver can have the sender retransmit the entire data unit.
- b) A receiver can use an error correcting coder, which automatically corrects certain error.

**8. What is the use of two dimensional parity in error detection?**

Two-dimensional parity check increases the likelihood of detecting burst errors. It is used to detect errors occurred in more than one bits.

**9. What are the issues in data link layer?**

The data link layer has a number of specific functions it can carry out. These functions include,

- a) Providing a well-defined service interface to the network layer.
- b) Dealing with transmission errors.
- c) Regulating the flow of data so that slow receivers are not swamped by fast senders.

**10. What are the ways to address the framing problem?**

The framing problem can be addressed by the following protocols:

- Byte-Oriented Protocols(PPP)
- Bit-Oriented Protocols(HDLC)
- Clock-Based Framing(SONET)

**11. What are the responsibilities of data link layer?**

Specific responsibilities of data link layer include the following.

- a) Framing
- b) Physical addressing
- c) Flow control
- d) Error control
- e) Access control

**12. Mention the types of errors.**

There are 2 types of errors

- a) Single-bit error.
- b) Burst-bit error.

**13. Define the following terms.**

*Single bit error:* The term single bit error means that only one bit of a given data unit (such as byte character/data unit or packet) is changed from 1 to 0 or from 0 to 1.

*Burst error:* Means that 2 or more bits in the data unit have changed from 1 to 0 from 0 to 1.

**14. What is redundancy?**

It is the error detecting mechanism, which means a shorter group of bits or extra bits may be appended at the destination of each unit.

**15. What is the purpose of hamming code?**

A hamming code can be designed to correct burst errors of certain lengths. So the simple strategy used by the hamming code to correct single bit errors must be redesigned to be applicable for multiple bit correction.

**16. What is mean by error control?**

Error control is a method that can be used to recover the corrupted data whenever possible. These are two basic types of error control which are backward error control and forward error control.

**17. What is OSI?**

A standard that specifies a conceptual model called Open systems Interconnection network interface model, which breaks networked communications into seven layers: Application, Presentation, Session, Transport, Network, Data link, Physical.

**18. State the major functions performed by the presentation layer of the ISO OSI model.**

(Nov Dec 2006)

Presentation layer is concerned with the format of data exchanged between peers, for example, whether an integer is 16, 32, or 64 bits long and whether the most significant bit is transmitted first or last, or how a video stream is formatted.

**19. State the purpose of layering in networks? (May Jun 2007)**

A layer is a collection of related functions that provides services to the layer above it and receives services from the layer below it.

To execute the functions by each layer is independent.

**20. What are the two fundamental ways by which network performance is measured?**

1. Bandwidth
2. Latency

**PART - B**

**1. Explain ISO/OSI reference model.**

- Physical layer
- Data link layer

- Network layer
- Transport layer
- Session layer
- Presentation layer
- Application layer

2. **Explain the topologies of the network.**

- Mesh topology
- Star topology
- Tree topology
- Bus topology
- Ring topology

3. **Explain the categories of networks.**

- Local Area Network(LAN)
- Metropolitan Area Network(MAN)
- Wide Area Network(WAN)

4. **Explain error detection and error correction techniques.**

Types of errors

- Single bit error
- Burst error

Error detection

- Vertical redundancy check(VRC)
- Longitudinal redundancy check(LRC)
- Cyclic redundancy check(CRC)
- Checksum

Error correction

- Single-bit error correction
- Hamming code
- Burst error correction

5. **Explain error control mechanism.**

- Stop and wait ARQ
- Sliding window ARQ
- Go back-n
- Selective-reject

## UNIT - II

1. **What are the responsibilities of Network Layer?**

The Network Layer is responsible for the source-to-destination delivery of packet possibly across multiple networks (links).

- a. Logical Addressing b. Routing.

2. **What is DHCP?**

The Dynamic Host Configuration Protocol has been derived to provide dynamic configuration. DHCP is also needed when a host moves from network to network or is connected and disconnected from a network.

3. **Define ICMP**

Internet Control Message Protocol is a collection of error messages that are sent back to the source host whenever a router or host is unable to process an IP datagram successfully.

4. **What is the need of internetwork?**

To exchange data between networks, they need to be connected to make an Internetwork.

5. **What are the types of class full addressing?**

The types are Class A, Class B, Class C, Class D, and Class E

- 6. What do you mean by ARP?**

ARP stands for Address resolution protocol. ARP is a dynamic mapping method that finds a physical address for a given a logical address. i.e. mapping IP address to physical address.
- 7. What do you mean by RARP?**

RARP stands for Reverse Address resolution protocol, maps a MAC address to an IP address.
- 8. What are the functions of MAC?**

MAC sub layer resolves the contention for the shared media. It contains synchronization, flag, flow and error control specifications necessary to move information from one place to another, as well as the physical address of the next station to receive and route a packet.
- 9. Define the term medium access control mechanism**

The protocol that determines who can transmit on a broadcast channel are called medium access control (MAC) protocol. The MAC protocols are implemented in the Mac sub-layer which is the lower sub-layer of the data link layer.
- 10. What is bridge?**

Bridge is a hardware networking device used to connect two LANs. A bridge operates at data link layer of the OSI reference model.
- 11. What is a repeater?**

Repeater is a hardware device used to strengthen signals being transmitted on a network.
- 12. Define router**

A network layer device that connects networks with different physical media and translates between different network architecture.
- 13. What is a switch?**

A switch is a networking device that manages networked connections between devices on a star networks.
- 14. What is mean by Ethernet?**

Ethernet is a networking technology developed in 1970 which is governed by the IEEE 802.3 specifications.
- 15. Advantages of Ethernet**
  1. Inexpensive
  2. Easy to install
  3. Supports various writing technologies.
- 16. Identify the class and default subnet mask of the IP address 217.65.10.7.**

IP Address 217.65.10.7 belongs to Class C. Its subnet mask is 255.255.255.0.
- 17. What are the limitations of bridges?**
  1. Scale
  2. Heterogeneity
- 18. Define Bluetooth.**

Bluetooth is a wireless technology standard for exchanging data over short distances (using short-wavelength UHF radio waves in the ISM band from 2.4 to 2.485 GHz) from fixed and mobile devices and building personal area networks (PANs).
- 20. What are the 3 levels of hierarchy in IP Addressing?**
  1. Netid
  2. Subnetid
  3. Hostid
- 21. What are the functions of bridge?**
  1. Connecting networks
  2. Filtering information so that network traffic for one portion of the network does not congest the rest of the network.

## **22. Define sub-netting**

Sub-netting is a technique that allows a network administrator to divide one physical network into smaller logical networks and thus control the flow of traffic for security or efficiency reasons.

### **PART - B**

#### **1. Explain detail about IEEE 802.3 MAC sub-layer**

- Frame format
- Frame length
- Ethernet specifications
- Manchester encoding
- Binary exponential Back off algorithm
- Ethernet performance

#### **2. Explain detail about Bluetooth architecture**

- Radio layer
- Baseband layer
- Frame format
- L2CAP
- Hidden Station Problem

#### **3. Explain about IPv4 address**

- Classful addressing
- Special IP addressing
- Classless addressing
- Header format
- IP fragmentation Options
- Sub-netting a network

#### **4. Explain about Address resolution protocol Packet format**

- Encapsulation
- Proxy ARP

#### **5. Explain about RARP**

- Frame Format of RARP
- Encapsulation

#### **6. Explain about Internet Control Message Protocol**

- Message types
- Message format
- Error Reporting
- Echo Request and reply
- Time stamp request and reply
- Address mask request and reply message.

#### **7. Explain about Ethernet.**

- Access method : CSMA/CD Addressing
- Electrical specification
- Frame format Implementation:
  - 10 base 5:Thick Ethernet
  - 10 base 2: Thin Ethernet,
  - 10 base T : Twisted-pair Ethernet
  - 1 base 5 : Star LAN

### **UNIT - III**

#### **1. What is routing?**

Routing is a process of selecting paths in a network through which network traffic is sent.

#### **2. Define an internetwork.**

A collection of interconnected network is called an internetwork.

#### **3. What does routing metric mean?**

A routing metric is a unit calculated by a routing algorithm for selecting or rejecting a routing path for transferring data/traffic.

**4. What are the metrics used in determining the best path for a routing protocol?**

- Bandwidth
- Delay
- Load
- Reliability
- Cost
- Hop count
- MTU
- Ticks

**5. What is multicasting?**

Multicasting is the delivery of information to a group of destinations simultaneously using the most efficient strategy to deliver the messages over each link of the network only once.

**6. What are different types of multicast routing?**

1. Reverse path multicasting
2. Reverse path broadcasting

**7. What is multicast? What is the motivation for developing multicast?**

Multicasting means delivering the same packet simultaneously to a group of clients. Motivation for developing multicast is that there are applications that want to send a packet to more than one destination hosts.

**8. Define RIP.**

RIP is a dynamic protocol used for finding the best route or path from one-to-end over a network by using a routing metric/ hop count algorithm.

**9. What is OSPF?**

OSPF protocol is a router protocol used within larger autonomous system networks in preference to the Routing Information Protocol (RIP).

**10. What are the features of OSPF?**

- Authentication of routing messages
- Additional hierarchy
- Load balancing

**11. Mention any four applications of multicasting**

- Broad casts of audio and video
- Video conferencing
- Shared Applications.
- IGMP is used by multicast routers to keep track of membership in a multicast group.

**12. Describe the process of routing packets**

Routing is the act of moving information across an internetwork from a source to a destination.

**13. What are the some routing algorithm types?**

The routing types are static, dynamic, flat, hierarchical, host-intelligent, router- intelligent, intra-domain, inter-domain, link state and distance vector.

**14. What is a benefit of DHCP?**

- Simplicity: clients need to manual configuration.
- Mobility and hosts: Hosts may move between networks without reconfiguring.
- Mobility of network: Possible for internet service providers to reconfigure customers address transparently.
- Save address space if individual clients are not always active.

**15. What are the 3 types of routing performed by BGP?**

- Inter-autonomous system routing
- Intra-autonomous system routing

- Pass through autonomous system routing

## 16. What are the different kinds of multicast routing?

- DVMRP
- PIM
- MSDP
- MOSPF
- MBGP

## 17. Write the types of PIM.

- PIM Sparse mode
- PIM Dense mode
- Bidirectional PIM
- Source Specific Multicast (SSM)

## 18. How can the routing be classified?

The routing can be classified as,

- Adaptive routing
- Non-adaptive routing.

## 19. What are the salient features of IPv6?

Salient features are:

- Efficient and hierarchical addressing and routing infrastructures.
- IPv6 networks provide auto configuration capabilities.
- Better support for QOS.
- Large Address space.
- Stateless and stateful address configuration.

## 20. Write the BGP Message types.

- Open
- Update
- Notification
- Keep-alive

## PART - B

### 1.Explain IP addressing method.

Internetwork protocol (IP) Datagram  
Addressing Classes  
Dotted decimal notation

### 2. Define routing & explain distance vector routing and link state routing.

Distance vector routing  
Sharing information  
Routing table:  
Creating the table  
Updating the table:  
Updating algorithm  
Link state routing:  
Information sharing  
Packet cost  
Link state packet:  
Getting information about neighbors  
Initialization Link state database

### 3.Define bridge and explain the type of bridges.

Bridges:  
Types of bridges

Simple bridge  
Multi-port bridge  
Transparent bridge

#### 4. Explains sub-netting

Three levels of hierarchy masking  
Masks without sub-netting  
Masks with sub-netting  
Finding the sub-network address  
Boundary level masking  
Non-boundary level masking

#### 5. Write short notes about repeaters, routers and gateways.

Repeaters  
Routers: Routing concepts  
Least-cost routing  
Non adaptive routing  
Adaptive routing  
Packet lifetime  
Gateways

### UNIT- IV

#### 1. What are the fields on which the UDP checksum is calculated? Why?

UDP checksum includes a pseudo header, the UDP header and the data coming from the application layer.

#### 2. What are the advantages of using UDP over TCP?

- UDP does not include the overhead needed to detect reliability
- It does not need to maintain the unexpected deception of data flow
- UDP requires less processing at the transmitting and receiving of hosts.
- It is simple to use for a network
- The OS does not need to maintain UDP connection information.

#### 2. What is TCP?

TCP provides a connection oriented, reliable byte stream service. The connection oriented means the two applications using TCP must establish a TCP connection with each other before they can exchange data.

#### 3. Define congestion

When too many packets rushing to a node or a part of network, the network performance degrades. This situation is called as congestion.

#### 4. List the flag used in TCP header.

TCP header contains six flags. They are URG, ACK, PSH, RST, SYN, FIN

#### 5. Give the approaches to improve the QoS.

Fine grained approaches, which provide QoS to individual applications or flows. Integrated services, QoS architecture developed in the IETE and often associated with RSVP.

#### 6. What do you mean by QoS?

Quality of Service is used in some organizations to help provide an optimal end user experience for audio and video communications. QoS is most commonly used on networks where bandwidth is limited with a large number of network packets competing for a relatively small amount of available and width.

#### 7. What is multiplexing?

The job of gathering data chunks at the sources host from different sockets, encapsulating each data chunks with header information to create segments, and passing the segments to the network layer is called multiplexing.



- 8. What is de-multiplexing?**  
The job of delivering the data in a transport layer segment to the correct socket is called de-multiplexing.
- 9. What is RTT?**  
RTT is an acronym for Round Trip Time: it is a measure of the time it takes for a packet to travel from a computer, across a network to another computer, and back.
- 10. What is the segment?**  
Transport layer protocols send data as a sequence of packets. In TCP/IP these packets are called segments.
- 11. What is a port?**  
Applications running on different hosts communicate with TCP with the help of a concept called as ports. A port is a 16 bit unique number allocated to a particular application.
- 12. List the services of end to end services.**
- Guarantee message delivery.
  - Delivery messages in the same order they are sent.
  - Deliver at most one copy of each message.
  - Support arbitrarily large message.
  - Support synchronization.
- 13. What is congestion?**  
When load on network is greater than its capacity, there is congestion of data Packets. Congestion occurs because routers and switches have queues or buffers.
- 14. What are the functions of transport layer?**
- Breaks messages into packets.
  - Connection control.
  - Addressing.
  - Provide reliability.
- 15. What are the types of QoS tools?**  
Classification Congestion management,
- Congestion avoidance
  - Shaping/policing
  - Link efficiency
- 16. List some ways to deal with congestion**
- packet elimination
  - Flow control
  - Buffer allocation
  - Choke packets
- 17. Define network congestion?**  
When two or more nodes would simultaneously try to transmit packets to one node there is a high probability that the number of packets would exceed the packet handling capacity of the network and lead to congestion.
- 18. List the three types of addresses in TCP/IP.**  
Three types of addresses are used by systems using the TCP/IP protocol: the physical address, the internetwork address (IP address), and the port address.
- 19. What is the flow characteristics related to QoS?**  
The flow characteristics related to QoS are
- Reliability
  - Delay
  - Jitter

- Bandwidth

**20. What are the techniques to improve QoS?**

The techniques to improve QoS are

- Scheduling
- Traffic shaping
- Resource reservation
- Admission control

**21. Define Socket address.**

The combination of IP address and port address is called Socket address.

**22. What are the two types of protocols used in Transport layer?**

The two types of protocols used in Transport layer are

- TCP
- UDP

**23. Define Throughput.**

It is defines as a number of packets passing through the network in a unit of time.

**24. Define UDP**

User datagram protocol is a Unreliable, connectionless protocol, used along with the IP protocol.

**25. What is the need of port numbers?**

Port numbers are used as an addressing mechanism in transport layer.

**26. What are the types of port numbers used in transport layer?**

- Well-known port
- Registered port
- Dynamic port

**27. Why TCP services are called Stream delivery services?**

TCP allows the sending process to deliver data as a stream of bytes and the receiving process to deliver data as a stream of bytes. So it is called as stream of bytes.

**28. Define jitter**

Jitter is defined as a variation in the delay of received packets. The sending side transmits packets in a continuous stream and spaces them evenly apart. Because of network congestion, improper queuing, or configuration errors, the delay between packets can vary instead of remaining constant.

**29. Compare connectionless service & connection oriented service**

In connection less service there is no connection between transmitter & receiver Ex: UDP

In connection oriented service there is a connection between transmitter & receiver Ex: TCP

**30. What is Unicast & Multicast communication?**

- **Unicast communication** is one source sending a packet to one destination.
  - **Multicast communication** is one source sending a packet to multiple destinations.

**PART - B**

**1. Explain the duties of transport layer.**

- End to end delivery
- Addressing
- Reliable delivery
- Error control
- Sequence control
- Loss control
- Duplication control
- Flow control

**2. Explain UDP & TCP.**

User Datagram Protocol (UDP)

Source port address

Destination port address

Total length

Checksum

Transmission Control Protocol (TCP)

Source port address

Destination port address

Sequence number

Acknowledgement number

Header length

Reserved Control

Window size

Check sum

Urgent pointer

Options and padding

**3. Explain about congestion control.**

Congestion Control

BECN

FECN

Four situations

Discarding

**4. Explain about Congestion Avoidance**

DECbit scheme

RED

**5. Explain detail about QoS Policing**

Integrated service

Traffic Shaping

Admission Control

RSVP

Differentiated Services/Qos

**UNIT - V**

**1. Define the two types of user agents in the electronic mail system**

- Command driven: It normally accepts a one character command from the keyboard to perform its task.
- GUI based: They contain GUI components that allow the user to interact with the software by using both the keyword and mouse.

**2. What is DNS?**

DNS is a client/server application that identifies each host on the internet with a unique user friendly name.

**3. What is the purpose of inverse domain?**

The inverse domain is used to map an address to a name.

**4. What is SMTP?**

Simple Mail Transfer Protocol is a standard and reliable host to host mail transport protocol that operates over the TCP port 25.

**5. State the Purpose of SNMP**

The primary purpose of SNMP is to allow the network administrator to monitor and configure devices on the network, remotely via the network. These configuration and monitoring capabilities are collectively referred to as management.

**6. What is the Domain name system responsible for?**

The Domain Name system converts domain names (of the form [www.vtubooks.com](http://www.vtubooks.com)) into IP numbers.

**7. What are the four main properties of HTTP?**

- Global Uniform Resource Identifier
- Request response exchange.
- Statelessness.
- Resource meta data

**8. What is SMTP used for?**

SMTP is used when email is delivered from an email client, such as Outlook Express, to an email server or when email is delivered from one email server to another.

**9. What is virtual terminal?**

A virtual terminal is a data structure maintained by either the application software or a local terminal.

**10. What are the basic functions of email?**

Composition, Transfer, Reporting, Displaying and Disposition of mails.

**11. Define WWW?**

It is an internet application that allows users to view web pages and move from one web page to another.

**12. What is the web browser?**

Web browser is a software program that interprets and displays the contents of HTML web pages.

**13. What is URL?**

URL is a string identifier that identifies a page on the World Wide Web.

**14. What do you mean by TELNET?**

TELNET is used to connect remote computers and issue commands on those computers.

**15. What are the responsibilities of Application Layer?**

The Application Layer enables the user, whether human or software, to access the network. It provides user interfaces and support for services such as e-mail, shared database management and other types of distributed information services

- Network virtual Terminal,
- File transfer, access and Management (FTAM),
- Mail services,
- Directory Services

**6. Write down the three types of WWW documents.**

The documents in the WWW can be grouped into three broad categories: static, dynamic and active.

- A) *Static*: Fixed-content documents that are created and stored in a server.
- B) *Dynamic*: Created by web server whenever a browser requests the document.
- C) *Active*: A program to be run at the client side.

**7. What is fully Qualified Domain Name?**

If a label is terminated by a null string is called a Fully Qualified Domain Name.

**8. What is Generic Domains?**

Generic domain defines registered hosts according to their generic behavior. Each node in the tree defines a domain, which is an index to the domain name space database. Eg.-

- com – Commercial organizations,
- edu - Educational institutions,
- gov – Government Institutions.

9. **What is simple mail transfer protocol?**  
The TCP/IP protocol that supports electronic mail on the internet is called Simple Mail Transfer Protocol (SMTP). It is a system for sending messages to other computer users based on email addresses.
20. **What do you mean by File transfer protocol?**  
It is a standard mechanism provided by the internet for copying a file from one host to another.
21. **What are the two types of connections in FTP?**  
The two types of connections in FTP are
- Control connection
  - Open connection
22. **Define HTTP.**  
It is used mainly to access data on the World Wide Web. The protocol transfers data in the form of plaintext, hypertext, audio, video and soon.
23. **What are the types of messages in HTTP transaction?**  
The types of messages in HTTP transaction are
- Request messages
  - Response messages
24. **What are the parts of a browser?**  
The parts of a browser are
- A controller
  - A client program
  - Interpreter
25. **Name the four aspects of security.**
- Privacy
  - Authentication
  - Integrity
  - Non-repudiation
26. **What is POP?**  
Post Office Protocol, version3 (POP3) and Internet Mail Access Protocol version4 (IMAP4) are protocol used by a mail server in conjunction with SMTP to receive and hold mail for hosts.
27. **What is the function of SMTP?**  
The TCP/IP protocol supports electronic mail on the Internet is called Simple Mail Transfer (SMTP). It is a system for sending messages to other computer users based on email addresses. SMTP provides mail exchange between users on the same or different computers.
28. **How does MIME enhance SMTP?**  
MIME is a supplementary protocol that allows non-ASCII data to be sent through SMTP. MIME transforms non-ASCII data at the sender site to NVT ASCII data and delivers it to the client SMTP to be sent through the Internet. The server SMTP at the receiving side receives the NVT ASCII data and delivers it to MIME to be transforming feed back to the original data.
29. **Why is an application such as POP needed for electronic messaging?**  
Workstations interact with the SMTP host, which receives the mail on behalf of every host in the organization, to retrieve messages by using a client-server protocol such as Post Office Protocol, version 3(POP3). Although POP3 is used to download messages from the server, the SMTP client still needed on the desktop to forward messages from the workstation user to its SMTP mail server.

## **PART - B**

1. **Explain the functions of SMTP.**  
System for sending messages to other computer users based on e-mail addresses.  
SMTP provides mail exchange between users on the same or different computers.  
User Agent

Mail Transfer Agent  
Multipurpose Internet Mail Extensions  
Post Office Protocol

2. **Write short notes on FTP.**  
Transfer a file from one system to another.  
TCP connections  
Basic model of FTP
3. **Explain about HTTP.**  
HTTP transactions  
HTTP messages  
URL
4. **Explain the WWW in detail.**  
Hypertext & Hypermedia  
Browser Architecture  
Categories of Web Documents  
HTML  
CGI Java
5. **Explain about Electronic mail**  
Email addressing  
Message headers  
Formatted email  
Functions of email  
User agent and message transfer agent  
Simple mail Transfer protocol  
Multipurpose internet mail extensions  
Post Office Protocol (POP)  
IMAP
6. **Explain detail about Domain Name System**  
Components of DNS  
DNS in the internet Name space  
Domain name Space Resolution  
Message format Resource records  
Name servers  
Dynamic Domain Name system (DDNS)

## **GRAPHICS AND MULTIMEDIA**

### **UNIT I - OUTPUT PRIMITIVES PART A**

#### **1. What is the purpose of presentation graphics?**

Presentation graphics is used to produce illustrations for reports or to generate 35- mm slides or transparencies for use with projectors. Presentation graphics is commonly used to summarize financial, statistical, mathematical, scientific, and economic data for research reports, managerial reports, consumer information bulletins, and other types of reports.

#### **2. Define refresh buffer/frame buffer.**

The memory area where in picture definition is stored is called Refresh buffer. This memory area holds the set of intensity values for all the screen points. On a black and white system with one bit per pixel, the frame buffer is called a bitmap.

#### **3. What is pixel?**

Each screen point in a monitor is called a pixel/pel. It is also called picture element.

#### **4. Define aspect ratio.**

It is a property of video monitors. This number gives the ratio of vertical points to horizontal points necessary to produce equal-length lines in both directions on the screen.

#### **5. What is Output Primitive?**

Basic geometric structures that describe a scene are referred to as Output Primitives. Points and straight lines segments are the simplest geometric components of pictures. Additional output primitives that can be used to construct a picture include circles and other conic sections, quadric surfaces, spline curves and surfaces, polygon color areas, and character strings.

#### **6. What is DDA?**

The Digital Differential Analyzer is a scan-conversion line algorithm based on calculating either difference in y-coordinate (dy) or difference in x-coordinate. We sample the line at unit intervals in one coordinate and determine corresponding integer values nearest the line path for the other coordinate.

#### **7. What are the disadvantages of DDA algorithm?**

- Round-off error in successive additions of the floating-point increment can cause the calculated pixel positions to drift away from the true line path for long line segments.
- Rounding operations and floating-point arithmetic in procedure are still time consuming.

#### **8. What is attribute parameter?**

Any parameter that affects the way a primitive is to be displayed is referred to as an attribute parameter.

#### **9. What is the basic line attributes?**

Basic attributes of a straight line segment are its type, its width, and its color.

#### **10. What is meant by aliasing?**

The distortion of information due to low frequency sampling (Under sampling) is called aliasing. We can improve the appearance of displayed raster lines by applying antialiasing methods that compensate for the under sampling process.

#### **11. Define Translation.**

A translation is applied to an object by repositioning it along a straight line path from one coordinate location to another. We translate a two-dimensional point by adding translation distances,  $t_x$  and  $t_y$ , to original coordinate position  $(x, y)$  to move the point to a new position  $(x', y')$ .  $x' = x + t_x$ ,  $y' = y + t_y$ . The translation distance pair  $(t_x, t_y)$  is called a translation vector or shift vector.

#### **12. Define Rotation.**

A 2-D rotation is applied to an object by repositioning it along a circular path in the xy plane.

#### **13. Define Scaling.**

A scaling transformation alters the size of an object. This operation can be carried out for polygons by multiplying the coordinate values  $(x, y)$  of each vertex by scaling factors  $s_x$  and  $s_y$  to produce the transformed coordinates  $(x', y')$ .  $x' = x \cdot s_x$ ,  $y' = y \cdot s_y$ .

#### **14. Define Reflection.**

A Reflection is a transformation that produces a mirror image of an object. The mirror image for a 2D reflection is generated relative to an axis of reflection by rotating the object 180 degree about the reflection axis.

#### **15. Define Shear.**

A transformation that distorts the shape of an object such that the transformed shape appears as if the object were composed of internal layers that had been caused to slide over each other is called a shear.

#### **16. Define Window.**

A world-coordinate area selected for display is called a window.

#### **17. Define view port.**

An area on a display device to which a window is mapped is called a view port.

### **18. What is viewing transformation?**

The mapping of a part of a world-coordinate scene to device coordinates is referred to as viewing transformation.

### **19. Define Clipping.**

Any procedure that identifies those portions of a picture that are either inside or outside of a specified region of space is referred to as a clipping algorithm or simply clipping. The region against which an object is clipped is called a clip window.

### **20. What are the types of Clipping?**

- Point clipping
- Line clipping
- Area clipping
- Curve clipping
- Text clipping

## **PART B**

### **1. Explain DDA algorithm for line.**

### **2. Explain Bresenham's algorithm for line, circle, ellipse.**

### **3. Explain Attributes of Output primitives.**

### **4. Explain 2D Transformations.**

### **5. Explain 2D viewing.**

## **UNIT II - THREE DIMENSIONAL CONCEPTS**

### **PART A**

### **1. Categorize the 3D representations?**

Boundary representation (B-reps) and space-partitioning representations.

### **2. What Boundary representation?**

It describes a 3D object as a set of surfaces that separate the object interior from the environment. e.g. polygon facets and spline patches.

### **3. What space-partitioning representation?**

This is used to describe interior properties, by partitioning the spatial region containing an object into a set of small, non-overlapping, contiguous solids. e.g. octree.

### **4. What is Blobby Object?**

Some objects do not maintain a fixed shape, but change their surface characteristics in certain motions or when in proximity to other objects. Examples in this class of objects include molecular structures, water droplets and other liquid effects, melting objects and muscle shapes in the human body. These objects can be described as exhibiting "blobbiness" and are often simply referred to as blobby objects, since their shapes show a certain degree of fluidity.

### **5. What is projection?**

The process of displaying 3D objects on a 2D display is called as Projection

### **6. What are the types of projection?**

- Perspective projection
- Parallel projection

### **7. What is parallel projection?**

In a parallel projection, coordinate positions are transformed to the view plane along parallel lines.

### **8. What is Perspective projection?**

For a perspective projection object positions are transformed to the view plane along lines that converge to a point called the projection reference point.



### 9. What is chromaticity?

The term chromaticity is used to refer collectively to the two properties describing color characteristics: Purity and dominant frequency.

### 10. Define Color model.

A Color model is a method for explaining the properties or behavior of color within some particular context.

### 11. What are the uses of chromaticity diagram?

The chromaticity diagram is useful for the following:

- Comparing color gamuts for different sets of primaries.
- Identifying complementary colors.
- Determining dominant wavelength and purity of a given color.

### 12. Give the transformation matrix for conversion of RGB to YIQ.

$$\begin{pmatrix} Y \\ I \\ Q \end{pmatrix} = \begin{pmatrix} 0.299 & 0.587 & 0.144 \\ 0.596 & 0.275 & -0.321 \\ 0.212 & -0.528 & 0.311 \end{pmatrix} \cdot \begin{pmatrix} R \\ G \\ B \end{pmatrix}$$

### 13. What is HSV model?

The HSV(Hue,Saturation,Value) model is a color model which uses color descriptions that have a more intuitive appeal to a user. To give a color specification, a user selects a spectral color and the amounts of white and black that are to be added to obtain different shades, tint, and tones.

### 14. What for CMY color model used?

A color model defined with the primary colors cyan, magenta, and yellow is useful for describing color output to hard-copy devices.

### 15. What are the parameters in the HLS color model?

Hue, Lightness and Saturation.

### 16. Define Computer animation.

Computer animation refers to any time sequence of visual changes in a scene. In addition to changing object position with translations or rotations, a computer generated animation could display time variations in object size, color, transparency, or surface texture.

### 17. What are the steps in animation sequence?

- Story board layout
- Object definition
- Key-frame specifications
- Generation of in-between frames

### 18. How frame-by-frame animation works?

Here each frame of the scene is separately generated and stored. Later the frames can be recorded on film or they can be consecutively displayed in "real-time playback" mode.

### 19. What is morphing?

Transformation of object shapes from one form to another is called morphing.

### 20. What are the methods of motion specifications?

- Direct motion specification
- Goal-directed Systems
- Kinematics and Dynamics.

## PART B

### 1. Explain various 3D object representations.

### 2. Explain 3D Transformations.

3. Explain 3D viewing.
4. Explain Color models.
5. Explain computer animation.

## UNIT III - MULTIMEDIA SYSTEM DESIGN PART A

### 1. Give some Multimedia applications.

- Document imaging
- Image processing and Image recognition
- Full-Motion Digital Video Applications
- Electronic Messaging

### 2. What are the multimedia elements?

Facsimile, Document images, Photographic images, Geographical information system maps, Voice commands and voice synthesis, Audio messages, Video messages, Full-motion stored and live video, Holographic images, Fractals.

### 3. What is Holography?

It is defined as the means of creating a unique photographic image without the use of a lens.

### 4. What is hologram?

The photographic recoding of the image is called a hologram, which appears to be an unrecognizable pattern of stripes and whorls but which when illuminated by coherent light as by a laser beam, organizes the light in to 3D representation of the original object.

### 5. What are the important processes in image processing?

Image recognition, image enhancement, image synthesis, and image reconstruction.

### 6. What are complex image enhancement capabilities?

Image calibration, Real-time alignment, Gray-scale normalization, RGB hue intensity adjustment, Color separation, Frame averaging.

### 7. What is VGA mixing?

Here, the image acquisition memory also serves as the display source memory, thereby fixing its position and size on screen.

### 8. What is Dual-buffered VGA mixing / scaling?

Double buffer schemes maintain the original images in a decompression buffer and the resized image in a display buffer.

### 9. What is hypermedia documents?

In hypermedia documents in addition to text, embedded or linked multimedia objects such as image, audio, hologram, or full -motion video.

### 10. What are the sub-systems in DSP?

Memory management, hardware-interrupt handling, Multitasking, Inter task synchronization and communication, Multiple timer services, Device-independent I/O.

### 11. What are the types of images based on multimedia?

Visible images, non-visible images, abstract images.

### 12. What does non-visible images refer?

Non-visible images are those that are not stored as images but are displayed as images e.g. pressure gauges, temperature gauges.

### 13. What are abstract images?

Abstract images are really not images that ever existed as real-world objects or representations. Rather they are computer-generated images based on some arithmetic calculations. e.g. fractals.

**14. What is DVI?**

The Digital Video Interface (DVI) standard was defined to provide a processor independent specification for a video interface that could accommodate most compression algorithms for fast multimedia displays.

**15. What is MIDI?**

This is the interface standard for file transfer between a computer and a musical instrument such as a digital piano.

**16. What is Apple's Quick time?**

The QuickTime standard, developed by Apple Computer, is designed to support multimedia applications. Apple's QuickTime is viewed as a multimedia interface that is evolving to become a standard part of the Apple as well as MS-Windows based systems.

**17. What is JPEG?**

The Joint Photographic Experts Group, formed as a joint ISO and CCITT working committee, is focused exclusively on still-image compression.

**18. What is called Asymmetrical compression based on Compression?**

These are applications that need to be compressed once but are read many times.

**19. What are the considerations in Multimedia storage?**

Massive storage volumes, large object sizes, multiple related objects, temporal requirements for retrieval.

**20. What are the strengths of object oriented s/w?**

Encapsulation, Association, Classification.

**PART B**

- 1. Give the multimedia applications and explain.**
- 2. What are the multimedia elements? Explain.**
- 3. Explain about Multimedia databases.**
- 4. Explain about defining objects for multimedia system.**
- 5. Explain about Multimedia data interface standards?**

**UNIT IV-MULTIMEDIA FILE HANDLING****PART A****1. Define Cadence.**

Cadence is a term used to define the regular rise and fall in the intensity of sound.

**2. Say some loss less compression standards?**

Pack bits encoding, CCITT Group3 1D, CCITT Group3 2D, CCITT Group4, Lempel-Ziv and Welch algorithm LZW.

**3. Say some lossy compression standards?**

JPEG(Joint photographic Experts Group), MPEG(Moving Picture Experts Group), Intel DVI, CCITT H.261 video coding algorithm, Fractals.

**4. What are the advantages of CCITT Group 3 1D?**

- It is simple to implement in both h/w and s/w.
- It is a world wide standard for facsimile, which is accepted for document imaging application. This allows document-imaging applications to incorporate fax documents easily.

**5. What is the disadvantage of CCITT Group 3 2D Scheme?**

It is complex and relatively difficult to implement in software.

**6. What is Luminance?**

Luminance refers to brightness. This is a measure of the brightness of the light emitted or reflected by an object.

**7. What are the levels of definition in JPEG standards?**

Baseline system, Extended system, special loss less function.

**8. Define Quantization.**

It is a process of reducing the precision of an integer, thereby reducing the number of bits required to store the integer.

**9. What are the controls in VCR paradigm?**

Play, fast, forward, rewind, search forward, and rewind search.

**10. What are types of moving picture?**

Intra picture, Unidirectional predicted pictures, Bi-directional predicted pictures.

**11. What are the factors that affect video performance?**

Microprocessor speed, Play back window size, Frame rate.

**12. What is fractal?**

A fractal is a multidimensional object with an irregular shape or body that has approximately the same shape or body irrespective of size. i.e., irrespective of whether it gets smaller or bigger in size.

**13. What are multimedia file formats?**

Rich-Text Format(RTF), Tagged image file format(TIFF), Resource image file format(RIFF), Musical instrument digital interface(MIDI), Joint Photographic Experts Group, Audio Video Interchanged Indeo file Format(AVI), TWAIN.

**14. What is digital pen?**

A digital pen is a powerful input device that allows the user to write, draw, point and gesture.

**15. What are the components of PEN?**

Electronic pen and digitizer, Pen driver, Recognition context manager, Recognizer, Dictionary, Display driver.

**16. What are the display performance issues?**

N/w b/w, Decompression or decoding, Display technology.

**17. What is roping?**

Roping causes straight lines to appear twisted or helical. This is caused by poor convergence as successive pixels in the line show different edge colors.

**18. Write the four basic technologies used for flat panel displays.**

Passive-matrix monochrome, Active-matrix monochrome, Passive-matrix color, Active-matrix color.

**19. What are the components of Laser printer?**

Paper feed mechanism, Laser assembly, Corona assembly, Fuser, Toner artridge.

**20. What are the main characteristics of voice recognition system?**

Separation b/w words, Speaker dependency and speaker-independent recognition, Use of phonemes, Vocabulary size.

**PART B**

**1. Give in detail Huffman encoding.**

**2. Explain fractal compression.**

**3. Explain data and file format standards.**

**4. Explain about Digital pen.**

**5. Explain about cache management for storage systems.**

# UNIT V-HYPERMEDIA

## PART A

### **1. What are the design issues for multimedia authoring?**

Display resolution, Data formats for captured data, Compression algorithms, Network interfaces, and Storage formats.

### **2. What are the types of Multimedia authoring Systems?**

Dedicated Authoring system, Timeline-Based Authoring, Structured Multimedia Authoring, Programmable Authoring Systems, Multisource Multi-User Authoring systems, Telephone Authoring Systems.

### **3. Classify the User interface development tools?**

Media editors, An authoring application, Hypermedia object creation, Multimedia object locator and browser.

### **4. What is the purpose of zooming?**

Zooming allows the user to see more detail for a specific area of the image.

### **5. What is panning?**

Panning implies that the image window is unable to display the full image at the selected resolution for display. In that case the image can be panned left to right or right to left as well as top to bottom or bottom to top. Panning is useful for finding detail that is not visible in the full image.

### **6. What are the steps needed for Hypermedia report generation?**

Planning, Creating each component, Integrating components.

### **7. Define mail message.**

Mail message is a message of a well-defined type that must include a message header and may include note parts, attachments, and other application-defined components. Note parts may include text, bitmaps, pictures, sound, and video components.

### **8. What are the components of a distributed Multimedia system?**

Application s/w, Container object store, Image and still video store, Audio and video component store, Object directory service agent, Component service agent, User interface service agent, Networks.

### **9. What are the characteristics of Document store?**

Primary document storage, Linked object storage, Linked object management.

### **10. What are key issues in data organization for multimedia systems?**

Data independence, Common Distributed Database Architecture, Multiple Data servers.

### **11. What are the key elements in object server architecture of multimedia applications?**

Multimedia application, Common object management, Object request broker, Object name server, Object directory manager, Object server, Object manager, Network manager, Object data store.

### **12. What are the functions performed by object request broker?**

Object recompilation, Playback control, Format conversion.

### **13. What are the issues in database replication techniques?**

Sharing of all data objects by all users on the networks, Providing acceptable performance to all users, allowing all users to update the database depending on the tasks being performed by them.

### **14. What are the types of database replication?**

Round-robin replication, manual replication, scheduled replication, immediate replication, replication-on-demand, predictive replication, replicating references, no replication.

### **15. What are the primary n/w topologies used for multimedia?**

Traditional LANS, extended LANS, High-speed LANS, WANS.

**16. Give the primary goal of MAPI.**

Separate client applications from the underlying messaging services, Make basic mail-enabling a standard feature for all applications, Support messaging-reliant workgroup applications.

**17. What is the purpose of MIME?**

Multipurpose Internet Mail Extension specification defines mechanisms for generalizing the message content to include multiple body parts and multiple data types.

**18. What are the characteristics of image and still video stores ?**

Compressed information, Multi-image documents, Related annotations, Large volumes, Migration b/w high-volume media such as an optical disk library and high speed media such as magnetic cache storage, shared access.

**19. What are the services provided by a directory service agent?**

Directory service, Object assignment, Object status management, Directory service domains, Directory service server elements, n/w access.

**20. What are the services provided by User Interface Agent?**

Window management, Object creation and capture, Object display and play back, Services on workstations, Using display s/w.

**PART B**

- 1. Explain hypermedia messaging.**
- 2. Explain the components of distributed multimedia systems.**
- 3. Give the multi server n/w topologies.**
- 4. Explain Distributed Client-server operation.**
- 5. How to manage Distributed objects.**

**OBJECT ORIENTED ANALYSIS AND DESIGN**

**UNIT-I**

**Introduction to OOAD**

**1. What is the critical ability of an object oriented system?**

A critical ability of Object Oriented development is to skilfully assign responsibilities to software objects. It is one activity that must be performed either while drawing a UML diagram or programming and it strongly influences the robustness, maintainability, and reusability of software components.

**2. What is meant by object oriented system development methodology?**

Object oriented system development methodology is a way to develop software by building self-contained modules or objects that can be easily replaced, modified and reused.

**3. What is meant by analysis and design?**

Analysis emphasizes an investigation of the problem and requirements, rather than a solution. For example, if a new online trading system is desired, Analysis answers the following questions: How will it be used? & what are its functions?

"Analysis" is a broad term, and it is referred as requirements analysis (an investigation of the requirements) or object-oriented analysis (an investigation of the domain objects).

Design emphasizes a conceptual solution (in software and hardware) that fulfils the requirements, rather than its implementation. For example, a description of a database schema and software objects. Design ideas often exclude low-level or "obvious" details obvious to the intended consumers.

Ultimately, designs can be implemented, and the implementation (such as code) expresses the true and complete realized design.

Useful analysis and design have been summarized in the phrase do the right thing (analysis), and do the things right (design).

## What is OOAD?

### **4. What is object oriented analysis and design?**

During object-oriented analysis there is an emphasis on finding and describing the objects or concepts in the problem domain. For example, in the case of the flight information system, some of the concepts include Plane, Flight, and Pilot.

During object-oriented design (or simply, object design) there is an emphasis on defining software objects and how they collaborate to fulfil the requirements. For example, a Plane software object may have a tailNumber attribute and a get Flight History method.

### **5. Define – Domain Model**

Domain Model is defined as a visualization of the concepts or mental models of a real-world domain and it is also called a conceptual object model. Object-oriented analysis is concerned with creating a description of the domain from the perspective of objects. There is an identification of the concepts, attributes, and associations that are considered noteworthy. The result can be expressed in a domain model that shows the noteworthy domain concepts or objects. It can be noted that a domain model is not a description of software objects.

## What is UML?

### **6. What is UML?**

(M/J – 12)

The Unified Modeling Language (UML) is a visual language for specifying, constructing and documenting the artifacts of systems.

The word visual in the definition is a key point - the UML is the de facto standard diagramming notation for drawing or presenting pictures (with some text) related to software primarily OO software.

### **7. What are the three ways to apply UML?**

The three ways to apply UML are:

- 1) UML as sketch – Informal and incomplete diagrams (often hand sketched on whiteboards) created to explore difficult parts of the problem or solution space, exploiting the power of visual languages.
- 2) UML as blueprint – It is a relatively detailed design diagrams used either for,
  - (i) Reverse engineering to visualize and better understanding existing code in UML diagrams
  - (ii) Code generation (forward engineering)

If reverse engineering, a UML tool reads the source or binaries and generates (typically) UML package, class, and sequence diagrams. These "blueprints" can help the reader understand the big picture elements, structure, and collaborations.

Before programming, some detailed diagrams can provide guidance for code generation (e.g., in Java), either manually or automatically with a tool. It's common that the diagrams are used for some code, and other code is filled in by a developer while coding (perhaps also applying UML sketching).

- 3) UML as programming language – Complete executable specification of a software system in UML. Executable code will be automatically generated, but is not normally seen or modified by developers; one works only in the UML "programming language." This use of UML requires a practical way to diagram all behaviour or logic (probably using interaction or state diagrams), and is still under development in terms of theory, tool robustness and usability.

### **8. What are the three perspectives to apply UML?**

The three perspectives to apply UML are,

- 1) Conceptual perspective the diagrams are interpreted as describing things in a situation of the real world or domain of interest.
- 2) Specification (software) perspective the diagrams (using the same notation as in the conceptual Perspective) describe software abstractions or components with specifications and interfaces, but no commitment to a particular implementation (for example, not specifically a class in C# or java.
- 3) Implementation (software) perspective the diagrams describe software implementations in a particular technology (such as Java).

## 9. Define – Conceptual Class, Software Class and Implementation Class

1) **Conceptual class** – real world concept or thing. A conceptual or essential perspective.

**The UP Domain Model contains conceptual classes.**

2) **Software class** – a class representing a specification or implementation perspective of software component, regardless of the process or method.

3) **Implementation class** – a class implemented in a specific OO language such as Java.

### What is the Unified process (UP) phases?

#### 10. Define – Unified Process (UP)

The Unified Process is defined as a popular iterative software development process for building object-oriented systems. In particular, the Rational Unified Process or RUP, a detailed refinement of the Unified Process, has been widely adopted.

The UP is very flexible and open, and encourages including skilful practices from other iterative methods, such as from Extreme Programming (XP), Scrum, and so forth. For example, XP's test-driven development, refactoring and continuous integration practices can fit within a UP project. So can Scrum's common project room ("war room") and daily Scrum meeting practice.

The UP combines commonly accepted best practices, such as an iterative lifecycle and risk-driven development, into a cohesive and well-documented process description.

#### 11. What is the importance of the unified process?

The importance of the Unified Process (UP) is,

- 1) The UP is an iterative process. Iterative development influences how to introduce OOAD, and to understand how it is best practiced.
- 2) UP practices provide an example structure for how to do and thus how to explain OOAD.
- 3) The UP is flexible, and can be applied in a lightweight and agile approach that includes practices from other agile methods (such as XP or Scrum).

#### 12. What is iterative and evolutionary development?

A key practice in both the UP and most other modern methods is iterative development. In this lifecycle approach, development is organized into a series of short, fixed-length (for example, three-week) mini-projects called iterations; the outcome of each is a tested, integrated, and executable partial system. Each iteration includes its own requirements analysis, design, implementation, and testing activities.

The iterative lifecycle is based on the successive enlargement and refinement of a system through multiple iterations, with cyclic feedback and adaptation as core drivers to converge upon a suitable system. The system grows incrementally over time, iteration by iteration, and thus this approach is specifications and design, it is also known as iterative and evolutionary development.

#### 13. What are the benefits of iterative development?

The benefits of iterative development are,

- 1) Less project failure, better productivity, and lower defect rates; shown by research into iterative and evolutionary methods
- 2) Early rather than late mitigation of high risks (technical, requirements, objectives, usability, and so forth) early visible progress
- 3) Early feedback, user engagement, and adaptation, leading to a refined system that more closely meets the real needs of the stakeholders
- 4) Managed complexity; the team is not overwhelmed by "analysis paralysis" or very long and complex steps
- 5) The learning within an iteration can be methodically used to improve the development process itself, iteration by iteration

#### 14. What are agile methods?

Agile development methods usually apply time boxed iterative and evolutionary development, employ adaptive planning, promote incremental delivery, and include other values and practices that encourage agility, rapid and flexible response to change.

Agile methods share best practices like evolutionary refinement of plans, requirements, and design. In addition, they promote practices and principles that reflect an agile sensibility of simplicity, lightness, communication, self-organizing teams, and more.



**15. List any five agile principles.**

The five agile principles are,

- 1) Satisfy the customer through early and continuous delivery of valuable software
- 2) Agile processes harness change for customer's competitive advantage
- 3) Deliver working software frequently
- 4) Agile software promote sustainable development
- 5) The best, architecture, requirements, and designs emerge from self-organizing teams

**16. Define – Agile Modelling**

The very act of modeling can and should provide a way to better understand the problem or solution space. The purpose of doing UML is to quickly explore (more quickly than with code) alternatives and the path to a good OO design. Many agile methods, such as feature-driven Development, DSDM, and Scrum include significant modelling sessions. The purpose of modelling is primarily support understanding and communication, not documentation.

**17. List the other Critical UP practices.**

(2 Marks)

The idea for UP practice is short time boxed iterative, evolutionary, and adaptive development.

Some additional best practices and key ideas in UP are,

- 1) Tackle high-risk and high-value issue in early iterations
- 2) Continual evaluation, feedback and requirements from users
- 3) Build cohesive, core architecture in early iterations
- 4) Continuously verify quality; test early, often and realistically
- 5) Practice Change Request and Configuration Management

**18. List the different types of UP phases.**

(2 Marks)

An UP Project organizes work and iterations across four major phases are,

- 1) Inception – approximate Vision, Business case, scope, vague estimates
- 2) Elaboration – Refined Vision, iterative implementation of the core architecture, resolution of high risks, identification of most requirements and scope, more realistic estimates
- 3) Construction – Iterative implementation of the remaining lower risk and easier elements, and preparation for deployment
- 4) Transition – beta tests, deployment

**19. List the types of UP disciplines.**

(2 Marks)

Some of the artifacts in the following Disciplines are:

- 1) Business Modelling – The Domain Model artifact, to visualize noteworthy concepts in the application domain
- 2) Requirements – The Use Case Model and Supplementary specification artifacts to capture functional and non-functional requirements
- 3) Design – The Design Model artifact, to design the software artifacts
- 4) Implementation – Programming and building the system, not deploying it

**20. What does Use case Diagram represent? Give an example.**

(2 Marks)

The UML provides use case diagram notation to illustrate the names of use cases and actors, and the relationships between them.

Guideline:

A simple use case diagram is drawn in conjunction with an actor-goal list.

A use case diagram is an excellent picture of the system context; it makes a good context diagram that is, showing the boundary of a system, what lies outside of it, and how it gets used. It serves as a communication tool that summarizes the behaviour of a system and its actors. A sample partial use case context diagram for the NextGen system is shown below.

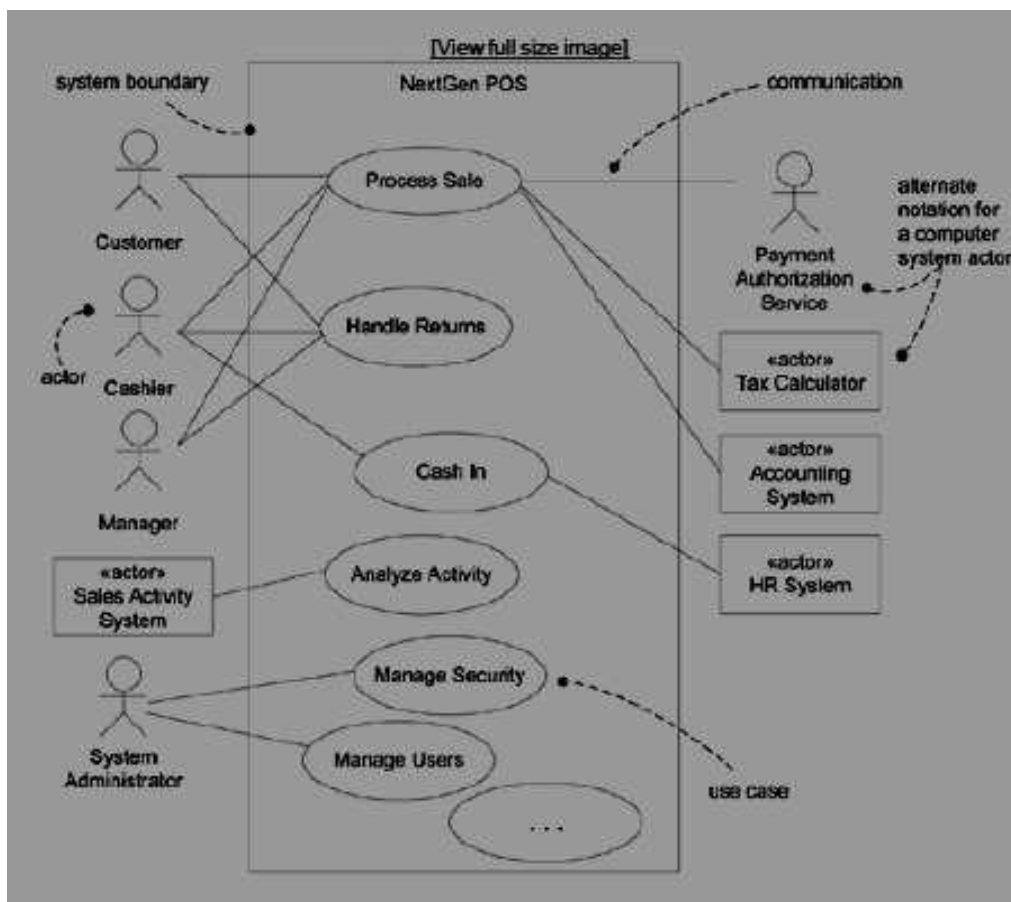

## UML activity diagrams and modelling

**21. What is an UML activity diagram?** (2 Marks)

A UML activity diagram shows sequential and parallel activities in a process. They are useful for modeling business processes, workflows, data flows, and complex algorithms.

**22. State the role and application of activity diagrams.** (2 Marks)

A UML activity diagram offers rich notation to show a sequence of activities, including parallel activities. It may be applied to any perspective or purpose, but is popular for visualizing business workflows and processes, and use cases.

**23. Define – Swim Lane** (N/D – 11, N/D – 12) (2 Marks)

A swim lane (or swimlane) is defined as a visual element used in process flow diagrams, or flowcharts that visually distinguishes responsibilities for sub-processes of a business process. Swim lanes may be arranged either horizontally or vertically.

**24. What is business object model?** (2 Marks)

The UP Domain Model is a specialization of the UP Business Object Model (BOM) "focusing on explaining 'things' and products important to a business domain" [RUP]. That is, a Domain Model focuses on one domain, such as POS related things. The more broad BOM, is an expanded, often very large and difficult to create, multi-domain model that covers the *entire* business and all its sub domains.

**25. List the elements in activity modelling.** (2 Marks)

An activity diagram may have the following elements:

1. Activity states represent the performance of an activity or step within the workflow.
2. Transitions show what activity state follows another. This type of transition can be referred to as a completion transition. It differs from a transition in that it does not require an explicit trigger event; instead it's triggered by the completion of the activity that the activity state represents.
3. Decisions for which a set of guard conditions are defined. Guard conditions

control which transition, of a set of alternative transitions, follows once the activity is complete. You may also use the decision icon to show where the threads merge again. Decisions and guard conditions allow you to show alternative threads in the workflow of a business use case.

4. Synchronization bars are used to show parallel sub flows. Synchronization bars allow you to show concurrent threads in the workflow of a business use case.

### **UML State Diagrams and Modeling**

#### **26. What are UML state machine diagrams?**

(N/D – 12)(2

Marks)

A UML state chart diagram illustrates the interesting events and states of an object, and the behavior of an object in reaction to an event. Transitions are shown as arrows, labeled with their event. States are shown in rounded rectangles.

#### **27. Define – Event, State and Transition**

(A/M – 11, M/J – 12) (2

Marks)

An event is defined as a significant or noteworthy occurrence. It is a label associated with a transition that identifies the message which causes a state change. Example: A telephone receiver is taken off the hook.

A state is defined as the condition of an object at a moment in time, the time between events. Example: A telephone is in the state of being "idle" after the receiver is placed on the hook and until it is taken off the hook.

A transition is defined as a relationship between two states that indicates that when an event occurs, the object moves from the prior state to the subsequent state. Example: When the event "off hook" occurs, transition the telephone from the "idle" to "active" state.

### **UML Deployment and Component Diagrams**

#### **28. What are deployment diagrams?**

(2 Marks)

A deployment diagram shows the assignment of concrete software artifacts (such as executable files) to computational nodes (something with processing services). It shows the deployment of software elements to the physical architecture and the communication (usually on a network) between physical elements.

#### **29. What is component diagram?**

(M/J – 12)(2 Marks)

The component diagram helps to model the physical aspect of an Object-Oriented software system. It illustrates the architectures of the software components and the dependencies between them.

#### **30. Define – Component**

(N/D – 11, N/D – 12) (2

Marks)

A component is defined as a modular part of a system that encapsulates its contents and whose manifestation is replaceable within its environment. A component defines its behavior in terms of provided and required interfaces.

#### **31. What is meant by an axiom? List the two design axioms of object oriented design.**

(2

Marks)

An axiom is a fundamental truth that always is observed to be valid and for which there is no counter example or exception. Two design axioms of object oriented design are:

Axiom 1: The independence

axiom Axiom 2: The  
information axiom

### **PART- B**

#### **1. Explain about POS generation systems.**

- The Next Gen POS System
- Architectural Layers and Case Study Emphasis
- Iterative Development and Iterative Learning

## 2. Define Inception. Explain about artifacts of Inception

- Inception: An Analogy
- What Artifacts May Start in Inception
- You Didn't Understand Inception When...

## 3. Explain about Unified process phases. APRIL/MAY-2011

- Iterative improvement
- UP Practices and Concepts
- The UP Phases and Schedule
- The UP Disciplines (was Workflows)
- The Agile UP
- The Sequential "Waterfall"

## 4. Explain about Use-Case Model and its Writing Requirements in Context. APRIL/MAY-2011

- Background
- Use Cases and Adding Value
- Use Cases and Functional Requirements
- Use Case Types and Formats
- Fully Dressed Example: Process Sale
- Relating use cases- Include, Exclude, Generalize
- Example with diagram-ATM, Library Management System etc

## 5. List out the components of Object-Oriented Analysis and Design.

- Applying UML and Patterns in OOA/D
- Assigning Responsibilities
- What Is Analysis and Design?
- What Is Object-Oriented Analysis and Design?
- An Example
- The UML

## **UNIT-II**

### **Designing objects with responsibilities**

#### 1. What is an initial domain object? (2 Marks)

An initial domain object is a class and it is chosen to be at or near the root of the containment or aggregation hierarchy of domain objects. This may be a facade controller, such as Register, or some other object considered to contain all or most other objects, such as a Store.

#### 2. List the ways to connect the UI Layer to the Domain Layer. (2 Marks) The ways are:

- An initializing routine (for example, a Java *main* method) creates both a UI and a domain object, and passes the domain object to the UI.
- A UI object retrieves the domain object from a well-known source, such as a factory object that is responsible for creating domain objects.

#### 3. Write a note on interface and domain layer responsibilities. (2 Marks)

The UI layer should not have any domain logic responsibilities. It should only be responsible for user interface tasks, such as updating widgets. The UI layer should forward requests for all domain-oriented tasks on to the domain layer, which is responsible for handling them.

#### 4. Define – Responsibilities and Methods (2 Marks)

The UML defines a responsibility as "a contract or obligation of a classifier".

Responsibilities are related to the obligations of an object in terms of its behaviour. Basically, these responsibilities are of the following two types:

- knowing
- doing

Doing responsibilities of an object include:

- doing something itself, such as creating an object or doing a calculation
- initiating action in other objects

-controlling and coordinating activities in other objects

Knowing responsibilities of an object include:

- knowing about private encapsulated data
- knowing about related objects
- knowing about things it can derive or calculate

**5. What is responsibility-driven design?(2 Marks)**

A popular way of thinking about the design of software objects and also larger scale components are in terms of responsibilities, roles, and collaborations. This is part of a larger approach called responsibility-driven design or RDD.

**6. What is meant by responsibilities? (2 Marks)**

The UML defines a responsibility as “a contract or obligation of a classifier”. Responsibilities are related to the obligations or behavior of an object in terms of its role.

**7. List the types of responsibilities. (2 Marks)**

The responsibilities are of the following two types: doing and knowing. Doing responsibilities of an object include:

- doing something itself, such as creating an object or doing a calculation
  - initiating action in other objects
  - controlling and coordinating activities in other objects
- Knowing responsibilities of an object include:
- knowing about private encapsulated data
  - knowing about related objects
  - knowing about things it can derive or calculate

**Creator**

**8. Who is creator? (2 Marks)**

Assign class B the responsibility to create an instance of class A if one or more of the following is true:

- B aggregates an object.
  - B contains an object.
  - B records instances of objects.
  - B closely uses objects.
  - B has the initializing data that will be passed to A when it is created (thus B is an Expert with respect to creating A).
  - B is a creator of an object.
- If more than one option applies, prefer a class B which aggregates or contains class A.

**9. Define – Creator (2 Marks)**

Creation of objects is one of the most common activities in an object-oriented system. Which class is responsible for creating objects is a fundamental property of the relationship between objects of particular classes.

**10. Define – Modular Design (2 Marks)**

Coupling and cohesion are old principles in software design; designing with objects does not imply ignoring well-established fundamentals. Another of these. Which is strongly related to coupling and cohesion? is to promote modular design.

**11. What are the advantages of factory objects? (2 Marks)** The advantages are:

- Separate the responsibility of complex creation into cohesive helper objects.
- Hide potentially complex creation logic.
- Allow introduction of performance-enhancing memory management strategies, such as object caching or recycling.

**12. List some Abstract for Factory (GoF) for Families of Related Objects. (2 Marks)** The Java POS implementations will be purchased from manufacturers.

**For example:**

```
// IBM's drivers  
com.ibm.pos.jpos.CashDrawer (implements jpos.CashDrawer)
```

```
com.ibm.pos.jpos.CoinDispenser (implements jpos.CoinDispenser)
// NCR's drivers
com.ncr.posdrivers.CashDrawer (implements jpos.CashDrawer)
com.ncr.posdrivers.CoinDispenser (implements jpos.CoinDispenser)
```

13. What is **meant** by abstract class abstract factory? (2 Marks)

A common variation on Abstract Factory is to create an abstract class factory that is accessed using the Singleton pattern, reads from a system property to decide which of its subclass factories to create, and then returns the appropriate subclass instance. This is used, for example, in the Java libraries with the *java.awt.Toolkit* class, which is an abstract class abstract factory for creating families of GUI widgets for different operating system and GUI subsystems

14. What is **meant** by fine-grained classes? (2 Marks)

Consider the creation of the Credit Card, Drivers License, and Check software objects. Our first impulse might be to record the data they hold simply in their related payment classes, and eliminate such fine-grained classes. However, it is usually a more profitable strategy to use them; they often end up providing useful behavior and being reusable. For example, the Credit Card is a natural Expert on telling you its credit company type (Visa, MasterCard, and so on). This behavior will turn out to be necessary for our application.

### Low Coupling

15. **Define – Low Coupling** (2 Marks)

Low Coupling is an evaluative pattern, which dictates how to assign responsibilities to support:

- Low dependency between classes;
- Low impact in a class of changes in other classes;
- High reuse potential;

16. **Define – Coupling** (A/M-11, M/J-12) (2 Marks) The degree to which components depend on one another. There are two types of coupling, "tight" and "loose". Loose coupling is desirable for good software engineering but tight coupling may be necessary for maximum performance. Coupling is increased when the data exchanged between components becomes larger or more complex. Coupling is the degree to which one class knows about another class. Let us consider two classes class **A** and class **B**. If class **A** knows class **B** through its interface only i.e., it interacts with class **B** through its API then class **A** and class **B** are said to be loosely coupled. If on the other hand class **A** apart from interacting class **B** by means of its interface also interacts through the non-interface stuff of class **B** then they are said to be tightly coupled.

### Applying GoF design patterns

17. **Define – Patterns** (2 Marks)

A pattern is a named problem/solution pair that can be applied in new context, with advice on how to apply it in novel situations and discussion of its trade-offs.

18. **List the GRASP Patterns.** (2 Marks)

The first five GRASP patterns are:

- . Information Expert
- . Creator
- . High Cohesion
- . Low Coupling
- . Controller

19. **What is meant by patterns?** (M/J-13, M/J-12) (2 Marks) Design patterns are supposed to provide a structure in which problems can be solved. When solving a real problem, you have to consider many tiny variations of a solution to that problem to see whether any fits a design pattern. In particular, you will probably need to generalise your problem, or its solution, in order to make a design pattern fit.

20. **What is meant by GRASP?** (M/J-13) (2 Marks)

GRASP (General Responsibility Assignment Software Patterns) provides guidance for assigning

responsibilities to classes and, to a limited extent, determining the classes that will be in a design in an object-oriented system. The different patterns and principles used in GRASP are: Controller, Creator, Indirection, Information Expert, High Cohesion, Low Coupling, Polymorphism, Protected Variations, and Pure Fabrication. All these patterns answer some software problem, and in almost every case these problems are common to almost every software development project.

21. **Write a note on patterns.** (N/D-11) (2 Marks) Design pattern identifies the key aspects of a common design structure that makes it useful for creating a reusable object oriented design. Furthermore, it identifies the participating classes and instances, their roles and collaborations, and the distribution of responsibilities. It describes when it applies, whether it can be applied in view of other design constraints and the consequences and tradeoffs of its use.

A pattern is an instructive information that captures the essential structure and insight of a successful family of proven solutions to a recurring problem that arises within a certain context and system of forces.

22. **Define – Object** (N/D-12) (2 Marks)

Objects are key to understanding object-oriented technology. Real-world objects share two characteristics: They all have state and behavior. Dogs have state (name, color, breed, hungry) and behaviour (barking, fetching, wagging tail). Bicycles also have state (current gear, current pedal cadence, current speed) and behavior (changing gear, changing pedal cadence, applying brakes). Identifying the state and behavior for real-world objects is a great way to begin thinking in terms of object-oriented programming.

### High Cohesion

23. **List out some scenarios that illustrate varying degrees of functional cohesion.** (2 Marks) Some scenarios that illustrate varying degrees of functional cohesion are,

- Very low cohesion
- Low cohesion
- High cohesion
- Moderate cohesion

24. **Define – High Cohesion** (2 Marks)

High Cohesion is an evaluative pattern that attempts to keep objects appropriately focused, manageable and understandable. High cohesion is generally used in support of Low Coupling. High cohesion means that the responsibilities of a given element are strongly related and highly focused. Breaking programs into classes and subsystems is an example of activities that increase the cohesive properties of a system.

25. **What is meant by high cohesion?** (N/D-12) (2 Marks)

Cohesion refers to the measure of how strongly-related the functions of a module. High cohesion refers to modules that have functions that are similar in many aspects.

The benefits of high cohesion are

1. Readability – (closely) related functions are contained in a single module
2. Maintainability – debugging tends to be contained in a single module
3. Reusability – classes that have concentrated functionalities are not polluted with useless functions

26. **Distinguish between coupling and cohesion.** (N/D-11) (2 Marks)

<b>Cohesion</b>	<b>Coupling</b>
Cohesion refers to what the class (or module) will do. Low cohesion would mean that the class does a great variety of actions and is not focused on what it should do. High cohesion would then mean that the class is focused on what it should be doing, i.e. only methods relating to the intention of the class.	It refers to how related are two classes / modules and how dependent they are on each other. Being low coupling would mean that changing something major in one class should not affect the other. High coupling would make your code difficult to make changes as well as to maintain it, as classes are coupled closely together, making a change could mean an entire system revamp.

High cohesion <i>within</i> modules	Low coupling <i>between</i> modules.
Increased cohesion and decreased coupling do lead to good software design.	The most effective method of decreasing coupling and increasing cohesion is <b>design by interface</b> .

### Controller

**27. What is controller? (2 Marks)**

The Controller pattern assigns the responsibility of dealing with system events to a non-UI class that represent the overall system or a use case scenario. A Controller object is a non-user interface object responsible for receiving or handling a system event.

### Information expert

**28. What is information expert? (2Marks)**

Information Expert is a principle used to determine where to delegate responsibilities. These responsibilities include methods, computed fields and so on. Using the principle of Information Expert a general approach to assigning responsibilities is to look at a given responsibility, determine the information needed to fulfil it, and then determine where that information is stored. Information Expert will lead to placing the responsibility on the class with the most information required to fulfil it.

### Adapter, singleton, factory and observer patterns.

**29. What is singleton pattern? (2 Marks)**

The singleton pattern is a design pattern used to implement the mathematical concept of a singleton, by restricting the instantiation of a class to one object. This is useful when exactly one object is needed to coordinate actions across the system.

**30. What is adapter pattern? (2 Marks)**

The adapter pattern is a design pattern that translates one interface for a class into a compatible interface. An adapter allows classes to work together that normally could not because of incompatible interfaces, by providing its interface to clients while using the original interface. The adapter is also responsible for transforming data into appropriate forms.

**31. What is facade pattern? (2 Marks)**

A facade is an object that provides a simplified interface to a larger body of code, such as a class library. A facade can:

- make a software library easier to use, understand and test, since the facade has convenient methods for common tasks;
- make code that uses the library more readable, for the same reason;
- reduce dependencies of outside code on the inner workings of a library, since most code uses the facade, thus allowing more flexibility in developing the system;
- wrap a poorly-designed collection of APIs with a single well-designed API (as per task needs).

**32. What is observer pattern? (2 Marks)**

The observer pattern (a subset of the publish/subscribe pattern) is a software design pattern in which an object, called the subject, maintains a list of its dependents, called observers, and notifies them automatically of any state changes, usually by calling one of their methods. It is mainly used to implement distributed event handling systems.

### PART –B

**1. Write briefly about elaboration and discuss the differences between Elaboration and Inception with examples.**

- Iteration 1 Requirements and Emphasis: Core OOA/D Skills
- Inception and Elaboration
- Planning the Next Iteration



## 2. Illustrate the concept of Domain model with examples. APRIL/MAY-2011

- Definitions
- Guidelines for creating domain model
- Examples

## 3. What is activity diagram? Explain about its applications briefly? APRIL/MAY-2011

- UML Activity Diagram Notation
- Guidelines for activity modeling
- Example –Next Gen Activity Diagram

## 4. Explain about Aggregations and compositions

- Definitions
- Identify Composition & Aggregations
- Example: the Next Gen Domain Model

### UNIT III

#### Elaboration

##### 1. What is an elaboration?

(M/J – 12) (2 Marks)

Elaboration is used to build the core architecture, resolve the high-risk elements, define most requirements, and estimate the overall schedule and resources.

##### 2. List the tasks performed in elaboration.

(2 Marks)

The tasks performed in elaboration are:

1. The core, risky software architecture is programmed and tested
2. The majority of requirements are discovered and stabilized
3. The major risks are mitigated or retired

##### 3. What are the key ideas and best practices that will manifest in elaboration?

(2 Marks)

The key ideas and best practices are:

1. Do a short time boxed risk-driven iterations
2. Start programming early
3. Adaptively design, implement, and test the core and risky parts of the architecture
4. Test early, often, realistically
5. Adapt based on feedback from tests, users, developers
6. Write most of the use cases and other requirements in detail, through a series of workshops, once per elaboration iteration

#### Domain Models

##### 4. What is domain model?

(A/M – 11) (2 Marks)

A domain model is a visual representation of conceptual classes or real-world objects in a domain of interest. They have also been called conceptual models, domain object models, and analysis object models.

##### 5. List the steps involved in creating a domain model.

(2 Marks)

The steps involved in creating a domain model are,

1. Find the conceptual classes
2. Draw them as classes in a UML class diagram
3. Add associations and attributes

##### 6. List the ways to illustrate a domain model.

(2 Marks)

Applying UML notation, a domain model is illustrated with a set of class diagrams in which no operations (method signatures) are defined. It provides a conceptual perspective. It shows the following,

1. Domain objects or conceptual classes

2. Associations between conceptual classes
3. Attributes of conceptual classes

**7. Why domain model is called as a "Visual Dictionary"?**

(2 Marks)

The information domain model illustrates could alternatively have been expressed in plain text. But it's easy to understand the terms and especially their relationships in a visual language, since our brains are good at understanding visual elements and line connections. Therefore, the domain model is a visual dictionary of the noteworthy abstractions, domain vocabulary, and information content of the domain.

**8. List the elements not suitable in a domain model.**

(2 Marks) The e

1. Software artifacts, such as a window or a database, unless the domain being modeled are of software concepts, such as a model of graphical user interfaces.
2. Responsibilities or methods.

**Finding conceptual classes and description classes**

**9. Define – Conceptual Classes**

(2

Marks)

The conceptual class is defined as an idea, thing, or object. More formally, a conceptual class may be considered in terms of its symbol, intension, and extension.

**10. Define – Description Class**

(2

Marks)

A description class is defined as information that describes something else. For example, a Product Description that records the price, picture, and text description of an Item.

**11. List the three strategies to find conceptual classes.**

(2 Marks) The thr

1. Reuse or modify existing models.
2. Use a category list.
3. Identify noun phrases

**Associations**

**12. What is an association?**

(2

Marks)

An association is a relationship between classes (more precisely, instances of those classes) that indicates some meaningful and interesting connection.

**13. Draw the UML notation for an association.**

(2

Marks)

Associations are defined as semantic relationship between two or more classifiers that involve connections among their instances.



**14. State the reason to avoid adding many associations.** (2 Marks)

We need to avoid adding too many associations to a domain model. In discrete mathematics, in a graph with n nodes, there can be associations to other nodes a potentially very large number. A domain model with 20 classes could have 190 associations' lines! Many lines on the diagram will obscure it with "visual noise." Therefore, be parsimonious about adding association lines.

**15. Write the format to name an association in UML.** (2 Marks)

Name in an association is based on a Class Name-Verb Phrase- Class Name format where the verb phrase creates a sequence that is readable and meaningful.

**16. What is multiplicity?** (2 Marks)

Multiplicity defines how many instances of class A can be associated with one instance of a class B.

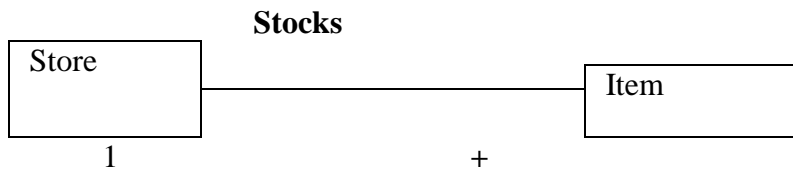

**17. What are association role names?** (2 Marks) Each end of an association has a role name. The role name is a name for the role played by the object at the end of the association. The role name is a name for the role played by the object at the end of the association. The role name is a name for the role played by the object at the end of the association.

1. Name
2. Multiplicity

A role name identifies an end of an association and ideally describes the role played by objects in the association.

**18. What is qualified association?** (2 Marks)

A qualifier may be used in an association; it distinguishes the set of objects at the far end of the association based on the qualifier value. An association with a qualifier is a qualified association. For example, ProductDescriptions may be distinguished in a ProductCatalog by their itemID.

### Attributes

**19. What is an attribute?** (2 Marks)

An attribute is a logical data value of an object. It is useful to identify those attributes of conceptual classes that are needed to satisfy the information requirements of the current scenarios under development.

**20. What is a derived attributes?** (2 Marks)

The derived attribute is an attribute whose value is calculated from some other attribute. The total attribute in the Sale can be calculated or derived from the information in the SalesLineItems.

### **Domain Model Refinement**

**21. How does domain model is further refined after the first iteration?** (2 Marks)

Generalization and specializations are fundamental concepts in domain modeling. Conceptual class hierarchies are often inspiration for software class hierarchies that exploits inheritance and reduce duplication of code.

Packages are a way to organize large domain models into smaller units.

Domain model is further refined with Generalization, Specialization, Association classes, Time intervals, Composition and packages, usage of subclasses.

**22. State the way to develop a domain model incrementally.** (2 Marks)

The domain model is incrementally developed by considering concepts in the requirements for this iteration.

**23. What is generalization?** (2 Marks)

Generalization is the activity of identifying commonality among concepts and defining superclass (general concept) and subclass (specialized concept) relationships.

**24. Differentiate single inheritance from multiple inheritances.** (N/D –12) (2 Marks)

In single inheritance one class inherits its state (attributes) and behavior from exactly one super class. When one class inherits its state (attributes) and behavior from more than one super class, it is referred to as multiple inheritances.

**25. What is the need for packages?** (2 Marks)

A domain model can easily grow large enough that it is desirable to factor it into packages of strongly related concepts, as an aid to comprehension and parallel analysis work in which different people do domain analysis within different sub-domains.

Following Sections illustrate a package structure for the UP Domain Model:

1. UML Package Notation
2. Ownership and References
3. Package Dependencies

**26. Draw the UML Package with an example.** (2 Marks)

A UML package is shown as tabbed folder as shown above. Subordinate packages may be shown within it. The package name is within the tab if the package depicts its elements; otherwise, it is centered within the folder itself.

**27. What is package dependency?** (2 Marks)

If a model element is in some way dependent on another,

1. The dependency may be shown with a dependency relationship
2. Depicted with Arrowed Line
3. A package dependency indicates elements of the dependent package know about or are coupled to elements in the target package

Example:

The sales package has a dependency on the Core Elements package.

### **Finding conceptual class hierarchies**

**28. What are the uses of defining conceptual super classes and subclasses?** (2 Marks)

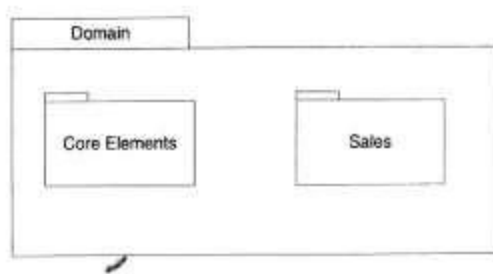

Defining is valuable to identify conceptual super and subclasses, it is useful to clearly and precisely understand generalization, super classes, and subclasses in terms of class definition and class sets.

**29. State the role of conceptual subclass and super classes in set membership.** (2 Marks)

Conceptual subclasses and super classes are related in terms of set membership. By definition, all members of a conceptual subclass set are members of their super class set. For example, in terms of set membership, all instances of the set CreditPayment are also members of the set Payment. This is shown in the Venn diagram shown below.

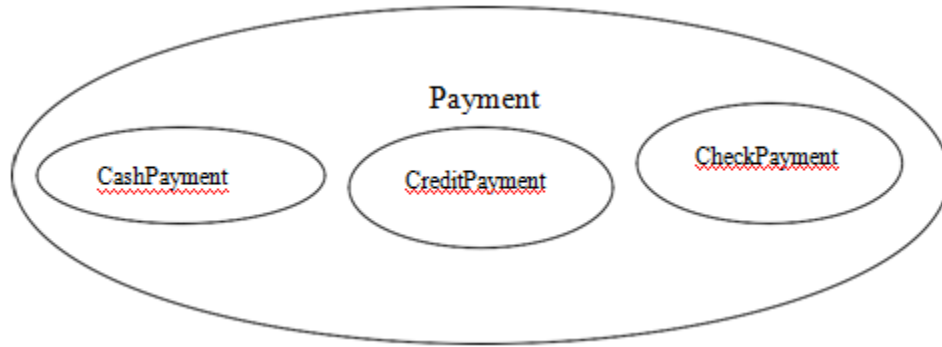

**30. What is 100% rule?  
(2 Marks)**

100% of the conceptual Super class's definition should be applicable to the subclass. The subclass must conform to 100% of the Super class's attributes and associations.

**31. Write the guidelines followed in defining a super class.**

(2 Marks) The g

Create a super class in a generalization relationship to subclasses when :

1. The potential conceptual subclasses represent variations of a similar concept
2. The subclasses will confirm to the 100% and Is-A rules
3. All subclasses have the same attribute that can be factored out and expressed in the super class
4. All subclasses have the same association that can be factored out and related to the super class

**32. What are the strong motivations to partition a conceptual class with subclasses?**

(2 Marks) The following are the strong motivations to partition a class into subclasses :

Create a conceptual subclass of a super class when :

1. The subclass has additional attributes of interest
2. The subclass has additional associations of interest
3. The subclass concept is operated on, handled, reacted-to, or manipulated differently than the super class or other subclasses

**Aggregation and  
Composition**

**33. What is aggregation?  
(2 Marks)**

(A/M – 11, M/J – 12)

Aggregation is a vague kind of association in the UML that loosely suggests whole-part relationships (as do many ordinary associations). It has no meaningful distinct semantics in the UML versus a plain association, but the term is defined in the UML.

**34. What is composition?  
Marks)**

(A/M – 11, M/J – 12) (2

Composition, also known as composite aggregation, is a strong kind of whole-part

aggregation and is useful to show in some models. A composition relationship implies that 1) an instance of the part belongs to only one composite instance at a time, 2) the part must always belong to a composite and 3) the composite is responsible for the creation and deletion of its parts either by itself creating/deleting the parts, or by collaborating with other objects.

**35. What are the benefits of showing composition?** (2

Marks)

Showing composition clarifies the domain constraints regarding the eligible existence of the part independent of the whole. In composite aggregation, the part may not exist outside of the lifetime of the whole.

1. During design work, this has an impact on the create-delete dependencies between the whole and part software classes and database elements (in terms of referential integrity and cascading delete paths)
2. It consists in the identification of a creator (the composite) using the GRASP Creator Pattern.
3. Operations – such as copy and delete – applied to the whole often propagate to the parts.

**Inception -Use case Modeling**

**36. Define – Inception** (2

Marks)

The inception is defined as an envision of product scope, vision, and business case.

The purpose of inception stage is not to define all the requirements. The Up is not the waterfall and the first phase inception is not the time to do all requirements or creates believable estimates or plans. That happens during elaboration.

**37. State the intent of inception phase.**

(  
2 Marks) The intent of inception is to establish some initial common vision for the objectives of the project, determine if it is feasible, and decide if it is worth some serious investigation in elaboration. It can be brief.

**38. Define – Requirements** (2

Marks)

Requirements are capabilities and conditions, to which the system and more broadly, the project must conform,

- 1) The UP promotes a set of best practices, one of which is to manage requirements.
- 2) In the context of changing and unclear stakeholder's wishes – Managing requirements means a systematic approach to finding, documenting, organizing, and tracking the changing requirements of a system.

A prime challenge of requirements analysis is to find, communicate, and remember (To write down) what is really needed, in a form that clearly speaks to the client and development team members.

**39. List the types and categories of requirements.**

(2 Marks) In the

- 2) Functional - features, capabilities, security.
- 3) Usability - human factors, help, documentation.
- 4) Reliability - frequency of failure, recoverability, predictability.
- 5) Performance - response times, throughput, accuracy, availability, resource usage.
- 6) Supportability - adaptability, maintainability, internationalization, configurability.

**40. List the key requirements of artifacts.**

(2 Marks) The K

- 1) Use Case Model - A set of typical scenarios of using a system. There are primarily for functional (behavioural) requirements.
- 2) Supplementary Specification - Basically, everything not in the use cases. This artifact is primarily for all non-functional requirements, such as performance or licensing. It is also the place to record functional features not expressed (or expressible) as use cases; for example, a report generation.
- 3) Glossary - In its simplest form, the Glossary defines noteworthy terms. It also encompasses the concept of the data dictionary, which records requirements related to data, such as validation rules, acceptable values, and so forth. The Glossary can detail any element: an attribute of an object, a parameter of an operation call, a report layout, and so forth.
- 4) Vision - Summarizes high-level requirements that are elaborated in the Use-Case Model and Supplementary Specification, and summarizes the business case for the project.
- 5) Business Rules - Business rules (also called Domain Rules) typically describe requirements or policies that transcend one software project they are required in the domain or business, and many applications may need to conform to them. An excellent example is government tax laws. Domain rule details may be recorded in the Supplementary Specification, but because they are usually more enduring and applicable than for one software project, placing them in a central Business Rules artifact (shared by all analysts of the company) makes for better reuse of the analysis effort.

**41. Define -- Actors, Scenarios and Use Cases**

(A/M-08)

(2 Marks)

An actor is something with behaviour, such as a person (identified by role), computer system, or organization; for example, a cashier.

A scenario is a specific sequence of actions and interactions between actors and the system; it is also called a use case instance. It is one particular story of using a system, or one path through the use case; for example, the scenario of successfully purchasing items with cash, or the scenario of failing to purchase items because of a credit payment denial.

A use case is a collection of related success and failure scenarios that describe an actor using a system to support a goal.

**42. Define – Use Case Modelling**

(2 Marks)

Use-Case Model is the set of all written use cases; it is a model of the system's



functionality and environment. Use cases are text documents, not diagrams, and use-case modeling is primarily an act of writing text, not drawing diagrams.

The Use-Case Model is not the only requirement artifact in the UP. There are also the Supplementary Specification, Glossary, Vision, and Business Rules. These are all useful for requirements analysis, but secondary at this point.

The Use-Case Model may optionally include a UML use case diagram to show the names of use cases and actors, and their relationships. This gives a nice context diagram of a system and its environment. It also provides a quick way to list the use cases by name.

**43. List the three kinds of actors.**

(2 Marks)

Actors are roles played not only by people, but by organizations, software, and machines. The three kinds of external actors in relation to the SuD are,

- 1) Primary actor has user goals fulfilled through using services of the SuD. For example, the cashier.
- 2) Supporting actor provides a service (for example, information) to the SuD. The automated payment authorization service is an example. Often a computer system, but could be an organization or person.
- 3) Offstage actor has an interest in the behaviour of the use case, but is not primary or supporting; for example, a government tax agency.

**44. What are the preconditions and post conditions of scenarios?**

(2 Marks) Preconditions state what must always be true before a scenario is begun in the use case.

Preconditions are not tested within the use case; rather, they are conditions that are assumed to be true. Typically, a precondition implies a scenario of another use case, such as logging in, that has successfully completed.

Success guarantees (or post conditions) state what must be true on successful completion of the use case either the main success scenario or some alternate path. The guarantee should meet the needs of all stakeholders.

**EXAMPLE:**

Preconditions: Cashier is identified and authenticated.

Success Guarantee (Post conditions): Sale is saved. Tax is correctly calculated. Accounting and Inventory are updated. Commissions recorded. Receipt is generated.

**45. List the steps to find use cases.**

(N/D-

12) (2 Marks) Use cases are defined to satisfy the goals of the primary actors.

Hence, the basic procedures are,

- 1) Choose the system boundary
- 2) Identify the primary actors those that have goals fulfilled through using services of the system.
- 3) Identify the goals for each primary actor.
- 4) Define use cases that satisfy user goals; name them according to their goal.

## **PART- B**

### **1. How to Adding New SSDs and Contracts?**

- New System Sequence Diagrams
- New System Operations
- New System Operation Contracts

### **2. Explain about Interaction Diagram Notation? APRIL/MAY-2011**

- Sequence and Collaboration Diagrams
- Collaboration Diagram
- Sequence Diagram
- Common Interaction Diagram Notation
- Basic Collaboration Diagram
- Notation
- Basic Sequence Diagram Notation

### **3. Design the Model and Creating Design Class Diagrams.**

- When to Create DCDs
- Example DCD
- DCD and UP
- Domain Model vs. Design Model Classes
- DCDs, Drawing, and CASE Tools
- DCDs within the UP

### **4. What are concepts involved in domain refinement?**

- Generalization
- Defining Conceptual Super classes and Subclasses
- Class Hierarchies and Inheritance
- Aggregation and Composition
- Examples

### **5. Illustrate with an example, the relationship between sequence diagram and use cases. APIRAL/MAY-2011**

## **UNIT IV**

### **System Sequence Diagram**

#### **1. What is the system sequence diagram? Mention its use.**

(A/M-11) (M/J-12)(N/D-11) (2Marks)

A system sequence diagram (SSD) is a picture that shows, for a particular scenario of a use case, the events that external actors generate their order, and inter-system events. All systems are treated as a black box; the emphasis of the diagram is events that cross the system boundary from actors to systems.

#### **2. What is meant by sequence number in UML? Where and for what it is used?**

(N/D-11) (2 Marks)

Sequence number can be of:

- Automatic - Sequence numbers of messages will be updated automatically after you moved the messages, and you cannot specify custom sequence number to messages.
- Manual - Sequence numbers of messages will not be updated even after you moved the messages, and you can specify custom sequence number to messages.

Uses:

- Trace external interactions with the software
- Plan the internal behavior of the application
- Study the software structure
- View the system architecture
- Trace behavior down to physical components

**3. List the relationships used in class diagram.**

(A/M-11)

(2 Marks)

Category	Function
Activity edges	Represent the flow between activities
Associations	Indicate that instances of one model element are connected to instances of another model element
Dependencies	Indicate that a change to one model element can affect another model element
Generalizations	Indicate that one model element is a specialization of another model element
Realizations	Indicate that one model element provides a specification that another model element implements
Transitions	Represent changes in state

**4. What is meant by system behavior?**

(2 Marks) System

Part of that description is a system sequence diagram. Other parts include the Use cases, and system contracts.

**5. What is meant by inter-system SSDs?**

(2 Marks) SSDs

POS and the external credit payment authorizer. However, this is deferred until a later iteration in the case study, since this iteration does not include remote systems collaboration.

**6. Define – System Events, System Boundary**

(2 Marks)

To identify system events, it is necessary to be clear on the choice of system boundary, as discussed in the prior chapter on use cases. For the purposes of software development, the system boundary is usually chosen to be the software system itself; in this context, a system event is an external event that directly stimulates the software.

**7. Write short note on naming system events and operations.**

(2 Marks)

System events (and their associated system operations) should be expressed at the level of intent rather than in terms of the physical input medium or interface widget level.

It also improves clarity to start the name of a system event with a verb Thus "enter item" is better than "scan" (that is, laser scan) because it captures the intent of the operation while remaining abstract and noncommittal with respect to design choices about what interface is used to capture the system event.

**Logical architecture and UML Package Diagram**

**8. Define – Package**

(M/J- 12) (2

Marks)

A package groups and manages the modelling elements, such as classes, their associations, and their structures. Packages themselves may be nested within other packages. A package may contain both other packages and ordinary model elements. The entire system description can be thought of as a single high-level sub-system package with everything else init. All kinds of UML model elements and diagrams can be organized into packages.

**9. What are interactive diagrams? List the components involved in interactive diagrams.**

(N/D-12)

(2 Marks)

Interaction diagrams are diagrams that describe how groups of objects collaborate to get the job done interaction diagrams capture the behavior of the single use case, showing the pattern of interaction among objects.

There are two kinds of interaction models,

- Sequence Diagram
- Collaboration Diagram.

**10. What are the uses of UML component diagram?**

(A/M-

10)(2 Marks) The uses of UML component diagram are:

- Model the components of a system.
- Model database schema.
- Model executables of an application.
- Model system's source code.

**11. What is Software Architecture?**

(2

Marks)

An architecture is the set of significant decisions about the organization of a software system, the selection of the structural elements and their interfaces by which the system is composed, together with their behavior as specified in the collaborations among those elements, the composition of these structural and behavioral elements into progressively larger subsystems, and the architectural style that guides this organization these elements and their interfaces, their collaborations, and their composition.

### **Logical Architecture Refinement**

**12. What is a layer?** (2

Marks)

A layer is a very coarse-grained grouping of classes, packages, or subsystems that has cohesive responsibility for a major aspect of the system. Also, layers are organized such that "higher" layers (such as the UI layer) call upon services of "lower" layers, but not normally vice versa.

**13. What are the UML Operations and method?** (2

Marks)

A UML operation is a declaration, with a name, parameters, return type, exceptions list, and possibly a set of constraints of pre-and post-conditions. But, it isn't an implementation rather, methods are implementations.

A UML method is the implementation of an operation; if constraints are defined, the method must satisfy them. A method may be illustrated several ways, including:

- In interaction diagrams, by the details and sequence of messages
- In class diagrams, with a UML note symbol stereotyped with «method»

**14. What is the logical architecture?**

(2 Marks)

The logical architecture is the large-scale organization of the software classes into packages (or namespaces), subsystems, and layers. It's called the logical architecture because there's no decision about how these elements are deployed across different operating system processes or across physical computers in a network.

**15. Define – Classifier**

(2 Marks)

A UML classifier is a model element that describes behavioral and structure features. Classifiers can also be specialized. They are a generalization of many of the elements of the UML, including classes, interfaces, use cases, and actors. In class diagrams, the two most common classifiers are regular classes and interfaces.

**16. What are the connection between SSDs, system operations, and layers?** (2

Marks)

The SSDs illustrate these system operations, but hide the specific UI objects. Nevertheless, normally it will be objects in the UI layer of the system that capture these system operation requests, usually with a rich client GUI or Web page.

## UML Class Diagrams

### **17. What are UML properties and property strings?**

(2 Marks)

In the UML, a property is a named value denoting a characteristic of an element. A property has semantic impact. Some properties are predefined in the UML, such as visibility a property of an operation. Others can be user-defined.

Properties of elements may be presented in many ways, but a textual approach is to use the UML property string {name1=value1, name2=value2} format, such as {abstract, visibility=public}. Some properties are shown without a value, such as {abstract}; this usually implies a boolean property, shorthand for {abstract=true}. Note that {abstract} is both an example of a constraint and a property string.

### **18. What is an association class?**

(2 Marks)

An association class allows you treat an association itself as a class, and model it with attributes, operations, and other features. For example, if a Company employs many Persons, modelled with an Employs association, you can model the association itself as the Employment class, with attributes such as startDate.

### **19. List the relationships used in class diagram?**

(M/J -

12)(2 Marks) The following are the relationships used in class diagram:

1. Generalization(class to class)
2. Association (object to object)
3. Aggregation (object to object)
4. Composition (object to object)

### **20. What is design class diagram (DCD)?**

(2 Marks)

It can explored, the same UML diagram can be used in multiple perspectives (Figure below). In a conceptual perspective the class diagram can be used to visualize a domain model. A unique term to clarify when the class diagram is used in software or design perspective is called design class diagram (DCD), and all DCDs form part of the Design Model.

## Package diagrams

### **21. How to show methods in class diagrams?**

(2 Marks)

A UML method is the implementation of an operation; if constraints are defined, the method must satisfy them. A method may be illustrated several ways, including: in interaction diagrams, by the details and sequence of messages in class diagrams, with a UML note symbol stereotyped with «method».

### **22. Define – Keywords, Stereotype, Profiles and Tags**

(2 Marks)

Keywords, stereotypes are shown with guillemot's symbols, such as «authorship».

But, they are not keywords, which can be confusing. A stereotype represents a refinement of an existing modelling concept and is defined within a UML profile—informally, a collection of related stereotypes, tags, and constraints to specialize the use of the UML for a specific domain or platform, such as a UML profile for project management or for data modelling. The UML predefines many stereotypes, such as

«destroy» (used on sequence diagrams), and also allows user-defined ones. Thus, stereotypes provide an extension mechanism in the UML.

### UML Interaction Diagrams

**23. What is the use of interaction diagram?** (M/J – 13)

(2 Marks) The term interaction diagram is a generalization of two more specialized UML diagram types; both can be used to express similar message interactions:

- Collaboration diagrams
- Sequence diagrams

**24. What is meant by link?**

(2 Marks)

A link is a connection path between two objects; it indicates some form of navigation and visibility between the objects is possible. More formally, a link is an instance of an association. For example, there is a link or path of navigation from a Register to a Sale, along which messages may flow, such as the make 2 Payment message.

Each message between objects is represented with a message expression and small arrow indicating the direction of the message. Many messages may flow along this link. A sequence number is added to show the sequential order of messages in the current thread of control.

**25. What is an instance?** (2 Marks)

Any message can be used to create an instance, but there is a convention in the UML to use a message named *create* for this purpose. If another (perhaps less obvious) message name is used, the message may be annotated with a special feature called a UML stereotype, like so: «create».

The create message may include parameters, indicating the passing of initial values. This indicates, for example, a constructor call with parameters in Java.

### PART- B

**1. Explain Grasp: designing objects with responsibilities.**

- Responsibilities and Methods
- Responsibilities and Interaction Diagrams
- Patterns

**2. Explain GRASP: Patterns of General Principles in Assigning Responsibilities.**

**APIRAL/MAY-2011**

- The UML Class Diagram Notation
- Information Expert (or Expert)
- Creator
- low coupling
- high cohesion
- controller
- object design and CRC CARDS

**3. How to Determining the Visibility of the Design Model?**

- Visibility between Objects
- Visibility

**4. Explain about Patterns for Assigning Responsibilities.**

- Polymorphism
- Pure Fabrication
- Indirection
- Protected Variations

**5. Designing the Use-Case Realizations with GoF Design Patterns. APRIL/MAY-2011**

- Analysis" Discoveries during Design: Domain Model
- Factory
- Singleton
- Conclusion of the External Services with Varying Interfaces Problem 3
- Strategy
- Composite
- Façade

**UNIT V**

**Mappi**

**ng**

**Design**

**to**

**Code**

**1. List the steps involved in mapping design to code.**

(2 Marks)

**1. Class and interface definitions**

The required visibility and associations between classes are indicated by the interaction diagrams.

**2. Method definitions**

A method body implementation may be shown in a UML note box. It should be placed with in braces, it is semantic influence. The syntax may be pseudo-code, or any language.

It is common to exclude the method signature (public void ...), but it is legal to include it.

**2. What is State-Independent and State-Dependent Objects?**

(2 Marks)

If an object always responds the same way to an event, then it is considered



state independent (or modeless) with respect to that event.  
If for all events of interest, an object always reacts the same way, it is a state-independent object. By contrast, state-dependent objects react differently to events depending on their state or mode.

### **3. Write the attribute presentation suggested by UML?**

(2 Marks)

OCL can be used during the design phase to define the class attributes .The following is the attribute presentation suggested by UML.

Visibility name: type –expression-initial-value where visibility is

+ public visibility

# protected visibility

- private visibility

Type – expression is language dependent specification .Initial – value is language dependent expression for the initial value of a newly created object.

### **4. What are the three relationships that can be shown in UML diagram? Define them.**

(2 Marks)

1. Association how are objects associated? This information will guide us in designing classes.
2. Super-Sub Structure How are objects organized into super classes and sub classes? This information provides us the direction of inheritance.
3. Aggregation and a part of Structure what is the composition of complex classes? This information guides as in defining mechanisms that properly manage object within object.

### **5. Define – Database Models**

(2 Marks)

A database model is a collection of logical constructs representing the data structure and data relationship within the database.

Database models is of two categories

1. Conceptual model

2. Implementation model

Conceptual Model: Focuses on logical nature of data. It deals with what is represented in the database.

Implementation Model: is concerned with how it is represented.

### **6. Define – Testing**

(2 Marks)

- Testing is generally described as a group of procedures carried out to evaluate some aspect of a piece of software.
- Testing can be described as a process used for revealing defects in software and for establishing that the software has attained a specified degree of quality with respect to selected attributes.

### **7. State some of the important test related issues.**

(2 Marks)

- There is a demand for software of high quality with low defects;

- Process is important in the software engineering discipline;
- Software testing is an important software development sub process;
- Existing software evaluation and improvement models have not adequately addressed testing issues.

**8. What are the two major goals considered for integrated testing?** (2 Marks)

- to detect defects that occur on the interfaces of units;
- to assemble the individual units into working subsystems and finally a complete system that is ready for system test.

**9. List the issues of class testing.** (2 Marks)

Issue1: Adequately testing classes

Issue2: Observation of object states and state changes. Issue3: The retesting of classes-I

Issue4: The retesting of classes-II

**10. What are the challenges of class testing?** (2 Marks) OO

**Encapsulation:**

Difficult to obtain a snapshot of a class without building extra methods which display the classes' state

**Inheritance and polymorphism:**

Each new context of use (subclass) requires re-testing because a method may be implemented differently (polymorphism).

Other unaltered methods within the subclass may use the redefined method and need to be tested.

**11. How is class testing different from conventional testing?** (2 Marks)

Conventional testing focuses on input-process-output, whereas class testing focuses on each method, then designing sequences of methods to exercise states of a class.

**12. Write the impact of OO programming on testing.** (2 Marks)

When an operation is invoked, it may be hard to tell exactly what code gets exercised. It can be hard to determine the exact type or class of a parameter. OO operations are smaller, more time needed for integration. So integration faults become more plausible.

**13. List the class testing techniques.** (2 Marks)

- State transition testing
- Transaction flow testing
- Exception testing

**14. What are the three different incremental strategies of integration testing?** (2 Marks)

- Thread-based testing
- Use-based testing
- Cluster testing

**15. List the types of errors found during integration testing.**

(2 Marks)

- Messaging errors
- User interface errors

**16. What are the challenges of GUI testing?**

(2 Marks)

- GUI test automation is harder than API test automation
- Documentation; GUIs are slower than APIs
- Observing visible GUI state is difficult
- Observing invisible GUI state is tricky almost impossible
- Controlling GUI actions is difficult

**17. List the automated GUI testing tools.**

(2 Marks)

- Capture/Replay testing tools
- Random testing
- Unit testing
- Model-Based testing

**Unit-V**  
**PART- B**

**1. Explain UML State Machine Diagrams and Modeling.**

- Definition
- How to apply
- Example
- Process

**2. What is the operation of contracts works.**

- Contracts
- Contract Sections
- Post Conditions
- Guidelines: Contracts
- Next Gen POS Example
- Changes to the Domain Model
- Contracts, Operations, and the UML
- Operation Contracts Within the UP

**3. Explain the operation of Mapping Designs to Code. APRIL/MAY-2011**

- Programming and the Development Process
- Mapping Designs to Code
- Creating Class Definitions from DCDs
- Creating Methods from Interaction Diagrams
- Container/Collection Classes in Code
- Exceptions and Error Handling
- Defining the Sale--makeLineItem Method
- Order of Implementation
- Test-First Programming

**4. What is operation of UML Deployment and Component Diagram? Draw the diagram for a banking application. APRIL/MAY-2011**

-Deployment Diagram

-Component Diagram

**DIGITAL SIGNAL PROCESSING**  
**UNIT 1 – SIGNALS AND SYSTEMS**  
**Part A**

**1. What is a continuous and discrete time signal?**

**Continuous time signal:** A signal  $x(t)$  is said to be continuous if it is defined for all time  $t$ . Continuous time signal arise naturally when a physical waveform such as acoustics wave or light wave is converted into a electrical signal.

**Discrete time signal:** A discrete time signal is defined only at discrete instants of time. The independent variable has discrete values only, which are uniformly spaced. A discrete time signal is often derived from the continuous time signal by sampling it at a uniform rate.

**2. Give the classification of signals?**

- x Continuous-time and discrete time signals
- x Even and odd signals
- x Periodic signals and non-periodic signals
- x Deterministic signal and Random signal
- x Energy and Power signal

**3. What are the types of systems?**

Continuous time and discrete time systems

- x Linear and Non-linear systems
- x Causal and Non-causal systems
- x Static and Dynamic systems
- x Time varying and time in-varying systems
- x Distributive parameters and Lumped parameters systems
- x Stable and Un-stable systems.

#### 4. What are even and odd signals?

**Even signal:** continuous time signal  $x(t)$  is said to be even if it satisfies the condition  $x(t)=x(-t)$  for all values of  $t$ .

**Odd signal:** the signal  $x(t)$  is said to be odd if it satisfies the condition  $x(-t)=-x(t)$  for all  $t$ . In other words even signal is symmetric about the time origin or the vertical axis, but odd signals are anti-symmetric about the vertical axis.

#### 5. What are deterministic and random signals?

**Deterministic Signal:** deterministic signal is a signal about which there is no certainty with respect to its value at any time. Accordingly, we find that deterministic signals may be modeled as completely specified functions of time.

**Random signal:** random signal is a signal about which there is uncertainty before its actual occurrence. (e.g.) The noise developed in a television or radio amplifier is an example for random signal.

#### 6. What are energy and power signal?

**Energy signal:** Signal is referred as an energy signal, if and only if the total energy of the signal satisfies the condition  $0 < E < \infty$ .

**Power signal:** Signal is said to be power signal if it satisfies the condition  $0 < P < \infty$ .

#### 7. What are elementary signals and name them?

The elementary signals serve as a building block for the construction of more complex signals. They are also important in their own right, in that they may be used to model many physical signals that occur in nature.

There are five elementary signals. They are as follows

- x Unit step function
- x Unit impulse function
- x Ramp function
- x Exponential function
- x Sinusoidal function

## 8. What are time invariant systems?

A system is said to be **time invariant** system if a time delay or advance of the input signal leads to an identical shift in the output signal. This implies that a time invariant system responds identically no matter when the input signal is applied. It also satisfies the condition

$$R\{x(n-k)\} = y(n-k).$$

## 9. What do you mean by periodic and non-periodic signals?

A signal is said to be periodic if  $x(n+N) = x(n)$ , Where  $N$  is the time period. A signal is said to be non-periodic if  $x(n+N) = -x(n)$ .

## 10. Define time variant and time invariant system.

A system is called **time invariant** if its output, input characteristics does not change with time. A system is called **time variant** if its input, output characteristics changes with time.

## 11. Define linear and non-linear system.

Linear system is one which satisfies superposition principle. Superposition principle:

The response of a system to a weighted sum of signals be equal to the corresponding weighted sum of responses of system to each of individual input signal.

$$\text{i.e., } T[a_1x_1(n)+a_2x_2(n)] = a_1T[x_1(n)] + a_2T[x_2(n)]$$

A system, which does not satisfy superposition principle, is known as non-linear system.

## 12. Define causal and non-causal system.

The system is said to be **causal** if the output of the system at any time 'n' depends only on present and past inputs but does not depend on the future inputs.  
e.g.:-  $y(n) = x(n) - x(n-1)$

A system is said to be **non-causal** if a system does not satisfy the above definition.

**13. What are the steps involved in calculating convolution sum?**

The steps involved in calculating sum are

- x Folding
- x Shifting
- x Multiplication
- x Summation

**14. Define causal LTI system.**

The LTI system is said to be causal if  $h(n) = 0$  for  $n < 0$

**15. Define stable LTI system.**

The LTI system is said to be stable if its impulse response is absolutely summable.

**16. What are the properties of convolution sum?**

The properties of convolution sum are

- x Commutative property

The commutative law can be expressed as  $x(n) * h(n) = h(n) * x(n)$

- x Associative law

The associative law can be expressed as  $[x(n) * h_1(n)] * h_2(n) = x(n) * [h_1(n) * h_2(n)]$  Where  $x(n)$  – input,  $h_1(n)$ ,  $h_2(n)$  - impulse response

- x Distributive law

The distributive law can be expressed as

$$x(n) * [h_1(n) + h_2(n)] = x(n) * h_1(n) + x(n) * h_2(n)$$

**17. Define Region of convergence**

The region of convergence (ROC) of  $X(Z)$  is the set of all values of  $Z$  for which  $X(Z)$  attain final value.

### 18. State properties of ROC

- x The ROC does not contain any poles.
- x When  $x(n)$  is of finite duration then ROC is entire Z-plane except  $Z = 0$  or  $Z = \infty$
- x If  $X(Z)$  is causal, then ROC includes  $Z = \infty$
- x If  $X(Z)$  is non-casual, then ROC includes  $Z = 0$

### 19. Continuous time and Discrete time signals.

S. No	Continuous Time (CTS)	Discrete time (DTS)
1	This signal can be defined at any time instance & they can take all values in the continuous interval(a, b) where a can be $-\infty$ & b can be $\infty$	This signal can be defined only at certain specific values of time. These time instance need not be equidistant but in practice they are usually takes at equally spaced intervals.
2	These are described by differential equations.	These are described by difference equation.
3	This signal is denoted by $x(t)$ .	These signals are denoted by $x(n)$ or

### 20. Analog and digital signal

S. No	Analog signal	Digital signal
1	These are basically continuous time & continuous amplitude signals.	These are basically discrete time signals & discrete amplitude signals. These signals are basically obtained by sampling & quantization process.
2	ECG signals, Speech signal, Television signal etc. All the signals generated from various sources in nature are analog.	All signal representation in computers and digital signal processors are digital.

### PART – B (16 Marks)

1. Explain in detail about the classification of discrete time systems. (16)
2. (a) Describe the different types of discrete time signal representation. (6)
  - (b) Define energy and power signals. Determine whether a discrete time unit step signal  $x(n) = u(n)$  is an energy signal or a power signal. (10)
3. (a) Give the various representation of the given discrete time signal  $x(n) = \{-1, 2, 1, -2, 3\}$  in



Graphical, Tabular, Sequence, Functional and Shifted functional. (10)

(b) Give the classification of signals and explain it. (6)

4. (a) Draw and explain the following sequences:

- i) Unit sample sequence
- ii) Unit step sequence
- iii) Unit ramp sequence
- iv) Sinusoidal sequence and v) Real exponential sequence (10)

(b) Determine if the system described by the following equations are causal or noncausal

i)  $y(n) = x(n) + (1 / (x(n-1)))$

ii)  $y(n) = x(n^2)$  (6)

5. Determine the values of power and energy of the following signals. Find whether the signals are power, energy or neither energy nor power signals.

i)  $x(n) = (1/3)^n u(n)$

ii)  $x(n) = e^{j((\pi/2)n + (\pi/4))}$

iii)  $x(n) = \sin(\pi/4)n$

iv)  $x(n) = e^{2n} u(n)$  (16)

6. (a) Determine if the following systems are time-invariant or time-variant

i)  $y(n) = x(n) + x(n-1)$

ii)  $y(n) = x(-n)$  (4)

(b) Determine if the system described by the following input-output equations are linear or non-linear.

i)  $y(n) = x(n) + (1 / (x(n-1)))$

ii)  $y(n) = x^2(n)$

iii)  $y(n) = nx(n)$  (12)

7. Test if the following systems are stable or not.

i)  $y(n) = \cos x(n)$

ii)  $y(n) = ax(n)$

iii)  $y(n) = x(n) e^n$

iv)  $y(n) = ax(n)$  (16)

8. (a) Explain the principle of operation of analog to digital conversion with a neat

diagram. (8)

(b) Explain the significance of Nyquist rate and aliasing during the sampling of continuous

time signals.

(8)

9. (a) List the merits and demerits of Digital signal processing. (8)

(b) Write short notes about the applications of DSP. (8)

10. (a) Find the convolution of the following sequences

i)  $x(n)=u(n)$   $h(n)=u(n-3)$

ii)  $x(n)=\{1,2,-1,1\}$   $h(n)=\{1,0,1,1\}$  (8)

(b) Determine the response of the causal system  $y(n)-y(n-1)=x(n)+x(n-1)$  to inputs  $x(n)=u(n)$  and  $x(n)=2^{-n}u(n)$ . (8)

11. (a) Determine the solution of the difference equation

$y(n) = 5/6 y(n-1) - 1/6 y(n-2) + x(n)$  for  $x(n) = 2n u(n)$  (8)

(b) Determine the response  $y(n)$ ,  $n \geq 0$  of the system described by the second order difference equation  $y(n) - 4y(n-1) + 4y(n-2) = x(n) - x(n-1)$  when the input is  $x(n) = (-1)^n u(n)$  and the

initial condition are  $y(-1) = y(-2) = 1$ .

12. State and prove any two properties of z-transform. (8)

13. Find the z-transform and ROC of the causal sequence.  $X(n) = \{1,0,3,-1,2\}$  (8)

14. Find the z-transform and ROC of the anticausal sequence  $X(n) = \{-3,-2,-1,0,1\}$  (8)

13. (a) Determine the z-transform and ROC of the signal i)  $x(n) = a^n u(n)$  and ii)  $x(n) = -b^n u(-n-1)$

(b) Find the stability of the system whose impulse response  $h(n) = (2)^n u(n)$  (16)

14. (a) Determine the z-transform of  $x(n) = \cos \omega n u(n)$  (8)

(b) State and prove the following properties of z-transform. i) Time shifting ii) Time reversal iii)

Differentiation iv) Scaling in z-domain (8)

15. Determine the inverse z-transform of  $x(z) = (1+3z^{-1}) / (1+3z^{-1}+2z^{-2})$  for  $z > 2$  (8)

16. Find the inverse z-transform of  $x(z) = (z^2+z) / (z-1)(z-3)$ , ROC:  $z > 3$ . Using (i) Partial fraction method, (ii) Residue method and (iii) Convolution method (16)

17. Determine the unit step response of the system whose difference equation is

$y(n)-0.7y(n-1)+0.12y(n-2) = x(n-1)+x(n-2)$  if  $y(-1) = y(-2) = 1$ . (8)

18. Determine the convolution sum of two sequences  $x(n) = \{3,2,1,2\}$ ,  $h(n) = \{1,2,1,2\}$  (8)

19.. Find the convolution of the signals  $x(n) = 1 \text{ } n = -2, 0, 1 = 2 \text{ } n = -1 = 0$  elsewhere  $h(n) = \delta(n) - \delta(n -$

$$1) + \delta(n-2) - \delta(n-3) \quad (8)$$

## UNIT II – FREQUENCY TRANSFORMATIONS

### Part A

#### 1. Define DFT and IDFT (or) what are the analysis and synthesis equations of DFT

DFT (Analysis Equation)

IDFT (Synthesis Equation)

#### 4. State the properties of DFT

Periodicity

Linearity and symmetry Multiplication of two DFTs Circular convolution

Time reversal

Circular time shift and frequency shift Complex conjugate

Circular correlation

#### 5. Define circular convolution

Let  $x_1(n)$  and  $x_2(n)$  are finite duration sequences both of length  $N$  with DFTs  $X_1(k)$  and  $X_2(k)$

(k). If  $X_3(k) = X_1(k) X_2(k)$  then the sequence  $x_3(n)$  can be obtained by circular convolution defined as

#### 4. How to obtain the output sequence of linear convolution through circular convolution

Consider two finite duration sequences  $x(n)$  and  $h(n)$  of duration  $L$  samples and  $M$  samples. The linear convolution of these two sequences produces an output sequence of duration  $L+M-1$  samples. Whereas, the circular convolution of  $x(n)$  and  $h(n)$  give  $N$  samples where  $N = \max(L, M)$ . In order to obtain the number of samples in circular convolution equal to  $L+M-1$ , both  $x(n)$  and  $h(n)$  must be appended with appropriate number of zero valued samples. In other words by increasing the length of the sequences  $x(n)$  and  $h(n)$  to  $L+M-1$  points and then circularly convolving the resulting sequences we obtain the same result as that of linear convolution.

## 5. What is zero padding? What are its uses?

Let the sequence  $x(n)$  has a length  $L$ . If we want to find the  $N$ -point DFT ( $N > L$ ) of the sequence  $x(n)$ , we have to add  $(N-L)$  zeros to the sequence  $x(n)$ . This is known as zero padding. The uses of zero padding are

We can get better display of the frequency spectrum.  
With zero padding, the DFT can be used in linear filtering.

## 6. Define sectional convolution.

If the data sequence  $x(n)$  is of long duration it is very difficult to obtain the output sequence  $y(n)$  due to limited memory of a digital computer. Therefore, the data sequence is divided up into smaller sections. These sections are processed separately one at a time and controlled later to get the output.

## 7. What are the two methods used for the sectional convolution?

The two methods used for the sectional convolution are  
1) The overlap-add method and 2) overlap-save method.

## 8. What is overlap-add method?

In this method the size of the input data block  $x_i(n)$  is  $L$ . To each data block we append  $M-1$  zeros and perform  $N$  point circular convolution of  $x_i(n)$  and  $h(n)$ . Since each data block is terminated with  $M-1$  zeros the last  $M-1$  points from each output block must be overlapped and added to first  $M-1$  points of the succeeding blocks. This method is called overlap-add method.

## 9. What is overlap-save method?

In this method, the data sequence is divided into  $N$  point sections  $x_i(n)$ . Each section contains the last  $M-1$  data points of the previous section, followed by  $L$  new data points to form a data sequence of length  $N=L+M-1$ . In circular convolution of  $x_i(n)$  with  $h(n)$  the first  $M-1$  points will not agree with the linear convolution of  $x_i(n)$  and  $h(n)$  because of aliasing, the remaining points will agree with linear convolution. Hence we discard the first  $(M-1)$  points of filtered section  $x_i(n) * h(n)$

( $n$ ). This process is repeated for all sections and the filtered sections are abutted together.

## 10. Why FFT is needed?

The direct evaluation DFT requires  $N^2$  complex multiplications and  $N^2 - N$  complex additions. Thus for large values of  $N$  direct evaluation of the DFT is difficult. By using FFT algorithm, the number of complex computations can be reduced. Therefore, we use FFT.

### **11. What is FFT?**

The Fast Fourier Transform is an algorithm used to compute the DFT. It makes use of the symmetry and periodicity properties of twiddle factor to effectively reduce the DFT computation time. It is based on the fundamental principle of decomposing the computation of DFT of a sequence of length  $N$  into successively smaller DFTs.

### **12. How many multiplications and additions are required to compute $N$ point DFT using radix-2 FFT?**

The number of multiplications and additions required to compute  $N$  point DFT using radix-2 FFT are  $N \log_2 N$  and  $N/2 \log_2 N$  respectively.

### **13. What is meant by radix-2 FFT?**

The FFT algorithm is most efficient in calculating  $N$  point DFT. If the number of output points  $N$  can be expressed as a power of 2 that is  $N = 2^M$ , where  $M$  is an integer, then this algorithm is known as radix-2 algorithm.

### **14. What is DIT algorithm?**

Decimation-In-Time algorithm is used to calculate the DFT of an  $N$  point sequence. The idea is to break the  $N$  point sequence into two sequences, the DFTs of which can be combined to give the DFT of the original  $N$  point sequence. This algorithm is called DIT because the sequence  $x(n)$  is often splitted into smaller sub-sequences.

### **15. What is DIF algorithm?**

It is a popular form of the FFT algorithm. In this the output sequence  $X(k)$  is divided into smaller and smaller sub-sequences, that is why the name Decimation - In - Frequency.

### **16. What are the applications of FFT algorithm?**

- The applications of FFT algorithm includes
- Linear filtering
  - 
  - Correlation

Spectrum analysis

### **17. Why the computations in FFT algorithm is said to be in place?**

Once the butterfly operation is performed on a pair of complex numbers  $(a, b)$  to produce  $(A, B)$ , there is no need to save the input pair. We can store the result  $(A, B)$  in the

same locations as (a, b). Since the same storage locations are used throughout the computation, we say that the computations are done in place.

**18. Distinguish between linear convolution and circular convolution of two sequences.**

<b>Linear convolution</b>	<b>Circular convolution</b>
If $x(n)$ is a sequence of $L$ number of samples and $h(n)$ with $M$ number of samples, after convolution $y(n)$ will have $N=L+M-1$ samples.	If $x(n)$ is a sequence of $L$ number of samples and $h(n)$ with $M$ samples, after convolution $y(n)$ will have $N=\max(L,M)$ samples.
It can be used to find the response of a linear filter	It cannot be used to find the response of a filter
Zero padding is not necessary to find the response of a linear filter.	Zero padding is necessary to find the response

**19. What are the differences and similarities between DIF and DIT algorithms?**

***Differences:***

- 1) The input is bit reversed while the output is in natural order for DIT, whereas for DIF the output is bit reversed while the input is in natural order.
- 2) The DIF butterfly is slightly different from the DIT butterfly, the difference being that the complex multiplication takes place after the add-subtract operation in DIF.

***Similarities:***

Both algorithms require same number of operations to compute the DFT. Both algorithms can be done in place and both need to perform bit reversal at some place during the computation.

**20. What are differences between overlap-save and overlap-add methods.**

<b>Overlap-save method</b>	<b>Overlap-add method</b>
In this method the size of the input data block is $N=L+M-1$	In this method the size of the input data block is $L$
Each data block consists of the last $M-1$ data points of the previous data block followed by $L$ new data points	Each data block is $L$ points and we append $M-1$ zeros to compute $N$ point DFT
In each output block $M-1$ points are corrupted due to aliasing as circular convolution is employed	In this no corruption due to aliasing as linear convolution is performed using circular convolution
To form the output sequence the first $M-1$ data points are discarded in each output block and the remaining data are fitted together	To form the output sequence the last $M-1$ points from each output block is added to the first $M-1$ points of the succeeding block

## 21. Distinguish between fourier series and Fourier Transform

Fourier Series	Fourier transform
Gives the harmonic content of a periodic time function.	Gives the frequency information for an aperiodic signal.

### PART B – 16 Marks

- (a) Determine the output response  $y(n)$  if  $h(n) = \{1,1,1,1\}$ ;  $x(n) = \{1,2,3,1\}$  by using (i) Linear convolution ii) Circular convolution and iii) Circular convolution with zero padding (12)

(b) Explain any two properties of Discrete Fourier Transform. (4)
- Using linear convolution find  $y(n) = x(n)*h(n)$  for the sequences  $x(n) = (1,2,-1,2,3,-2,-3,-1,1,1,2,-1)$  and  $h(n) = (1,2)$ . Compare the result by solving the problem using i) Over-lap save method and ii) Overlap – add method. (16)
- Describe the decimation in time [DIT] radix-2 FFT algorithm to determine N-point DFT. (16)
- An 8-point discrete time sequence is given by  $x(n) = \{2,2,2,2,1,1,1,1\}$ . Compute the 8-point DFT of  $x(n)$  using radix-2 FFT algorithm. (16)
- (a) Compute the 4-point DFT and FFT-DIT for the sequence  $x(n) = \{1,1,1,3\}$  and What are the basic steps for 8-point FFT-DIT algorithm computation? (12)

(b) What is the advantage of radix-2 FFT algorithm in comparison with the classical DFT method? (4)
- (a) Perform circular convolution of the two sequences graphically  $x_1(n) = \{2,1,2,1\}$  and  $x_2(n) = \{1,2,3,4\}$  (6)

(b) Find the DFT of a sequence by  $x(n) = \{1,2,3,4,4,3,2,1\}$  using DIT algorithm. (10)
- (a) Explain the decimation in frequency radix-2 FFT algorithm for evaluating N-point DFT of the given sequence. Draw the signal flow graph for  $N=8$ . (12)

(b) Find the IDFT of  $y(k) = \{1,0,1,0\}$  (4)

8. (a) Find the circular convolution of the sequences  $x_1(n) = \{1,2,3\}$  and  $x_2(n) = \{4,3,6,1\}$  (8)  
 (b) Write the properties of DFT and explain. (8)
9. (a) Draw the 8-point flow diagram of radix-2 DIF-FFT algorithm. (8)  
 (b) Find the DFT of the sequence  $x(n) = \{2,3,4,5\}$  using the above algorithm. (8)
10. (a) What are the differences and similarities between DIT and DIF FFT algorithms? (6)  
 (b) Compute the 8-point IDFT of the sequence  $x(k) = \{7, -0.707-j0.707, -j, 0.707-j0.707, 1, 0.707+j0.707, j, -0.707+j0.707\}$  using DIT algorithm. (10)
11. (a) Compute the 8-point DFT of the sequence  $x(n) = \{0.5,0.5,0.5,0.5,0,0,0,0\}$  using radix-2 DIT algorithm (8)  
 (b) Find the IDFT of the sequence  $x(k) = \{4,1-j2.414,0,1-j0.414,0,1+j.414,0,1+j2.414\}$  using DIF algorithm. (8)
12. Compute the 8-point DFT of the sequence  $x(n) = 1, 0 \leq n \leq 7$   
 $0, \text{ otherwise}$   
 by using DIT,DIF algorithms. (16)

### UNIT III IIR FILTER DESIGN

#### 1. What are the different types of filters based on impulse response?

Based on impulse response the filters are of two types

1. IIR filter
2. FIR filter

The IIR filters are of recursive type, whereby the present output sample depends on the present input, past input samples and output samples.

The FIR filters are of non recursive type, whereby the present output sample depends on the present input sample and previous input samples.

#### 2. What are the different types of filters based on frequency response?

Based on frequency response the filters can be classified as

- Lowpass filter
- Highpass filter
- Bandpass filter
- Bandreject filter



**3. What are the advantages and disadvantages of FIR filters?**

**Advantages:**

- a. FIR filters have exact linear phase.
- b. FIR filters are always stable.
- c. FIR filters can be realized in both recursive and non recursive structure.
- d. Filters with any arbitrary magnitude response can be tackled using FIR sequence.

**Disadvantages:**

- x For the same filter specifications the order of FIR filter design can be as high as 5 to 10 times that in an IIR design.
  
- x Large storage requirement is requirement
- x Powerful computational facilities required for the implementation.

**4. How one can design digital filters from analog filters?**

- Map the desired digital filter specifications into those for an equivalent analog filter.
- Derive the analog transfer function for the analog prototype.
- Transform the transfer function of the analog prototype into an equivalent digital filter transfer function.

**5. Mention the procedures for digitizing the transfer function of an analog filter.**

The two important procedures for digitizing the transfer function of an analog filter are

- Impulse invariance method.
- Bilinear transformation method.
- Approximation of derivatives

**6. Distinguish between FIR filters and IIR filters.**

<b>FIR filter</b>	<b>IIR filter</b>
These filters can be easily designed to have perfectly linear phase.	These filters do not have linear phase.
FIR filters can be realized recursively and non- recursively.	IIR filters are easily realized recursively
Greater flexibility to control the shape of their magnitude response.	Less flexibility, usually limited to specific kind of filters.
Errors due to round off noise are less severe in FIR filters, mainly because feedback is not used.	The round off noise in IIR filters is more.

**7. What do you understand by backward difference?**

One of the simplest methods for converting an analog filter into a digital filter is to approximate the differential equation by an equivalent difference equation.

$\frac{d}{dt} y(t) = y(nT) - y(nT - T)/T$

The above equation is called backward difference equation.

**8. What is the mapping procedure between S-plane & Z-plane in the method of mapping differentials? What are its characteristics?**

The mapping procedure between S-plane & Z-plane in the method of mapping of differentials is given by

$$H(Z) = H(S) \Big|_{S=(1-Z^{-1})/T}$$

*The above mapping has the following characteristics*

- The left half of S-plane maps inside a circle of radius 1/2 centered at Z= 1/2 in the Zplane.
- The right half of S-plane maps into the region outside the circle of radius 1/2 in the Z-plane.
- ii) The j .-axis maps onto the perimeter of the circle of radius 1/2 in the Z-plane.

**(c) What is meant by impulse invariant method of designing IIR filter?**

In this method of digitizing an analog filter, the impulse response of the resulting digital filter is a sampled version of the impulse response of the analog filter. If the transfer function is of the form, 1/s-p, then

$$(z) = 1/1 - e^{-pT}z^{-1}$$

**10. What is bilinear transformation?**

The bilinear transformation is a mapping that transforms the left half of S-plane into the unit circle in the Z-plane only once, thus avoiding aliasing of frequency components. The mapping from the S-plane to the Z-plane is in bilinear transformation is

$$S = \frac{2}{T} \frac{1 - Z^{-1}}{1 + Z^{-1}}$$

**11. What are the properties of bilinear transformation?**

- The mapping for the bilinear transformation is a one-to-one mapping that is for every point Z, there is exactly one corresponding point S, and vice-versa.
- The j .-axis maps on to the unit circle |z|=1, the left half of the s-plane maps to the interior of the unit circle |z|=1 and the half of the s-plane maps on to the exterior of the unit circle |z|=1.

**12. Write a short note on pre-warping.**

The effect of the non-linear compression at high frequencies can be compensated. When the desired magnitude response is piece-wise constant over frequency, this compression can be compensated by introducing a suitable pre-scaling, or pre-warping the critical frequencies by using the formula.

**13. What are the advantages & disadvantages of bilinear transformation?**

**Advantages:**

- The bilinear transformation provides one-to-one mapping.
- Stable continuous systems can be mapped into realizable, stable digital systems.
- There is no aliasing.

**Disadvantage:**

- The mapping is highly non-linear producing frequency, compression at high frequencies.
- Neither the impulse response nor the phase response of the analog filter is preserved in a digital filter obtained by bilinear transformation.

**14. Distinguish analog and digital filters**

Analog Filter	Digital Filter
Constructed using active or passive components and it is described by a differential equation	Consists of elements like adder, subtractor and delay units and it is described by a difference equation
Frequency response can be changed by changing the components	Frequency response can be changed by changing the filter coefficients
It processes and generates analog output	Processes and generates digital output
Output varies due to external conditions	Not influenced by external conditions

**15. What are the properties of chebyshev filter?**

1. The magnitude response of the chebyshev filter exhibits ripple either in the stop band or the pass band.
2. The poles of this filter lies on the ellipse

**16. List the Butterworth polynomial for various orders.**

N	Denominator polynomial
1	$S+1$
2	$S^2+.707s+1$
3	$(s+1) (s^2+s+1)$
4	$(s^2+.7653s+1) (s^2+1.84s+1)$
5	$(s+1) (s^2+.6183s+1) (s^2+1.618s+1)$

6	$(s^2+1.93s+1)(s^2+.707s+1)(s^2+.5s+1)$
7	$(s+1)(s^2+1.809s+1)(s^2+1.24s+1)(s^2+.48s+1)$

**17. Differentiate Butterworth and Chebyshev filter.**

Butterworth damping factor 1.44 chebyshev 1.06 Butterworth flat response damped response.

**18. What is filter?**

Filter is a frequency selective device, which amplifies particular range of frequencies and attenuate particular range of frequencies.

**PART B**

1. a) Derive bilinear transformation for an analog filter with system function

$$H(S) = b/S + a$$

b) Discuss the limitation of designing an IIR filter using impulse invariant method

2. Determine H (Z) for a Butterworth filter satisfying the following specifications:

$$0.8 \leq |H(e^{j\omega})| \leq 1, \text{ for } 0 \leq \omega \leq \pi/4$$

$$|H(e^{j\omega})| \leq 0.2, \text{ for } \pi/2 \leq \omega \leq \pi$$

Assume T= 0.1 sec. Apply bilinear transformation method

3. Determine digital Butterworth filter satisfying the following specifications:

$$0.707 \leq |H(e^{j\omega})| \leq 1, \text{ for } 0 \leq \omega \leq \pi/2$$

$$|H(e^{j\omega})| \leq 0.2, \text{ for } 3\pi/4 \leq \omega \leq \pi$$

Assume T= 1 sec. Apply bilinear transformation method.

4. Design a Chebyshev low pass filter with the specifications  $\alpha_p=1$  dB ripple in the pass band  $0 \leq \omega \leq 0.2\pi$ ,  $\alpha_s=15$  dB ripple in the stop band  $0.3 \pi \leq \omega \leq \pi$  using impulse invariance method

5. Design a Butterworth high pass filter satisfying the following specifications.

6. Design a Butterworth low pass filter satisfying the following specifications.

7. Design (a) a Butterworth and (b) a Chebyshev analog high pass filter that will pass all radian frequencies greater than 200 rad/sec with no more that 2 dB attenuation and have a stopband

$$f_p=0.10 \text{ Hz}; \alpha_p=0.5 \text{ dB}$$

$$f_s=0.15 \text{ Hz}; \alpha_s=15 \text{ dB}; F=1 \text{ Hz.}$$

attenuation of greater than 20 dB for all  $\Omega$  less than 100 rad/sec.

8. Design a digital filter equivalent to this using impulse invariant method  $H(S) = 10/S^2+7S+10$

9. Use impulse invariance to obtain  $H(Z)$  if  $T= 1$  sec and  $H(s)$  is

$$\frac{1}{(s^3+3s^2+4s+1)}$$

$$\frac{1}{(s^2+\sqrt{2}s+1)}$$

10. Use bilinear transformation method to obtain  $H(Z)$  if  $T= 1$  sec and  $H(s)$  is

$$\frac{1}{(s+1)(S+2)}$$

$$\frac{1}{(s^2+\sqrt{2}s+1)}$$

11. Briefly explain about bilinear transformation of digital filter design

12. Design a chebyshev filter with a maximum pass band attenuation of 2.5 Db; at  $\Omega_p=20$  rad/sec and the stop band attenuation of 30 Db at  $\Omega_s=50$  rad/sec.

13. Describe various Structures of IIR filter Design

14. Realize the system given by difference equation  $-0.1y(n-1)+0.72y(n-2)+0.7x(n)-0.25x(n-2)$  in parallel form

15. Design a butterworth high pass filter satisfying  $F_p = 0.32$ ,  $\alpha_p=0.5\text{db}$ ,  $F_s= 0.16\text{Hz}$ ,  $\alpha_s=30\text{db}$ ,  $F=1\text{Hz}$

## UNIT IV – FIR FILTER DESIGN

### Part-A

**1. How phase distortion and delay distortion are introduced?**

The phase distortion is introduced when the phase characteristics of a filter is nonlinear within the desired frequency band. The delay distortion is introduced when the delay is not constant within the desired frequency band.

**2. What is mean by FIR filter?**

The filter designed by selecting finite number of samples of impulse response  $h(n)$  obtained from inverse Fourier transform of desired frequency response  $H(\omega)$  are called FIR filters

**4. Write the steps involved in FIR filter design**

Choose the desired frequency response  $H_d(\omega)$

Take the inverse Fourier transform and obtain  $H_d(n)$  Convert the infinite duration

sequence  $H_d(n)$  to  $h(n)$  Take Z transform of  $h(n)$  to get  $H(Z)$

**5. Give the advantages of FIR filter?**

Linear phase FIR filter can be easily designed  
Efficient realization of FIR filter exists as both recursive and non-recursive structures.  
FIR filter realized non-recursively stable.

The round off noise can be made small in non recursive realization of FIR filter.

**5. List the disadvantages of FIR FILTER**

The duration of impulse response should be large to realize sharp cutoff filters. The non integral delay can lead to problems in some signal processing applications.

**6. Define necessary and sufficient condition for the linear phase characteristic of a FIR filter?**

The phase function should be a linear function of  $\omega$ , which in turn requires constant group delay and phase delay.

**6. List the well-known design technique for linear phase FIR filter design?**

Fourier series method and window method  
Frequency sampling method  
Optimal filter design method

**7. For what kind of application, the anti-symmetrical impulse response can be used?**

The anti-symmetrical impulse response can be used to design Hilbert transforms and differentiators.

**9. For what kind of application, the symmetrical impulse response can be used?**

The impulse response, which is symmetric having odd number of samples, can be used to design all types of filters, i.e., lowpass, highpass, bandpass and band reject. The symmetric impulse response having even number of samples can be used to design lowpass and bandpass filter.

**10. Justify that that FIR filter is always stable?**

FIR filter is always stable because all its poles are at the origin.

**11. What condition on the FIR sequence  $h(n)$  are to be imposed in order that this filter can be called a linear phase filter?**

The conditions are

- (i) Symmetric condition  $h(n) = h(N-1-n)$
- (ii) Antisymmetric condition  $h(n) = -h(N-1-n)$

**12. Under what conditions a finite duration sequence  $h(n)$  will yield constant group delay in its frequency response characteristics and not the phase delay?**

If the impulse response is anti symmetrical, satisfying the condition  $H(n) = -h(N-1-n)$

The frequency response of FIR filter will have constant group delay and not the phase delay.

**13. What are the properties of FIR filter?**

1. FIR filter is always stable.
2. A realizable filter can always be obtained.
3. FIR filter has a linear phase response.

**14. When cascade form realization is preferred in FIR filters?**

The cascade form realization is preferred when complex zeros with absolute magnitude less than one.

**15. What are the disadvantages of Fourier series method?**

In designing FIR filter using Fourier series method the infinite duration impulse response is truncated at  $n = \pm (N-1/2)$ . Direct truncation of the series will lead to fixed percentage overshoots and undershoots before and after an approximated discontinuity in the frequency response.

**16. Define Gibbs phenomenon? OR What are Gibbs oscillations?**

One possible way of finding an FIR filter that approximates  $H(e^{j\omega})$  would be to truncate the infinite Fourier series at  $n = \pm (N-1/2)$ . Abrupt truncation of the series will lead to oscillation both in pass band and in stop band. This phenomenon is known as Gibbs phenomenon.

**17. Give the desirable characteristics of the windows?**

The desirable characteristics of the window are

1. The central lobe of the frequency response of the window should contain most of the energy and should be narrow.
2. The highest side lobe level of the frequency response should be small.
3. The side lobes of the frequency response should decrease in energy rapidly as  $\omega$  tends to  $\pi$ .

**18. What is the necessary and sufficient condition for linear phase characteristics in FIR filter?**

The necessary and sufficient condition for linear phase characteristics in FIR filter is the impulse response  $h(n)$  of the system should have the symmetry property, i.e.,  $H(n) = h(N-1-n)$  Where  $N$  is the duration of the sequence

**19. What are the advantages of Kaiser Window?**

- It provides flexibility for the designer to select the side lobe level and  $N$ .
- It has the attractive property that the side lobe level can be varied continuously from the low value in the Blackman window to the high value in the rectangle window.

**20. What is the principle of designing FIR filter using frequency sampling method?**

In frequency sampling method the desired magnitude response is sampled and a linear phase response is specified. The samples of desired frequency response are defined as DFT coefficients. The filter coefficients are then determined as the IDFT of this set of samples.

**21. For what type of filters frequency sampling method is suitable?**

Frequency sampling method is attractive for narrow band frequency selective filters where only a few of the samples of the frequency response are non-zero.

**22. Compare FIR and IIR filter**

S.No	FIR Filter	IIR Filter
1.	The impulse response of this filter is restricted to finite number of samples	The impulse response extends to infinite duration
2.	FIR Filters have linear phase	IIR filter don't have linear phase
3.	Always stable	Not always stable
4.	Greater flexibility	Less flexibility
5.	Errors due to roundoff noise are less severe	IIR filters are more susceptible to errors due to roundoff noise

**23. Give the equation specifying Hanning and Blackmann window**

**Hanning Window**

$$WH(n) = 0.5 + 0.5 \cos(2\pi n / N - 1), \quad (N-1)/2 \leq n \leq (N-1)/2$$

$$= 0, \quad \text{otherwise}$$

**Blackmann Window**

$$WB(n) = 0.42 + 0.5 \cos(2\pi n / N - 1) + 0.08 \cos(4\pi n / N - 1), \quad -(N-1)/2 \leq n \leq (N-1)/2$$

$$= 0, \quad \text{else}$$

**24. What do you understand by Linear Phase Response in filters?**

In linear phase filter ( )  $\alpha$ , the linear phase filter does not alter the shape of the original signal. If phase response of the filter is nonlinear the output signal is distorted one. In many cases Linear Phase filter is required throughout the passband of the filter to preserve the shape of the given signal within the pass band. An IIR filter cannot produce a linear phase. The FIR filter can give linear phase, when the impulse response of the filter is symmetric about its midpoint.

**25. State Frequency Warping**

Because of the non-linear mapping: the amplitude response of digital IIR filter is expand at lower frequencies and compressed at higher frequencies in comparison to the analog filter.

**26. What is the importance of poles in filter design?**

The stability of a filter is related to the location of the poles. For a stable analog filter the poles should lie on the left half of s-plane. For a stable digital filter the poles should lie inside the unit circle in the z-plane.

**27. State the condition for a digital filter to be causal and stable**

Causal----- $h(n) = 0$  for  $n < 0$

Stable -----



**(d) Write the procedure for designing FIR filter using windows**

- i) Choose Desired Frequency Response  $H_d(\omega)$
- ii) Find Infinite Impulse Response Sequence  $h_d(n) = 1/2\pi$
- iii) Multiply the Infinite Impulse response to obtain filter coefficients  $h(n)$  and to make it finite

$$h(n) = h_d(n)w(n),$$

$$= 0, \text{ otherwise}$$

4. Find the transfer function of the realizable filter  $H(Z) = z^{-(N-1)/2}[h(0) +$

**29. Write the procedure for designing FIR filter using Frequency Sampling Method**

Find phase

Choose Desired frequency response  $H_d(\omega)$

Find Filter Coefficients  $h(n)$

**11. What are the applications of FIR Filters? Symmetric Response**

To design all types of filter such as HPF, LPF, BPF, BSF

**Antisymmetric Response**

To design Hilbert Transformer and Differentiator

**PART - B**

- 1. Write the expressions for the Hamming, Hanning, Bartlett and Kaiser windows (6)
- 2. Explain the design of FIR filters using windows. (10)
- 3. Design an ideal high pass filter with

—

Using Hanning window for  $N=11$ . (16)

4. Design an ideal high pass filter with

$$H_d(e^{j\omega}) = 1 \quad \text{for } \pi/4 \leq \omega \leq \pi$$
$$= 0 \quad \text{for } \omega \leq \pi/4$$

Using Hamming window for  $N=11$ . (16)

- 5. Using a rectangular window technique design a lowpass filter with pass band gain of unity, cutoff frequency of 1000 Hz and working at a sampling frequency of 5 kHz. The length of the impulse response should be 7. (16)
- 6. Design a FIR linear phase digital filter approximating the ideal frequency response (16)

$$H_d(\omega) = \begin{cases} 1, & \text{for } |\omega| \leq \frac{\pi}{6} \\ 0, & \text{for } \frac{\pi}{6} < |\omega| \leq \pi \end{cases}$$

With T=1 Sec using bilinear transformation .Realize the same in Direct form II

7. Obtain direct form and cascade form realizations for the transfer function of the system

givenby (10)

$$H(z) = \left(1 + \frac{1}{4}z^{-1} + \frac{3}{8}z^{-2}\right) \left(1 - \frac{1}{8}z^{-1} - \frac{1}{2}z^{-2}\right)$$

8. Design a LPF for the following response using hamming window with N=7 (8)

$$H(e^{j\omega})$$

9. Prove that an FIR filter has linear phase if the unit sample response satisfies the condition  $h(n) = \pm h(M-1-n)$ ,  $n=0,1,\dots,M-1$ . Also discuss symmetric and antisymmetric cases of FIR

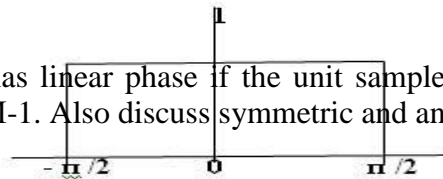

filter (8)

10. Explain the need for the use of window sequences in the design of FIR filter. Describe the

window sequences generally used and compare their properties (16)

11. Explain the need for the use of window sequences in the design of FIR filter. Describe the

window sequences generally used and compare their properties. (16)

12. Realize the following system using minimum number of multipliers

$$1 - 2Z^{-1} + 3Z^{-2} - 4Z^{-3} + 5Z^{-4} - 6Z^{-5} + 3Z^{-6} - 2Z^{-7} + Z^{-8}$$

(i)  $H(z) = 1 + 2Z^{-1} + 3Z^{-2} + 4Z^{-3} + 5Z^{-4} + 6Z^{-5} + 3Z^{-6} + 2Z^{-7} + Z^{-8}$  (8)

13. Design an ideal band reject filter using Hamming window for the given frequency

response. Assume N=11 (16)

$$H_d(e^{j\omega}) = \begin{cases} 1; & |\omega| \leq \pi/3 \text{ and } |\omega| \geq 2\pi/3 \\ 0; & \text{otherwise} \end{cases}$$

14. Design an FIR filter using Hanning window with the following specification (16)

$$H_d(e^{j\omega}) = \begin{cases} 1 & \text{for } \frac{\pi}{4} \leq \omega \leq \frac{\pi}{4} \\ e^{-j2\omega} & \text{for } \frac{\pi}{4} \leq |\omega| \leq \pi \end{cases}$$

15. Using a rectangular window technique, design a low pass filter with pass band gain of unity cut off frequency of 1000Hz and working at a sampling frequency of 5 kHz. The length of the impulse response should be 7. (8)

16. Design an ideal band pass filter with a frequency response. (16)

$$H_d(e^{j\omega}) = \begin{cases} 1 & \text{for } \pi/4 \leq |\omega| \leq 3\pi/4 \\ 0 & \text{otherwise} \end{cases}$$

**Find the values of h(n) for N = 7. Find the realizable filter transfer function and magnitude function of**

17. Design a digital FIR band pass filter with lower cut off frequency 2000Hz and upper cut off frequency 3200 Hz using Hamming window of length N = 7. Sampling rate is 10000Hz. (8)

18. Design an FIR low pass digital filter using the frequency sampling method for the following specifications (16)

**Cut off frequency = 1500Hz Sampling frequency = 15000Hz Order of the filter N = 10 Filter Length required L = N+1 = 11**

19. Determine the coefficients of a linear phase FIR filter of length M = 15 which has a symmetric unit sample response and a frequency response that satisfies the conditions. (8)

$$H_r\left(\frac{2\pi k}{15}\right) = \begin{cases} 1 & k = 0, 1, 2, 3 \\ 0.4 & k = 4 \\ 0 & k = 5, 6, 7 \end{cases}$$

20. Draw THREE different FIR structures for the H(z) given below: (10)

$$H(Z) = (1+5Z^{-1}+6Z^{-2})(1+Z^{-1})$$

## UNIT V

### FINITE WORD LENGTH EFFECTS IN DIGITAL FILTERS

#### PART A

##### **1. Define 1's complement form?**

In 1's complement form the positive number is represented as in the sign magnitude form. To obtain the negative of the positive number, complement all the bits of the positive number.

##### **2. What is meant by 2's complement form?**

In 2's complement form the positive number is represented as in the sign magnitude form. To obtain the negative of the positive number, complement all the bits of the positive number and add 1 to the LSB.

##### **3. Define floating point representation?**

In floating point form the positive number is represented as  $F = 2^C M$ , where  $M$  is mantissa, is a fraction such that  $1/2 < M < 1$  and  $C$  the exponent can be either positive or negative.

##### **3. List the advantages of floating point representation?**

1. Large dynamic range 2. Overflow is unlikely.

##### **4. Give the different quantization errors occur due to finite word length registers in digital filters?**

1. Input quantization errors 2. Coefficient quantization errors 3. Product quantization errors

##### **5. What do you understand by input quantization error?**

.In digital signal processing, the continuous time input signals are converted into digital by using  $b$  bit ADC. The representation of continuous signal amplitude by a fixed digit produces an error, which is known as input quantization error.

##### **6. Define product quantization error?**

The product quantization errors arise at the output of the multiplier. Multiplication of a  $b$  bit data with a  $b$  bit coefficient results a product having  $2b$  bits. Since a  $b$  bit register is used the multiplier output will be rounded or truncated to  $b$  bits which produce the error.

##### **7. Mention the different quantization methods available for Finite Word Length Effects?**

2. Truncation
- i Rounding

### 8. State truncation?

Truncation is a process of discarding all bits less significant than LSB that is retained.

### 9. Define Rounding?

Rounding a number to b bits is accomplished by choosing a rounded result as the b bit number closest number being unrounded.

### 10. List the two types of limit cycle behavior of DSP?

1. Zero limit cycle behavior
2. Over flow limit cycle behavior

### 11. Mention the methods to prevent overflow?

1. Saturation arithmetic
2. Scaling

### 12. Give the different types of arithmetic in digital systems.

There are three types of arithmetic used in digital systems. They are fixed point arithmetic, floating point, block floating point arithmetic.

### 13. What is meant by fixed point number?

In fixed point number the position of a binary point is fixed. The bit to the right represent the fractional part and those to the left is integer part.

### 14. What are the different types of fixed point arithmetic?

Depending on the negative numbers representation, there are three forms of fixed point arithmetic. They are sign magnitude, 1's complement, 2's complement

### 15. Distinguish between fixed point and floating point arithmetic

S.No	Fixed Point Arithmetic	Floating Point Arithmetic
1.	Fast Operation	Slow Operation
2.	Relatively Economical	More expensive because of costlier hardware
3.	Overflow occurs in addition	Overflow does not arise
4.	Used in small computers	Used in large general purpose computers
5.	Small Dynamic Range	Increased dynamic range

**16. Express the fraction 7/8 and -7/8 in sign magnitude, 1's and 2's complement.**

7/8

Sign magnitude----- (0.111)<sub>2</sub>

1's complement----- (0.111)<sub>2</sub>

2's complement----- (0.111)<sub>2</sub>

-7/8

Sign magnitude----- (1.111)<sub>2</sub>

1's complement----- (1.000)<sub>2</sub>

2's complement----- (0.001)<sub>2</sub>

**17. Draw the quantization noise model for a I order System**

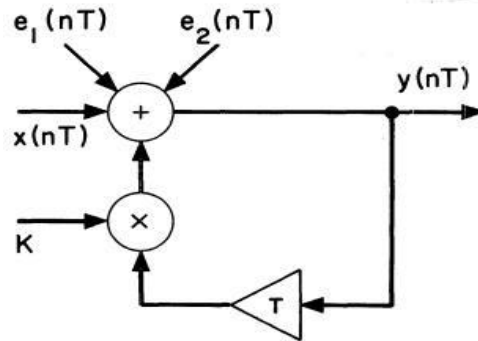

**18. What do you understand by (Zero input) Limit cycle oscillations?**

When a stable IIR filter digital filter is excited by a finite sequence, that is constant, the output will ideally decay to zero. However, the non-linearity due to finite precision arithmetic operations often causes periodic oscillations to occur in the output. Such oscillations occur in the recursive systems are called Zero input Limit Cycle Oscillation. Normally oscillations in the absence of output  $u(k) = 0$  by equation given below is called Limit cycle oscillations

$$Y[k] = -0.625.y[k-1] + u[k]$$

**19. Determine Dead Band of the Filter.**

The Limit cycle occurs as a result of quantization effect in multiplication. The amplitude of output during a limit cycle are confined to a range of values called the dead band of the filter

### 13. Why Rounding is preferred to truncation in realizing digital filter?

- i The quantization error due to rounding is independent of type arithmetic
- ii The mean of rounding error is zero
- iii The variance of rounding error is low

### 14. Define overflow oscillations

The overflow caused by adder makes the filter output to oscillate between maximum amplitude limits and such oscillations is referred as overflow oscillations

### 20. What is meant by sign magnitude representation?

For sign magnitude representation the leading binary digit is used to represent the sign. If it is equal to 1 the number is negative, otherwise it is positive.

## PART B

15. Discuss in detail the errors resulting from rounding and truncation?

16. (i) Explain the limit cycle oscillations due to product round off and overflow errors?

- 1. Explain how reduction of product round-off error is achieved in digital filters?

17. (i) Explain the effects of co-efficient quantization in FIR filters?

- 1. Distinguish between fixed point and floating point arithmetic

18. With respect to finite word length effects in digital filters, with examples discuss about

- 4. Over flow limit cycle oscillation

Signal scaling

5. Consider a second order IIR filter with

$$H(Z) = \frac{1}{1-0.95z^{-1}+0.255z^{-2}}$$

Find the effect on quantization on pole locations of the given system function in direct form and in cascade form. Assume  $b = 3$  bits.

6. What is called quantization noise? Derive the expression for quantization noise power.

7. (i) Compare the truncation and rounding errors using fixed point and floating point representation.

(ii) Represent the following numbers in floating point format with five bits for mantissa and three bits for exponent.

710

0.2510

-710

-0.2510

8. Determine the dead band of the system  $y(n) = 0.2y(n-1) + 0.5y(n-2) + x(n)$  Assume 8 bits are used for signal representation.
9. (a) i) Explain the characteristics of limit cycle oscillation with respect to the system described by the difference equation :  $y(n) = 0.95 y(n-1) + x(n)$  ;  $x(n)= 0$  and  $y(n-1)= 13$ .  
Determine the dead range of the system.  
ii) Explain the effects of coefficient quantization in FIR filters.
10. i) Derive the signal to quantization noise ratio of A/D converter.  
ii) Compare the truncation and rounding errors using fixed point and floating point representation.

**WIRELESS COMMUNICATION**  
**UNIT I WIRELESS CHANNELS**  
**PART A**

**1. Write the effects of fading.**

1. Rapid changes in signal strength over a small travel distance or time interval.
2. Random frequency modulation due to varying Doppler shifts on different multipath signals
3. Time dispersion caused by multipath propagation delays.

**2. Define coherence bandwidth. (May 2016)**

The coherence bandwidth is related to the specific multipath structure of the channel. The coherence bandwidth is a measure of the maximum frequency difference for which signals are still strongly correlated in amplitude. This bandwidth is inversely proportional to the rms value of time delay spread.

**3. What is coherence time?**

It is defined as the required time interval to obtain an envelope correlation of 0.9 or less.



#### 4. Define Doppler shift.

The shift in received signal frequency due to motion is called the Doppler shift.

#### 5. What is Doppler spread?

It is defined as the range of frequencies over which the received Doppler spectrum is essentially non-zero.

#### 6. What are the effects of multipath propagation? Slow fading and fast fading

#### 7. What is flat fading?

If the mobile radio channel has a constant gain and linear phase response over a bandwidth which is greater than the bandwidth of the transmitted signal, then the received signal will undergo flat fading.

#### 8. Write the conditions for flat fading.

BW of signal  $\ll$  BW of channel  $B_s \ll B_c$   
Symbol period  $\gg$  Delay spread  $T \gg \sigma_\lambda$

#### 9. What is frequency selective fading?

If the channel possesses a constant gain and linear phase response over a bandwidth that is, smaller than the bandwidth of transmitted signal, then the channel creates frequency selective fading on the received signal.

#### 10. Write the conditions for frequency selective fading.

BW of signal  $>$  BW of channel  $B_s > B_c$   
Symbol period  $<$  Delay spread  $T_s < \sigma_\lambda$

#### 11. Define fast fading channel.

The channel impulse response changes rapidly within the symbol duration. This type of channel is called fast fading channel.

#### 12. Define slow fading channel.

The channel impulse response changes at a rate much slower than the transmitted baseband signal. This type of channel is called slow fading channel.

#### 13. What is meant by link budget?

A link budget is the clearest and the most intuitive way of computing the required transmit power.

#### **14. What is the need of path loss models in link budget design?**

The path loss models are used to estimate the received signal level as the function of distance it becomes possible to predict the SNR for a mobile communication system.

#### **15. What is ISI?**

Intersymbol interference (ISI) is a form of distortion of a signal in which one symbol interferes with subsequent symbols

#### **16. What is meant by small scale fading? (May 2013)**

The rapid fluctuations of the amplitudes, phases; or multipath delays of a radio signal over a short period of time or travel distance is known as small scale fading.

#### **17. What is meant by large scale fading? (May 2013)**

The rapid fluctuations of the amplitudes, phases, or multipath delays of a radio signal over a long period of time or travel distance is known as large scale fading.

#### **18. What are the factors influencing small scale fading?**

Speed of surrounding objects, Multipath propagation, Speed of the mobile, Transmission bandwidth of the signal

#### **19. What is meant by frequency dispersion?**

The received signal has a larger bandwidth than that of the transmitted signal, due to the different Doppler shifts introduced by the components of the multipath.

#### **20. What is free space propagation model?**

It is a model which is used to predict received signal strength, when unobstructed line of sight path between transmitter and receiver.

#### **21. What are Fresnel zones?**

The concentric circles on the transparent plane located between a transmitter and receiver represent the loci of the origins of secondary wavelets which propagate to the receiver such that the total path length **increases by  $\lambda/2$  for successive circles. These circles are called Fresnel zones.**

#### **22. Explain knife-edge diffraction model.**

Knife edge is the simplest of diffraction models, and the diffraction loss can be readily estimated using the classical Fresnel solution for the field behind the knife edge.

#### **23. Find the far field distance for an antenna with maximum dimension of 2m and operating frequency 1 GHz?(Dec 2015)**

$$D_f = 2D^2/\lambda = 2 * 2 * 2/0.3 = 26.7 \text{ m}$$

**24. Define Snell's law. (May 2013)**

Snell's law states that the ratio of the sines of the angles of incidence and refraction is equivalent to the ratio of phase velocities in the two media, or equivalent to the reciprocal of the ratio of the indices of refraction:

$$\frac{\sin \theta_1}{\sin \theta_2} = \frac{v_1}{v_2} = \frac{n_2}{n_1}$$

**25. Calculate the Brewster Angle for a wave impinging on ground having a permittivity of  $\epsilon_r = 5$ .(May 2016)**

$$= 0.409 \text{ Brewster Angle} = \sin^{-1}(0.409) = 24.14$$

**PART B -**

1. Discuss in brief about the Free-space and Two-Ray models.
  2. Explain i) Fading and ii) Multipath propagation.
  3. Write short notes on i) time-selective channels ii) frequency-selective channels
  4. Differentiate narrowband and wideband channels.
  5. What is link budget? Explain with an example how it can be computed for noise limited system.
  6. Write short notes on WSSUS channels.
  7. Explain coherence time and coherence bandwidth with expressions.
  8. Explain in detail about the parameters of mobile multipath channels **(May 2016)**.
  9. Explain Okumura-Hata empirical and Nakagami model in detail. **(May 2013)**
  10. Explain briefly on outdoor propagation model **(Dec 2014)**
  11. Describe in detail Two Ray Rayleigh Fading Model. **(Dec 2014)**
  12. (i) Explain on path loss estimation techniques using path loss models.  
(ii) Describe on Ricean Distribution **(Dec 2014)**
- In free space propagation describe how the signals are affected by reflection, diffraction and scattering. **(May 2016)**

**UNIT II CELLULAR ARCHITECTURE**

**PART A**

**1. What are the different types of multiple access schemes? (Dec 2013),(May 2016).** FDMA-Frequency division multiple access-different frequencies are assigned to different users TDMA-Time division multiple access-different time slots are assigned to different users. CDMA-Code division multiple access-each user is assigned a different code.

**2. What are the advantages of FDMA?**

The transmitter and receiver require much less digital signal processing, Synchronization is simple.

### **3. What are the disadvantages of FDMA?**

1. Sensitivity to fading 2. Sensitivity to random frequency modulation 3. Inter modulation

### **4. Define SAMA.**

Spread Aloha Multiple Access is a combination of CDMA and TDMA. The CDMA better suits for connection oriented services only and not for connection less burst data traffic because it requires to program both sender and receiver to access different users with different codes.

### **5. Define CDMA.**

Code Division Multiple Access systems use codes with certain characteristics to separate different users. To enable access to the shared medium without interference. The users use the same frequency and time to transmit data. The main problem is to find good codes and to separate this signal from noise. The good code can be found the following 2 characteristic 1. Orthogonal. 2. Autocorrelation.

### **6. What is SDMA?**

Space Division Multiple Access (SDMA) is used for allocating separated spaces to users in wireless networks. The basis for the SDMA algorithm is formed by cells and sector zed antennas which constitute the infrastructure implementing space division multiplexing (SDM).

### **7. What is FDD?**

In FDMA, the base station and the mobile station establish a duplex channel. The two directions, mobile station to base station and vice versa are separated using different frequencies. This Scheme is called Frequency Division Duplex (FDD)

### **8. What limits the number of user in TDM and FDM compared to CDM?**

The code space is huge compared to the frequency space and time space. Because of the limited time space and frequency space, the number of user in TDM and FDM are limited.

### **9. How does near and far effect influence CDMA? What are counter measurements?**

The near and far effect is a server problem of wireless networks using CDM. All signals should arrive at the receiver with more or less the same strength. Precise power control is needed to receive all senders with the same strength at a receiver.

### **10. Define FCA and DCA.**

Allocating a fixed frequencies for a channel is called as Fixed channel Allocation (FCA). In Dynamic Channel Allocation (DCA) scheme frequencies can only be borrowed, but it is also possible to freely allocate frequencies to cells. With dynamic assignment of frequencies to cells, the danger of the interference with cells with same frequency exists. Thus the borrowed frequencies in the surroundings cells can be blocked.

### **11. What is guard space?**

Guard spaces are needed to avoid frequency band overlapping is also called channel interference.

**12. What is guard space?**

Guard spaces are needed to avoid frequency band overlapping is also called channel interference.

**13. When handoff occurs?**

Hand-off occurs when a received signal from its serving cell becomes weak and another cell site can provide a stronger signal to the mobile subscriber. If the new cell-site has some free voice channels then it assigns one of them to the handed-off call.

**14. Differentiate soft and hard handoff. (May 2016).**

Hard handoff mode is characterized by a mobile having a radio link with only AP at any time. Thus, the old connection is terminated before a new connection is activated. This mode of operation is referred to as break before make.

In Soft handoff, the mobile can simultaneously communicate with more than one AP during the handoff.

This new connection is made before breaking the old connection, and it is referred to as make before break.

**15. What is the function of Medium Access Control Layer?**

The functions of Medium Access Control Layer are responsible for establishing, maintaining, and releasing channels for higher layers by activating and deactivating physical channels.

**16. What are the 2 sub layers in DLC?**

Logical Link Control(LLC), Media Access Control (MAC)

**17. Define traffic multi frame and control multi frame?**

The periodic pattern of 26 slots occurs in all TDMA frames with a TCH. The combination of these frames is called traffic multi frame TDMA frames containing data for the other logical channels are combined into a control multi frame.

**18. What is the function of Medium Access Control Layer?**

The functions of Medium Access Control Layer which are responsible for establishing, maintaining, and releasing channels for higher layers by activating and deactivating physical channels.

**19. What is orthogonality?**

**Orthogonality** means if we have “n” users and n-bit sequences, then a set of vectors in n-space are orthogonal if any point in n-space may be expressed as only linear combination of these vectors.

CDMA is a communication technique that allows multiple users to communicate over one frequency. This is achieved through the use of spreading codes, whereby a single data bit is spread over a longer sequence of transmitted bits. These codes known as chip sequence, must be carefully chosen so that data may be correctly despread at the receiver. Such codes are known as orthogonal codes.

**20. Define Set-up time.**

The time required to allocate a trunked radio channel to a requesting user.

**21. What is a blocked call?**

Call which cannot be completed at time of request, due to congestion. Also referred to as lost call.

**22. Define Holding-time.**

Average duration of a typical call. Denoted by 'H' (in seconds).

**23. State advantages of CDMA over FDMA?(Dec2014)**

CDMA technology has bandwidth thirteen times efficient than FDMA and forty times efficient than analog systems. CDMA also has better security and higher data and voice transmission quality because of the spread spectrum technology it uses, which has increased resistance to multipath distortion. CDMA has greater coverage area when compared to FDMA. The main advantage of the CDMA is that, in the single detection method it is more flexible than FDMA or joint detection. CDMA is said to have higher capacity than FDMA.

**24. Define co-channel reuse ratio?(Dec2015)**

Co-channel reuse ratio Q is given as

$Q = D/R$ , D – is the distance between centres of cells, R – radius of the hexagonal cell

**25. Define Grade of Service?(Dec2015)**

Grade of Service in Wireless communication can be defined as ability of the user to connect on a call when the cell is being used by multiple users. It can be given by the ratio of number of blocked calls to the number of offered calls.

**PART B**

1. Compare and Contrast the TDMA, FDMA and CDMA techniques. (May 2016) (June 2013).
2. Describe the Channel Assignment Strategies.
3. Describe the Operations of Cellular systems and Explain its steps with a neat sketch (June 2013)
4. Explain in detail about multiple accesses with collision avoidance scheme. Also explain the advantages of the same. (Dec 2013) .
5. Explain the concept of cell planning with relevant diagrams and expressions.
6. Explain the various methods that increase the channel capacity and coverage. (May 2016).
7. Explain the principle of cellular networks and various types of Handoff techniques. (Dec 2013)(Dec 2014).
8. Write a note on trunking and grade of service.

9. A spectrum of 30MHz is allocated to a wireless FDD cellular system which uses two 25KHz simplex channels to provide full duplex voice and control channels, compute the number of channels available per cell if a system uses (a) four-cell reuse (b) seven-cell reuse, and (c) 12-cell reuse. If 1MHz of the allocated spectrum is dedicated to control channels, determine an equitable distribution of control

channels and voice channels in each cell for each of three systems.

10. Illustrate Cellular Frequency Reuse with a neat sketch.

## **UNIT III DIGITAL SIGNALLING FOR FADING CHANNELS**

### **PART A**

#### **1. Define modulation.**

It is defined as the process by which some parameters of a high frequency signal termed as carrier, is varied in accordance with the signal to be transmitted.

#### **2. What is demodulation?**

It is the process of recovering the original modulating signal from a modulated signal.

#### **3. Write the advantages of digital over analog modulation.**

Greater noise immunity, Robustness to channel impairments, Easier multiplexing of various forms of information, Greater security

#### **4. What is meant by Amplitude shift keying?**

If amplitude of the carrier is varied depending on the incoming digital signal, then it is called Amplitude shift keying.

#### **5. What is meant by Frequency shift keying?**

If the frequency of the sinusoidal carrier frequency is varied depending on the incoming digital signal, then it is called Frequency shift keying.

#### **6. What is meant by Phase shift keying?**

If phase of the carrier is varied depending on the input digital signal, then it is called phase shift keying.

#### **7. Define M-ary transmission system,**

In digital modulation instead of transmitting one bit at a time, two or more bits are transmitted simultaneously. This is called M-ary transmission.

## **8. What is Quadrature modulation?**

Sometimes two or more Quadrature carriers are used for modulation. It is called Quadrature modulation.

## **9. Explain the following terms                      a) Baud rate   b) Bit rate**

Baud rate: Speed at which symbols are transmitted in a digital communication system, i.e. no of symbols/second.

Bit rate: Speed at which data bits is transmitted in a digital communication system, i.e. no of bits/sec.

## **10. What is QAM?**

At high bit rates, a combination of ASK and PSK is employed in order to minimize the errors in the received data. This method is known as Quadrature amplitude modulation.

## **11. What is meant by QPSK?**

QPSK is a multi-level modulation in which four phase shifts are used for representing four different symbols.

## **12. What is linear modulation?**

In linear modulation technique, the amplitude of the transmitted (carrier) signal varies linearly with the modulating digital signal. In general, linear modulation does not have a constant envelope.

## **13. Write the merits of linear modulation.**

Bandwidth efficient, Very attractive for use in wireless communication systems, Accommodate more and more users within a limited spectrum.

## **14. What is nonlinear modulation?**

In nonlinear modulation, the amplitude of the carrier is constant regardless of the variation in the modulating signal.

## **15.   Mention the merits and demerits of nonlinear modulation.**

Merits:

a. Lower efficient class c amplifiers can be used without introducing degradation in the spectrum occupancy of the transmitted signal.



b. Low out of band radiation of the order of -60dB to -70dB can be achieved.

c. Limiter-discriminator detection can be used, which simplifies receiver design and provides high immunity against random FM noise and signal fluctuations due to Rayleigh fading.

Demerits:

a. Constant envelope modulations occupy a larger bandwidth than linear modulation scheme

b. In situations where bandwidth efficiency is more important than power efficiency, constant Envelope modulation is not well suited.

**16. What is the advantage of MSK over QPSK?**

In QPSK the phase changes by 90 or 180 degrees. This creates abrupt amplitude variations in the waveform. Therefore bandwidth requirement of QPSK is more. MSK overcomes this problem. In MSK, the output waveform is continuous in phase hence there are no abrupt changes in amplitude.

**17. Why MSK is called as fast FSK? (May 2016).**

MSK is called fast FSK, as the frequency spacing used is only half as much as that used in conventional non-coherent FSK.

**18. Mention some merits of MSK.**

Constant envelope, Spectral efficiency, Good BER performance, Self-synch on z g capability

**19. Why MSK cannot be directly used in multi user communications?**

1. The main lobe of MSK is wide. This makes MSK unsuitable for the applications where extremely narrow bandwidths and sharp cut-offs are required.
2. Slow decay of MSK power spectral density curve creates adjacent channel interference. Hence MSK cannot be used for multiuser communications.

**20. What is the need of Gaussian filter? (Dec 13)**

Gaussian filters used before the modulator to reduce the transmitted bandwidth of the signal. It uses less bandwidth than conventional FSK.

**21. Define M-ary FSK.**

In M-ary system,  $M=2^N$  different symbols are used and N no of bits per symbol. Every symbol uses separate frequency for transmission.

**22. Mention any two criteria for choosing a modulation technique for a specific wireless application? (June 2013)**

The spectral efficiency of the modulation format should be as high as possible. This can best be achieved by a higher order modulation format. This allows the transmission of many data bits with each symbol. Adjacent channel interference must be small. This entails that the power spectrum of the signal should show a strong roll-off outside the desired band. Furthermore, the signal must be filtered before transmission.

**23. Define cyclic prefix.**

In OFDM, delay dispersion leads to a loss of orthogonality between the subcarriers and thus leads to Inter Carrier Interference (ICI). These negative effects can be eliminated by a special type of guard interval called the cyclic prefix.

**24. Define Windowing.(May 2016).**

Windowing is a technique proposed to help reduce sensitivity to frequency offsets in an OFDM system. This process involves cyclically extending **the time domain signal with each symbol by 'v' samples**. The resulting signal is then shaped with a window function.

**25. Define PAPR.**

The peak to average power ratio PAPR is an important attribute of a communication system. A low PAPR allows the transmit power amplifier to operate efficiently, whereas a high PAPR forces the transmit power amplifier to have a large back off in order to ensure linear amplification of the signal.

**PART B**

1. Explain QPSK transmitter and receiver with signal space diagram and give an expression for spectral efficiency. **(Dec 2013)(Dec 2014)**
2. **Explain  $\pi/4$  Differential QPSK & OQPSK transmitter and receiver with signal space diagram and give an expression for spectral efficiency. (June 2013)(May 2016).**
3. Explain BFSK transmitter and receiver with signal space diagram and give an expression for spectral efficiency.**(Dec 2014)**
4. Explain MSK transmitter and receiver with signal space diagram and give an expression for spectral efficiency. **(June 2013),(Dec 2015)**
5. Explain GMSK transmitter and receiver with signal space diagram and give an expression for spectral efficiency.**(Dec 2015)(May 2016).**
6. Discuss about the performance of digital modulation in fading channels. **(Dec 2013)**
7. Explain the Nyquist criterion for ISI cancellation. **(Dec 2013)**

8. Explain in detail about OFDM modulation technique with necessary diagrams.  
9. (i) Describe with a block diagram  $\pi/4$  Quadrature phase shift keying and its advantages.

(ii) What is MSK? Explain its power spectral density. (Dec 2014)

## UNIT IV MULTIPATH MITIGATION TECHNIQUES

### PART A

1. **What are the techniques used to improve the received signal quality?** Equalization, Diversity and Channel coding

2. **What are the factors used in adaptive algorithms?** Rate of convergence, Misadjustment, Computational complexity and numerical properties.

3. **What is the need of equalization?**

Equalization is used to compensate the inter-symbol interference created by multipath within time dispersion channel.

4. **Write the functions of diversity. (Dec 2013)**

- i. Diversity is used to compensate for fading channel impairments, and is usually implemented by using two or more receiving antennas.
- ii. Diversity improves transmission performance by making use of more than one independently faded version of the transmitted signal.

5. **Define spatial diversity.**

The most common diversity technique is called spatial diversity, whereby multiple antennas are strategically spaced and connected to a common receiving system. While one antenna sees a signal null, one of the other antennas may see a signal peak, and the receiver is able to select the antenna with the best signals at any time.

6. **What is equalizer? (Dec 2013)**

The device which equalizes the dispersive effect of a channel is referred to as an equalizer.

7. **What are the operating modes available in an adaptive equalizer?** Training and tracking modes.

8. **Define adaptive equalizer. (May 2016).**

To combat ISI, the equalizer coefficients should change according to the channel status so as to track the channel variations. Such an equalizer is called an adaptive equalizer since it adapts to the channel variations.

### **9. What is training mode in an adaptive equalizer?**

First, a known fixed length training sequence is sent by the transmitter, then the receiver's equalizer may adapt to a proper setting of minimum bit error rate detection, where the training sequence is pseudorandom binary signal or a fixed and prescribed bit pattern.

### **10. What is tracking mode in an adaptive equalizer?**

Immediately following the training sequence, the user data is sent, and the adaptive equalizer at the receiver utilizes a recursive algorithm to evaluate the channel and estimate filter coefficients to compensate for the distortion created by multipath in the channel.

### **11. Write a short note on i) linear equalizers      ii) non-linear equalizers**

If the output is not used in the feedback path to adapt, then this type of equalizer is called linear equalizer. If the output is fed back to change the subsequent outputs of the equalizer, this type of equalizer is called nonlinear equalizers.

### **12. Write the advantages of lattice equalizer.**

It is simplest and easily available, Numerical stability, Faster convergence, Unique structure of the lattice filter allows the dynamic assignment of the most effective length of the lattice equalizer and When the channel becomes more time dispersive, the length of the equalizer can be increased by the algorithm without stopping the operation of the equalizer.

### **13. Why nonlinear equalizers are preferred?**

The linear equalizers are very effective in equalizing channels where ISI is not severe. The severity of ISI is directly related to the spectral characteristics. In this case there are spectral nulls in the transfer function of the effective channel; the additive noise at the receiver input will be dramatically enhanced by the linear equalizer. To overcome this problem, nonlinear equalizers can be used.

### **14. What are the nonlinear equalization methods used?**

Decision feedback equalization (DFE), Maximum likelihood symbol detection and Maximum likelihood sequence estimation (MLSE).

### **15. Where DFEs are used?**

DFE is particularly useful for channels with severe amplitude distortions and is widely used in wireless communications.

**16. Define rate of convergence.**

The no of iterations required for the algorithm in response to stationary inputs to converge close enough to the optimum solution.

**17. Write the advantages of LMS algorithm.**

It maximizes the signal to distortion at its output within the constraints of the equalizer filter length, Low computational complexity and Simple program

**18. What is the need for diversity schemes?**

To increase signal to noise ratio, for error free digital transmission, to degrade the bit error probability.

**19. Explain Diversity concept.**

If one radio path undergoes a deep fade, another independent path may have a strong signal. By having more than one path to select from, both the instantaneous and average SNRs at the receiver may be improved.

**20. List out the four types of Combining Methods.**

Selection combining, switched combining, Equal gain combining, Maximum ratio combining. **21. Differentiate between Macrodiversity and Microdiversity. (Dec 2014)**

<b>Macrodiversity</b>	<b>Microdiversity</b>
<p>In antenna (or from locations are combined</p> <p>micro) diversity the antennas mounted at separate locations are combined</p>	<p>In site (or macro) diversity the signal receiving antennas are located at different receiver sites</p>
<p>These antennas are located on the vehicle or at the same base station tower and their spacing is a few wavelengths. The received signal amplitude is correlated, depending on the separation <math>d</math> relative to the wavelength.</p>	<p>Signals from within a cell may be received at the different corners of the hexagonal area.</p> <p>The advantage is that not only the multipath fading attenuation is independent at each branch but that the shadowing and losses are also uncorrelated to some extent</p>

**22. What are the benefits of Rake Receiver? (May 2016).**

1. Rake receiver gives the best performance among all the CDMA receivers.
2. Since correlators form the main working system of the receiver. The best version of the received signal is selected and given as output.

**23. State the principle of diversity.(June 2013)**

Diversity: It is the technique used to compensate for fading channel impairments. It is implemented by using two or more receiving antennas. While Equalization is used to counter the effects of ISI, Diversity is usually employed to reduce the depth and duration of the fades experienced by a receiver in a flat fading channel. These techniques can be employed at both base station and mobile receivers. Spatial Diversity is the most widely used diversity technique.

**24. What are the benefits of Rake Receiver? (May 2016).**

1. Rake receiver gives the best performance among all the CDMA receivers.
2. Since correlators form the main working system of the receiver. The best version of the received signal is selected and given as output.

**25. Draw the structure of a linear transversal equaliser (Dec 2015)**

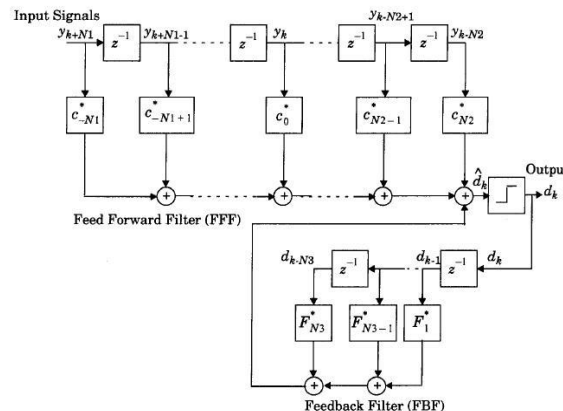

**PART B**

1. Explain the classification of equalizers.
2. Briefly explain about linear and non-linear equalizers.(Dec 2013)(May 2016).
3. Discuss about DFE.
4. Explain about MLSE equalizer.(Dec 2013)

5. Discuss in detail about the different micro diversity concepts. **(May 2016).**
6. Explain about theoretical model for polarization diversity.
7. Discuss the performance of a RAKE receiver with a neat diagram. **(Dec 2013)**
8. Explain any two diversity techniques to combat small scale fading **(June 2013)**
9. Describe any two adaptation algorithms for Mean square error Equalizers **(June 2013)**
10. (i) With a neat block diagram explain the principle of Macro diversity  
 (ii) Explain the operation of an adaptive equalizer at the receiver side **(Dec 2014)**
11. (i) Explain with block diagram Maximal ratio combiner  
 (ii) Describe on Polarization and space diversity. **(Dec 2014)**
12. Derive the mean square error for a generic adaptive equaliser **(Dec 2015).**

## UNIT V MULTIPLE ANTENNA TECHNIQUES

### PART A

#### **1. What is Beamforming?**

The multiple antennas at the transmitter and receiver can be used to obtain array and diversity gain instead of capacity gain. In this setting the same symbol weighted by a complex scale factor is sent over each transmit antenna, so that the input covariance matrix has unit rank. This scheme is also referred to as MIMO beamforming.

#### **2. What are the advantages of Beamforming?**

Beamforming provides diversity and array gain via coherent combining of the multiple signal paths.

#### **3. What is multiplexing gain?**

Multiple antennas are used to improve wireless system performance. One option is to obtain capacity gain by decomposing the MIMO channel into parallel channels and multiplexing different data streams onto these channels. This capacity gain is also referred to as multiplexing gain.

#### **4. Define Transmitter diversity. (May 2016).**

In transmit diversity there are multiple transmit antennas, and the transmit power is divided among these antennas. Transmit diversity is desirable in systems where more space, power, and processing capability is available on the transmit side than on the receive side. Transmit diversity design depends on whether or not the complex channel gain is known to the transmitter.

#### **5. What is RAKE receiver?**

A more complicated receiver can have several branches, with each branch synchronized to a different multipath component. This structure is called a RAKE receiver, and it assumes there is a multipath component at each integer multiple of a chip time.

**6. Write the advantages of RAKE receiver.**

RAKE's provide a simple mechanism to obtain diversity benefits. When spread spectrum signalling is chosen for its other benefits such as multiuser or interference rejection capabilities.

**7. Explain the concept of Rake receiver.**

In Multipath environment, if the multiple versions of the signal arrive more than one chip interval apart from each other. The receiver can recover the signal from multiple paths and then combine them with suitable delays. This method achieves better performance than simply recovering dominant signal and treating remaining signals as noise.

**8. What are MIMO systems?(May 2016).**

Systems with multiple antennas at the transmitter and receiver, which are commonly referred to as multiple-input multiple-output (MIMO) systems. The multiple antennas can be used to increase data rates through multiplexing or to improve performance through diversity.

**9. Draw the MIMO model.**

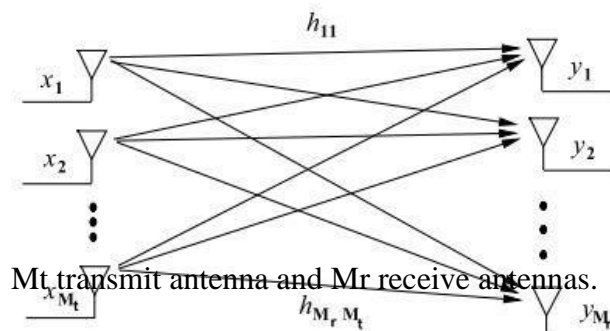

**10. Write the advantages of MIMO systems.**

- i. Multiple-input multiple-output systems can significantly enhance performance of wireless systems through multiplexing or diversity gain.
  - ii. For a given transmit energy per bit, multiplexing gain provides a higher data rate whereas diversity gain provides a lower BER in fading.
  - iii. Support a higher data rate for a given energy per bit, so it transmits the bits more quickly and can then shut down to save energy.

**11. Write the disadvantages of MIMO systems.**

- i. MIMO systems entail significantly more circuit energy consumption than their single antenna counterparts, because separate circuitry is required for each antenna signal path.



- ii. Signal processing associated with MIMO can be highly complex. **12. Mention the applications of MIMO systems.**
- i. MIMO can reliably connect devices in home, such as computer networking devices, cabled video devices, phone lines, music, storage devices etc.
- ii. The IEEE 802.16e standard and the IEEE 802.11n standard also use MIMO system.
- iii. MIMO is used in mobile radio telephone standard such as 3GPP and 3GPP2 standard.

3GPP High Speed Packet Access Plus (HSPA+) and Long Term Evolution (LTE) standard use MIMO.

### **13. How does spatial multiplexing work?**

Spatial multiplexing uses MEA's (Multiple element antennas) at the transmitter for transmission of data streams. An original high-rate DataStream is multiplexed into several parallel streams, each of which is sent from one transmit antenna element. The channel mixes up these data streams so that each of the receive antenna elements sees a combination of them.

### **14. State the importance of spatial multiplexing.**

The basic premise of spatial multiplexing is to send  $M_t$  independent symbols per symbol period using the dimensions of space and time. To obtain full diversity order, an encoded bit stream must be transmitted over all  $M_t$  transmit antennas. This can be done through serial encoding.

### **15. What is transmit diversity?**

In transmit diversity more antennas are used on the transmitter side than on the receiver

side. Transmit diversity is used to reduce the effect of fading. In transmit diversity the same information is transmitted from two different antennas. Data from the second antenna is encoded differently to differentiate it from the first antenna. This can be done to enable the user equipment on the receiver side to identify that the information is coming from the different locations and properly decode it. Space-time coding is used to create redundant signals.

### **16. What are smart antennas and MIMO systems?**

A MIMO system consists of several antenna elements, plus adaptive signal processing at both transmitter and receiver, the combination of which exploits the spatial dimension of the mobile radio channel. A smart antenna system is a system that has multiple antenna elements only at one link end.

### **17. What is array gain?**

Array gain is defined as the average increase in the SNR and depends on the number of transmit and receive antennas. Transmit/Receive array gain needs channel information in the transmitter and receiver respectively. Channel information is typically available in the receiver whereas the channel state information in the transmitter is more difficult to maintain in general.

### **18. What is diversity gain?**

Diversity is a powerful technique to reduce fading effect in wireless communications. Diversity gain is

defined as the reduction in the probability of error due to multiple independent paths produced between the transmitter and receiver. In other words if there are  $M$  transmit,  $N$  receive antennas, the order of diversity is  $M \cdot N$ . There is no diversity gain if the medium is line of sight channel.

### **19. What is multiplexing gain?**

Multiplexing gain is defined as the increase in the data rate; since independent data streams are sent through independent paths between multiple transmitters and multiple receivers. In other words if there are  $M$  ( $> 1$ ) transmit antennas and  $N$  ( $> 1$ ) receive antennas, the increase in the data rate is  $\min(M, N)$ -fold

### **20. What is meant by co-phasing?**

**“Co-phase the signals” means that we need to multiply signals by  $e^{j\phi_i}$  for some constant phase angle  $\phi_i$  on channel  $i$ , so that the (otherwise random) phases of the signals on the different channels line up. If we don't**

co-phase the signals before combining them, we end up with the multipath fading problem signals sometimes add together destructively. Without co-phasing, the branch signals would not add up coherently in the combiner, so the resulting output could still exhibit significant fading due to constructive and destructive addition of the signals in all the branches.

### **21. Describe threshold combining.**

Selection combining for systems that transmit continuously may require a dedicated receiver on each branch to continuously monitor branch SNR. A simpler type of combining, called threshold combining,

avoids the need for a dedicated receiver on each branch by scanning each of the branches in sequential **order and outputting the first signal whose SNR is above a given threshold  $\gamma_T$** . **As in SC, co-phasing is not**

required because only one branch output is used at a time. Hence this technique can be used with either coherent or differential modulation.

### **22. Define channel capacity of MIMO system.**

A very important factor for the profitability of a wireless network is its capacity. MIMO system provides high capacity by using multiple antennas at both the transmitter and receiver end of the radio link. Multiple antennas are used to improve the capacity over SISO system when operated in multi-path environment. MIMO system capacity is measured in bits per second per hertz and is bounded by Shannon-Hartley capacity. But it has become apparent that MIMO system can exceed the Shannon-Hartley limit of SISO depending on the channel properties and the number of antennas.

### 23. What is Precoding.

Pre-coding is generalized to allow multi-layer transmission in MIMO systems. As conventional beamforming considers as linear single layer pre-coding, increasing the signal power at the output of the receiver by emitting the same signal from each of the transmit antennas with suitable weighting. When multiple antennas are used at the receiver, the signal levels are maximized simultaneously at all of the

multiple receive antennas, so in that case pre-coding is used for multi-layer beamforming to increase the throughput performance of a multiple receive antennas. In pre-coding the transmit antennas transmit the multiple streams with independent and suitable weighting per antenna such that higher link throughput is obtained at the receiver output

### 24. What is Alamouti's scheme?

**Alamouti's scheme is designed for a digital communication system with two-antenna.** Transmit diversity. The scheme works over two symbol periods and it is assumed that the Channel gain is constant over this time. Over the first symbol period, two different symbols  $S_1$  and  $S_2$  (each with energy  $E_s/2$ ) are transmitted simultaneously from antennas 1 and 2, **respectively. Over the next symbol period, symbol  $-S_2^*$  is**

transmitted from antenna 1 and symbol  $S_1^*$  is transmitted from antenna 2, each again with symbol energy  $E_s/2$ .

### 25. What is Antenna Diversity? (Dec 2015)

Antenna Diversity or Space Diversity or Spatial Diversity can be given as the diversity scheme followed in wireless communications to overcome multipath fading. More than one antenna are used for transmission and reception, and the main concept behind this method is the signals transmitted by different antennas undergo different fading and there is at least one robust version of the signal being received. This method requires more sophisticated hardware for synchronisation.

## **PART B**

1. Briefly explain Multiple-input multiple output systems.
2. Explain Pre-coding and Beam forming.
3. Define Beamforming and briefly explain MIMO diversity gain. **(May 2016).**
4. Discuss transmit diversity with channel known at transmitter.
5. Discuss transmit diversity with channel unknown at transmitter – The Alamouti scheme.
6. Explain receiver diversity in detail.
7. Discuss receiver diversity with selection combining and threshold combining.

8. Briefly discuss Maximal-Ratio combining and Equal-Gain combining.
9. Discuss the capacity of time-varying frequency-selective fading channels with respect to time-invariant channels and time-varying channels.
10. Discuss the capacity in fading and unfading channels.
11. Explain parallel decomposition of the MIMO channel.
12. Explain the architectures of spatial multiplexing with neat diagram. **(May 2016).**
13. Determine the capacity of frequency selective fading and explain the concept of water filling/water pouring models. **(Dec 2015).**
14. Explain with relevant diagrams the layered space time structure with respect to MIMO systems. **(May 2016).**

## **IT6503-WEB PROGRAMMING**

### **UNIT 1- SCRIPTING**

#### **1. What is HTML?**

HTML is a language for describing web pages.

HTML stands for **H**yper **T**ext **M**arkup **L**anguage

HTML is not a programming language, it is a **markup language**

A markup language is a set of **markup tags**

HTML uses **markup tags** to describe web pages

#### **2. How to implement the HTML Links**

HTML links are defined with the <a> tag.

```
<a href="http://www.w3schools.com">This is a link</a>
```

#### **3. Define HTML Tables**

Tables are defined with the <table> tag. A table is divided into rows (with the <tr> tag), and each row is divided into data cells (with the <td> tag). td stands for "table data," and holds the content of a data cell. A <td> tag can contain text, links, images, lists, forms, other tables, etc.

#### **4. How to declare the HTML Forms**

HTML forms are used to pass data to a server. A form can contain input elements like text fields, checkboxes, radio-buttons, submit buttons and more. A form can also contain select lists, textarea, fieldset, legend, and label elements. The <form> tag is used to create an HTML form:

```
<form> .input elements .</form>
```

#### **5. What is Document type declaration(DTD)**

HTML documents are required to start with a Document Type Declaration (informally, a "doctype"). In browsers, the doctype helps to define the rendering mode—particularly whether to use quirks mode. An example of an HTML 4 doctype is

```
<!DOCTYPE HTML PUBLIC "-//W3C//DTD HTML 4.01//EN"
```

```
"http://www.w3.org/TR/html4/strict.dtd">
```

## 6. Compare SGML-based versus XML-based HTML

The XML-based specification is usually called XHTML to distinguish it clearly from the more traditional definition. However, the root element name continues to be 'html' even in the XHTML-specified HTML. The W3C intended XHTML 1.0 to be identical to HTML 4.01 except where limitations of XML over the more complex SGML require workarounds. Because XHTML and HTML are closely related, they are sometimes documented in parallel.

## 7. What is SGML ?Standard Generalized Markup Language

- HTML is an instance of SGML.
- SGML was invented beginning in the mid-1970s by Charles Goldfarb at IBM
- SGML is now an International Standards Organization (ISO) standard, specifically ISO 8879:1986.
- SGML allows the user to create various user defined tags easily without any rules.

## 8. Mention the different types of links

- HTML allows linking to other HTML documents as well as images. There are 3 attributes that can be introduced in BODY tag.
- LINK – Changes the default color of a Hyperlink to whatever color is specified with this tag.
- ALINK – Changes the default color of a hyperlink that is activated to whatever color is specified with this tag.
- VLINK – Changes the default color of a hyperlink that is already visited to whatever color is specified with this tag.
- NOTE: User can specify the color name of a hyperlink or an equivalent hexadecimal number.

### EXTERNAL LINKS

#### SYNTAX

```
<A HREF = —location name‖> Hyper Text Message </A>
```

## 9. How do you change the color of background or text in HTML?

Include the element \"bgcolor\" with a color code in your body tag:

```
<BODY BGCOLOR=\"#ffffff\" TEXT=\"#000000\" LINK=\"#cc0000\"  
VLINK=\"#000066\" ALINK=\"#ffff00\">
```

## 10. How do you use a picture as the background in HTML?

Include the element \"background\" with the name of the graphics file:

```
<BODY BACKGROUND=\"gumby.gif\" BGCOLOR=\"#ffffff\" TEXT=\"#000000\"  
LINK=\"#cc0000\" VLINK=\"#000066\" ALINK=\"#ffff00\">
```

## 11. How do you add music to a web page?

```
<A HREF=\"http://www.snowhawk.com/sounds/hvnearth.mid\">Heaven on Earth</A>
```

## 12. How do you align text next to a graphic in HTML?

```
<IMG SRC=\"wflower.jpg\" WIDTH=\"25\" HEIGHT=\"25\" ALIGN=\"top\" BORDER=\"0\"  
ALT=\"wildflower photo\"> Photo of wildflowers in Texas</A>
```

### **13. How do you make a graphic a link?**

```
<A HREF="http://www.snowhawk.com/wildlife.html"><IMG SRC="leopard.jpg"
WIDTH="25" HEIGHT="25" ALIGN="top" BORDER="0" ALT="link to
wildlife"></A>
```

### **14. What is CSS?**

Cascading Style Sheets (CSS) is a slightly misleading term, since a website might have only one CSS file (style sheet), or the CSS might be embedded within an HTML file. It is better to think of CSS as a technology (in the singular). CSS is comprised of statements that control the styling of HTML documents. Simply put, an HTML document should convey content. A CSS document should control the styling of that content.

### **15. What is the purpose of CSS Box Model and mention its parts also.**

The CSS box model is essentially a box that wraps around HTML elements, and it consists of: margins, borders, padding, and the actual content.

The different parts are:

- Margin
- Border
- Padding
- Content

### **16. What is JavaScript?**

JavaScript was designed to add interactivity to HTML pages

JavaScript is a scripting language

A scripting language is a lightweight programming language

A JavaScript consists of lines of executable computer code

A JavaScript is usually embedded directly into HTML pages

### **17. Are Java and JavaScript the Same?**

NO!. Java and JavaScript are two completely different languages in both concept and design. Java (developed by Sun Microsystems) is a powerful and much more complex programming language - in the same category as C and C++.

### **18. How to put a JavaScript into an HTML Page ?**

```
<html>
<body>
<script type="text/javascript">
document.write("Hello World!");
</script>
</body>
</html>
```

### **19. What are literals?**

Literal values are the ones you type into mathematical or string expressions. For example 23 (an integer), 12.32E23 (a floating point), or 'flopsy the Hamster' (a string).

String literals can be enclosed by either single or double quotes. For example:

'literal string'

"literal string"

'literal string with "double quotes" inside'

## **20. Mention the advantages of java/java script**

- Use sending data continuously File storage Massively parallel computing
- Smart forms – includes various controls like text box, radio button, textc. area control etc.
- Peer-to-Peer Interaction – used in various client/server model.
- Games – Combine the ability to easily include networking in your programs with java's powerful graphics and you have the recipe for truly awesome multiplayer games.
- Chat – Used in various chat applications.f.
- Whiteboards – Java programs are not limited to sending ext and datag. across the network.
- h. A number of programmers have developed whiteboard software that allows users in diverse locations to draw on their computers

## **21. What are Style Sheets?**

Style sheets are collections of style information that are applied to plain text. Style information includes font attributes such as type size, special effects (bold,italic,underline), color and alignment. Style sheets also provide broader formatting instructions by specifying values for quantities such as line spacing and left and right margins.

## **22. List down the ways of including style information in a document.**

1. Linked Styles -Style information is read from a separate file that is specified in the <LINK> tag
2. Embedded Styles -Style information is defined in the document head using the <STYLE> and </STYLE> tags.
3. Inline Styles -Style information is placed inside an HTML tag and applies to all content between that tag and it companion closing tag.

## **23. Define cascading.**

Cascading refers to a certain set of rules that browsers use, in cascading order, to determine how to use the style information. Such a set of rules is useful in the event of conflicting style information because the rules would give the browser a way to determine which style is given precedence.

## **24. What are the style precedence rules when using multiple approaches?**

Inline styles override both linked style sheets and style information stored in the document head with <STYLE> tag.

Styles defined in the document head override linked style sheets.

Linked style sheets override browser defaults.

## **25. Give the syntax to specify a characteristic in linked style sheet.**

{Characteristic: value}

Multiple characteristic/value pairs should be separated by semicolons.

**26. List down font characteristics permitted in style sheets.**

1. font-family
2. font-size
3. font-weight
4. font-style
5. font-variant

**27. Write a note on content positioning characteristic \"Visibility\".**

Enables the document author to selectively display or conceal positioned content; Possible values are show or hide.

**28. Define scriptlets.**

Scriptlets enable you to create small, reusable web applications that can be used in any web page. Scriptlets are created using HTML, scripting and Dynamic HTML. To include them in an HTML document use the <OBJECT> tag.

**29. What does DHTML refer?**

DHTML refers to collection of technologies, which makes HTML documents more dynamic and interactive.

**30. What does data binding mean?**

Data binding is DHTML feature that lets you easily bind individual elements in your document to data from another source such as database or comma delimited text file.

**31. What is meant by Plug-in?**

A hardware or software module that adds a specific feature or service to a larger system. The idea is that the new component simply plugs in to the existing system. For example, there are number of plug-ins for the Netscape Navigator browser that enable it to display different types of audio or video messages. Navigator plug-ins are based on MIME filetypes.

**32. Mention The Types Of Scripting Languages**

- JavaScript is a Scripting language (web site development environment) created by Netscape.
- Hence JavaScript works best with the Netscape suite of Client and Server products.
- JavaScript is the native scripting language of Netscape Navigator.
- VBScript is the native Scripting language of HTML.

**33. What is Server Side Scripting?**

- In Server side scripting the script program is executed at Server Side the required html program is sent to the client.
- The job of the server is more in server side scripting

**34. What is Client Side Scripting?**

- Here the script program is processed and executed in the client side itself.
- So that it reduces the burden of the server.

**35. Mention few Advantages of Java Script**



- It is an interpreted language, which requires no compilation steps.
- Embedded within HTML.
- Minimal Syntax – easy to learn
- Quick Development
- Designed for simple, small programs
- High performance
- Procedural Capabilities – support facilities such as condition checking, looping and branching.
- Designed for programming user events – like VB Java Script is also based on Events.
- Easy Debugging and Testing
- Platform Independence/ Architecture Neutral

### **36. Mention The Various Java Script Object Models .**

- Math Object
- String Object
- Date Object
- Boolean and Number Object
- Document Object
- Window Object

### **37. How Scripting Language Is Differs From Html ?**

- HTML is used for simple web page design
- HTML with FORM is used for both form design and Reading input values from user.
- Scripting Language is used for Validating the given input values weather it is correct or not, if the input value is incorrect, the user can pass an error message to the user.
- Using form concept various controls like Text box, Radio Button, Command Button, Text Area control and List box can be created.

### **38. Define Function In Java Script .**

Function is a part of a program or in other words function is a module in java program which can be called or invoked any number of times from the main program.

Function can be called any number of times but it can accept any input values or parameters, however it can return only one output at a time

### **39. How To Introduce Style In Html Program?**

<HTML>

<HEAD>

<STYLE Type = —text/css||>

predefined tag name {attribute name1:attribute value1; attribute name2:attribute value2; .....attribute name-n:attribute value-n}

<STYLE>

</HEAD>

<BODY>

write the body of program

</BODY> </HTML>

## Part - B

### **1. Explain the Fundamental HTML Elements**

- What is HTML?
- HTML Tags
- HTML Documents
- HTML Elements
- HTML Element Syntax
- Nested HTML Elements
- HTML Document Example
- EMPTY HTML ELEMENTS
- HTML Attributes
- HTML HEADINGS
- HTML Formatting Tags

### **2. Explain the various methodologies by which you can retrieve data from Internet.**

Internet Search Engine

Protocols used to retrieve the Data

i)FTP –Concepts

Commands &Semantics

Anonymous FTP

ii)TELNET

Network Virtual Terminal

Commands \*Control Functions

Negotiable Options

iii)HTTP

iv)TFTP

### **3. Explain about <TABLE> &<FRAME> tags in Detail.**

Code for Basic HTML Table

```
<TABLE>
```

```
<TR>-----</TR> <!--Row1-->
```

```
<TR>-----</TR> <!--Row2-->
```

```
-----
```

```
<TR>-----</TR> <!--Rowm-->
```

```
</TABLE>
```

Creating a Table cell.

i)Header cell

ii)Data cell

Table Alifnment

i)Aligning the Entire Table

ii)Alignment within a row.

ii) Alignment within a cell.

Spanning Multiple Rows & Columns

<FRAMES>

Creating the <FRAMESET> tag

Creating the <FRAME> tag

Eg:<FRAMESET Rows="10%,80%,10%">

<FRAME name="top" src="a.html">

<FRAME name="mid"src="b.html">

<FRAME name="bot" src="c.html">

</FRAMESET>

#### 4. Discuss the various HTML tags in detail.

[<html>](#)

[<img>](#)

[<b>](#)

[<base>](#)

[<base font>](#)

[<i>](#)

[<big>](#)

[<body>](#)

[<br>](#)

[<button>](#)

[<caption>](#)

[<center>](#)

[<dd>](#)

[<dialog>](#)

[<dir>](#)

[<div>](#)

[<dl>](#)

[<dt>](#)

[<em>](#)

#### 5. CSS Background Properties

| Property                     | Description   | Values   | CSS |
|------------------------------|---|--|-----|
| <u>background</u>            | Sets all the background properties in one declaration                         | background-color<br>background-image<br>background-repeat<br>background-attachment<br>background-position<br>inherit | 1   |
| <u>background-attachment</u> | Sets whether a background image is fixed or scrolls with the rest of the page | Scroll, fixed, inherit   | 1   |

|                            |  |   |   |
|----------------------------|--|---|---|
| <u>background-color</u>    | Sets the background color of an element          | color-rgb<br>color-hex<br>color-name<br>transparent<br>inherit  | 1 |
| <u>background-image</u>    | Sets the background image for an element         | url(URL),none,inherit   | 1 |
| <u>background-position</u> | Sets the starting position of a background image | left top<br>left center<br>left bottom<br>right top<br>right center<br>right bottom<br>center top<br>center center<br>center bottom | 1 |
| <u>background-repeat</u>   | Sets if/how a background image will be repeated  | Repeat,repeat-x<br>repeat-y,no-repeat,inherit   | 1 |

## 6. Types of CSS.

There are three ways of inserting a style sheet:

- External style sheet
- Internal style sheet
- Inline style

## 7. Explain the various event handlers in java script. Give an example.

| Event       | Description                                   |
|-------------|---|
| onchange    | An HTML element has been changed              |
| onclick     | The user clicks an HTML element               |
| onmouseover | The user moves the mouse over an HTML element |

|            |  |
|------------|--|
| onmouseout | The user moves the mouse away from an HTML element |
| onkeydown  | The user pushes a keyboard key                     |
| onload     | The browser has finished loading the page          |

**8. List out objects available in JavaScript.**

- Math
- String
- Date
- document
- window
- cookies.

**9. Explain in detail about Text properties.**

- Font families.
- Length specifications in CSS.
- Font properties.
- Line boxes.
- Text formatting and color.

**10. Explain the Normal flow box layout in detail.**

- Basic box layout.
- Display property.
- Margin collapse.
- Block box width and height.
- Simple inline boxes.
- Nested inline boxes.

**11. Discuss the beyond the normal flow.**

- Properties for positioning.
- Relative positioning.
- Float positioning.
- Absolute positioning.
- Positioning related properties.

## UNIT II- JAVA

1. What is meant by Object Oriented Programming?

**OOP is a method of programming in which programs are organised as cooperative collections of objects. Each object is an instance of a class and each class belong to a hierarchy.**

2. What is a Class?

**Class is a template for a set of objects that share a common structure and a common behaviour.**

### **3. What is an Object?**

Object is an instance of a class. It has state, behaviour and identity. It is also called as an instance of a class.

### **4. What is an Instance?**

An instance has state, behaviour and identity. The structure and behaviour of similar classes are defined in their common class. An instance is also called as an object.

### **5. What are the core OOP's concepts?**

Abstraction, Encapsulation, Inheritance and Polymorphism are the core OOP's concepts.

### **6. What is meant by abstraction?**

Abstraction defines the essential characteristics of an object that distinguish it from all other kinds of objects. Abstraction provides crisply-defined conceptual boundaries relative to the perspective of the viewer. It's the process of focussing on the essential characteristics of an object. Abstraction is one of the fundamental elements of the object model.

### **7. What is meant by Encapsulation?**

Encapsulation is the process of compartmentalising the elements of an abstraction that defines the structure and behaviour. Encapsulation helps to separate the contractual interface of an abstraction and implementation.

### **8. What are Encapsulation, Inheritance and Polymorphism?**

Encapsulation is the mechanism that binds together code and data it manipulates and keeps both safe from outside interference and misuse. Inheritance is the process by which one object acquires the properties of another object. Polymorphism is the feature that allows one interface to be used for general class actions.

### **9. What are methods and how are they defined?**

Methods are functions that operate on instances of classes in which they are defined. Objects can communicate with each other using methods and can call methods in other classes. Method definition has four parts. They are name of the method, type of object or primitive type the method returns, a list of parameters and the body of the method. A method's signature is a combination of the first three parts mentioned above.

### **10. What are different types of access modifiers (Access specifiers)?**

Access specifiers are keywords that determine the type of access to the member of a class. These keywords are for allowing privileges to parts of a program such as functions and variables. These are: *public*: Any thing declared as public can be accessed from anywhere. *private*: Any thing declared as private can't be seen outside of its class.

*protected*: Any thing declared as protected can be accessed by classes in the same package and subclasses in the other packages.

*default modifier* : Can be accessed only to classes in the same package.

### **11. What is an Object and how do you allocate memory to it?**

Object is an instance of a class and it is a software unit that combines a structured set of data with a set of operations for inspecting and manipulating that data. When an object is created using new operator, memory is allocated to it.

### **12. Write the usage of Java packages.**

This is a way to organize files when a project consists of multiple modules. It also helps resolve naming conflicts when different packages have classes with the same names. Packages access level also allows you to protect data from being used by the non-authorized classes.

### **13. What is method overloading and method overriding?**

Method overloading: When a method in a class having the same method name with different arguments is said to be method overloading. Method overriding : When a method in a class having the same method name with same arguments is said to be method overriding.

### **14. What gives java it's "write once and run anywhere" nature?**

All Java programs are compiled into class files that contain bytecodes. These byte codes can be run in any platform and hence java is said to be platform independent.

### **15. What is a constructor? What is a destructor?**

**Constructor is an operation that creates an object and/or initialises its state. Destructor is an operation that frees the state of an object and/or destroys the object itself. In Java, there is no concept of destructors. Its taken care by the JVM.**

### **16. What is the difference between constructor and method?**

**Constructor will be automatically invoked when an object is created whereas method has to be called explicitly**



**17. What is Static member classes?**

A static member class is a static member of a class. Like any other static method, a static member class has access to all static methods of the parent, or top-level, class.

**18. What is Garbage Collection and how to call it explicitly?**

When an object is no longer referred to by any variable, java automatically reclaims memory used by that object. This is known as garbage collection. System. gc() method may be used to call it explicitly

**19. In Java, How to make an object completely encapsulated?**

All the instance variables should be declared as private and public getter and setter methods should be provided for accessing the instance variables.

**20. What is static variable and static method?**

static variable is a class variable which value remains constant for the entire class

static method is the one which can be called with the class itself and can hold only the static variables.

**21. What is finalize() method?**

finalize () method is used just before an object is destroyed and can be called just prior to garbage collection.

**22. What is the difference between String and StringBuffer?**

a) String objects are constants and immutable whereas StringBuffer objects are not. b) String class supports constant strings whereas StringBuffer class supports growable and modifiable strings.

**23. What is the difference between Array and vector?**

Array is a set of related data type and static whereas vector is a growable array of objects and dynamic

**24. What is a package?**

A package is a collection of classes and interfaces that provides a high-level layer of access protection and name space management.

**25. What is the difference between this() and super()?**

this() can be used to invoke a constructor of the same class whereas super() can be used to invoke a super class constructor.

## **26. What is meant by Inheritance and what are its advantages?**

Inheritance is the process of inheriting all the features from a class. The advantages of inheritance are reusability of code and accessibility of variables and methods of the super class by subclasses.

## **27. What is the difference between superclass and subclass?**

A super class is a class that is inherited whereas sub class is a class that does the inheriting.

## **28. What is meant by Polymorphism?**

Polymorphism literally means taking more than one form. Polymorphism is a characteristic of being able to assign a different behavior or value in a subclass, to something that was declared in a parent class.

## **29. What is an Abstract Class?**

Abstract class is a class that has no instances. An abstract class is written with the expectation that its concrete subclasses will add to its structure and behaviour, typically by implementing its abstract operations.

## **30. What are inner class and anonymous class?**

Inner class: classes defined in other classes, including those defined in methods are called inner classes. An inner class can have any accessibility including private. Anonymous class: Anonymous class is a class defined inside a method without a name and is instantiated and declared in the same place and cannot have explicit constructors

## **31. What is interface and write its use.**

Interface is similar to a class which may contain method's signature only but not bodies and it is a formal set of method and constant declarations that must be defined by the class that implements it. Interfaces are useful for: a) Declaring methods that one or more classes are expected to implement b) Capturing similarities between unrelated classes without forcing a class relationship. c) Determining an object's programming interface without revealing the actual body of the class.

## **32. How is polymorphism achieved in java?**

Inheritance, Overloading and Overriding are used to achieve Polymorphism in java.

### **Part –B**

#### **1. Explain the features of Java.**

1. Simple
2. Object-Oriented
3. Platform independent
4. Secured

5. Robust
6. Architecture neutral
7. Portable
8. Dynamic
9. Interpreted
10. High Performance
11. Multithreaded
12. Distributed

## 2. Describe the structure of Java program.

- A program is made up of one or more *classes*
- A class contains one or more *methods*
- A method contains program *statements*

A Java application always contains a method called main

## 3. Write about the control statements in Java .

Java has very flexible three looping mechanisms. You can use one of the following three loops:

- while Loop
- do...while Loop
- for Loop

## 4. Write a Java program to perform matrix operations.

```
import java.util.Scanner;
```

```
public class MatrixAddition {
```

```
    public static void main(String[] args) {
        Scanner s = new Scanner(System.in);
        System.out.print("Enter number of rows: ");
        int rows = s.nextInt();
        System.out.print("Enter number of columns: ");
        int columns = s.nextInt();
        int[][] a = new int[rows][columns];
        int[][] b = new int[rows][columns];
        System.out.println("Enter the first matrix");
        for (int i = 0; i < rows; i++) {
            for (int j = 0; j < columns; j++) {
                a[i][j] = s.nextInt();
            }
        }
        System.out.println("Enter the second matrix");
        for (int i = 0; i < rows; i++) {
```

```

        for (int j = 0; j < columns; j++) {
            b[i][j] = s.nextInt();
        }
    }
    int[][] c = new int[rows][columns];
    for (int i = 0; i < rows; i++) {
        for (int j = 0; j < columns; j++) {
            c[i][j] = a[i][j] + b[i][j];
        }
    }
    System.out.println("The sum of the two matrices is");
    for (int i = 0; i < rows; i++) {
        for (int j = 0; j < columns; j++) {
            System.out.print(c[i][j] + " ");
        }
        System.out.println();
    }
}
}

```

Here is a sample execution.

```

Enter number of rows: 2
Enter number of columns: 3
Enter the first matrix
3 4 7
1 8 4
Enter the second matrix
3 2 1
1 0 4
The sum of the two matrices is
6 6 8
2 8 8

```

### **5.Explain the concept of inheritance with suitable example.**

**Inheritance in java** is a mechanism in which one object acquires all the properties and behaviors of parent object.

Single inheritance

Multitple inheritance

Multilevel inheritance

Hybrid inheritance

## 6. What is a package? Write down the steps in creating a package and using it in Java program with an example.

A Package can be defined as a grouping of related types (classes, interfaces, enumerations and annotations) providing access protection and name space management.

Some of the existing packages in Java are::

- **java.lang** - bundles the fundamental classes
- **java.io** - classes for input, output functions are bundled in this package

### Creating a package:

The **package** statement should be the first line in the source file. There can be only one package statement in each source file, and it applies to all types in the file.

Put an interface in the package *animals*:

```
/* File name : Animal.java */  
  
package animals;  
  
interface Animal {  
    public void eat();  
    public void travel();  
}
```

Now, put an implementation in the same package *animals*:

```
package animals;  
  
/* File name : MammalInt.java */  
  
public class MammalInt implements Animal{  
  
    public void eat(){  
        System.out.println("Mammal eats");  
    }  
}
```

```

public void travel(){
    System.out.println("Mammal travels");
}

public int noOfLegs(){
    return 0;
}

public static void main(String args[]){
    MammalInt m = new MammalInt();
    m.eat();
    m.travel();
}
}

```

Now, you compile these two files and put them in a sub-directory called **animals** and try to run as follows:

```

$ mkdir animals
$ cp Animal.class MammalInt.class animals
$ java animals/MammalInt
Mammal eats
Mammal travels

```

### **7.Explain the concept of interface with suitable example.**

An interface is a collection of abstract methods. A class implements an interface, thereby inheriting the abstract methods of the interface.

#### **Declaring Interfaces:**

The **interface** keyword is used to declare an interface. Here is a simple example to declare an interface:

### Example:

Let us look at an example that depicts encapsulation:

```
/* File name : NameOfInterface.java */
import java.lang.*;
//Any number of import statements

public interface NameOfInterface
{
    //Any number of final, static fields
    //Any number of abstract method declarations\
}
```

Interfaces have the following properties:

- An interface is implicitly abstract. You do not need to use the **abstract** keyword when declaring an interface.
- Each method in an interface is also implicitly abstract, so the abstract keyword is not needed.
- Methods in an interface are implicitly public.

### 8.Explain the throwing and catching the exception in java.

An exception is a problem that arises during the execution of a program. An exception can occur for many different reasons, including the following:

- A user has entered invalid data.
- A file that needs to be opened cannot be found.
- A network connection has been lost in the middle of communications or the JVM has run out of memory.
- **Checked exceptions:** A checked exception is an exception that is typically a user error or a problem that cannot be foreseen by the programmer. For example, if a file is to be opened, but the file cannot be found, an exception occurs. These exceptions cannot simply be ignored at the time of compilation.
- **Runtime exceptions:** A runtime exception is an exception that occurs that probably could have been avoided by the programmer. As opposed to checked exceptions, runtime exceptions are ignored at the time of compilation.
- **Errors:** These are not exceptions at all, but problems that arise beyond the control of the user or the programmer. Errors are typically ignored in your code because you can rarely do anything about an error. For example, if a stack overflow occurs, an error will arise. They are also ignored at the time of compilation.

### 9.Explain string handling classes in Java with examples.

The java.lang.String class provides a lot of methods to work on string. By the help of these methods, we can perform operations on string such as trimming, concatenating, converting, comparing, replacing strings etc.

Java String is a powerful concept because everything is treated as a string if you submit any form in window based, web based or mobile application.

1. String s="Sachin";
2. System.out.println(s.toUpperCase());//SACHIN
3. System.out.println(s.toLowerCase());//sachin
4. System.out.println(s);//Sachin(no change in original)

### **10.Describe about the different input and output streams and their classes.**

A stream is a sequence of data.In Java a stream is composed of bytes. It's called a stream because it's like a stream of water that continues to flow.

In java, 3 streams are created for us automatically. All these streams are attached with console.

**1) System.out:** standard output stream

**2) System.in:** standard input stream

**3) System.err:** standard error stream

## **UNIT –3 JDBC**

### **1.What do you mean by JDBC?**

JDBC(Java Database Connectivity) is a part of JDK which defines an application programming interface for Java for standard SQL access to database from Java programs.

### **2.Define ODBC.**

ODBC(Open Database Connectivity) is a standard for accessing different database systems. These are interfaces for VB, VC++, SQL and ODBC driver pack contains drivers for the Access, Paradox, dBase, Text, Excel.

### **3.What do you mean by Quick Response?**

Quick Response means better service and availability of a wider range of products.



#### **4. How the database connectivity is established in Java?**

Database connectivity is established in Java using following steps,

Step 1: Loading the driver -> this can be done by

```
Class.forName("sun.jdbc.odbc.JdbcOdbcDriver")
```

Step 2: Registering the driver

```
Connection c1=RegisterDriver.getConnection("jdbc:odbc:DSN");
```

Step 3: create or execute the statement

#### **5. Give some examples of online applications.**

- a) Conference Management system
- b) Purchase system
- c) License Lookup
- d) Exam grade lookup

#### **6. What is the need for ServletConfig(Config Object)?**

A ServletConfig object presents servlet configuration information.

GenericServlet used to create Protocol independent servlets, which accepts 2 parameters to favor request and response cycle namely ServletRequest and ServletResponse. And this can be handled using service() method.

HTTPServlet used to create HTTP Servlets, which accepts 2 arguments to favor the request & response cycle namely, HttpServletRequest & HttpServletResponse. And this can be handled by doGet() & doPost() methods.

#### **7. List out the classification of JDBC drivers?**

It has 4 categories

- a) JDBC-ODBC Bridge
- b) Native API Partly Java Driver
- c) JDBC Net Pure Java Driver
- d) Native Protocol Pure Java Driver

### **8.Can the JDBC-ODBC Bridge be used with applets?**

Use of the JDBC-ODBC bridge from an untrusted applet running in a browser, such as Netscape Navigator, isn't allowed. The JDBC-ODBC bridge doesn't allow untrusted code to call it for security reasons. ODBC is native code, so once ODBC is called the Java programming language can't guarantee that a security violation won't occur. On the other hand, Pure Java JDBC drivers work well with applets. They are fully downloadable and do not require any client-side configuration.

### **9.What causes the "No suitable driver" error?**

"No suitable driver" is an error that usually occurs during a call to the DriverManager.getConnection method. The cause can be failing to load the appropriate JDBC drivers before calling the getConnection method, or it can be specifying an invalid JDBC URL--one that isn't recognized by your JDBC driver. Your best bet is to check the documentation for your JDBC driver or contact your JDBC driver vendor if you suspect that the URL you are specifying is not being recognized by your JDBC driver.

### **10.Is the JDBC-ODBC Bridge multi-threaded?**

No. The JDBC-ODBC Bridge does not support concurrent access from different threads. The JDBC-ODBC Bridge uses synchronized methods to serialize all of the calls that it makes to ODBC. Multi-threaded Java programs may use the Bridge, but they won't get the advantages of multi-threading. In addition, deadlocks can occur between locks held in the database and the semaphore used by the Bridge. We are thinking about removing the synchronized methods in the future. They were added originally to make things simple for folks writing Java programs that use a single-threaded ODBC driver.

### **11.How can you create JDBC statements?**

The JDBC API classes are supported by the java package java.sql.Import java.sql.\* statement.JDBC –ODBC bridge is created by the following statements.

```
Class.forName("sun.jdbc.odbc.JdbcOdbcDriver")
```

Connection to the database can be done using DriverManager.

```
DriverManager.getConnection("jdbc:odbc:My_database", " ", " ");
```

### **12.What is the purpose of java.sql package in JDBC?**

The JDBC API is defined in the java.sql package. To use JDBC classes and interfaces the java.sql is imported in the java program.

### **13. What is prepared statement in JDBC?**

The prepared statement in JDBC is a precompiled SQL statement. It is specified using the placeholder?

```
SELECT * from studentstable where name =?
```

There are special type setter methods that assign the values to the placeholders before the SQL statements get executed.

### **14. What do you understand by Callable Statement in JDBC?**

The Callable Statement is used to represent the stored procedures. In this type of statements we can assign the methods for the type of output arguments.

```
SELECT * from studentstable where rollno<25
```

### **15. What is ResultSet?**

The SQL statements that read data from a database query return the data in a result set. The resultset object maintains a cursor that points to the current row in the database.

### **16. What is Connection class in JDBC?**

The connection class in JDBC is used to represent the connectivity with the data sources. The code a call to the DriverManager objects getConnection() method to establish actual database connection.

### **17. Give the syntax for getConnection() method to establish actual database connection.**

```
Static Connection getConnection(String URL);
```

```
Static Connection getConnection(String URL, Properties info);
```

```
Static Connection getConnection(String URL, String user, String password);
```

### **18. What is meant by datagram?**

Datagram is a type of packet that represents an entire communication. Datagram packet is the class, which acts as the data container, and datagram socket is a mechanism used to send or receive datagram packets

### **19. What are the methods of datagram packet?**

Methods:

Send (Datagram packet d) –dispatches the given datagram packet object.

Receive (Datagram packet p) –receives the given datagram packet object.

Close ()–closes the socket connection

## **20. Define protocol.**

Communication between computers in a network or a different network requires certain set of rules called protocol.

## **21.What are the types of protocol?**

Java networking is done using TCP /IP protocol. Some of the different kinds of protocols available are

HTTP (Hyper Text Transfer Protocol enables interaction with the internet), FTP (File Transfer Protocol enables transfer of files between computers), SMTP (Simple Mail Transfer Protocol provides e-mail facility) and NNTP (Network News Transfer Protocol acts as a bulletin board for sharing news)

## **22.Give the three components of collection frameworks.**

Collection frameworks are composed of three components. They are:

Interfaces –abstract data types representing collections

Implementations–these are the actual execution of the interfaces

Algorithms –these are methods that perform computation on objects that implement the interfaces.

## **23.Define socket.**

A socket is a connection between two hosts. It can perform following basic operations:

a.Connect to a remote machine

b.Send data

c.Receive data

d.Close a connection

e.Bind to a port

f.Listen for incomin

g data

#### **24. Define TCP.**

TCP is designed for reliable transmission of data. If data is lost or damaged in transmission, TCP ensures that the data is resent; if packets of data arrive out of order, TCP puts them back in the correct order; if the data is coming too fast for the connection, TCP throttles the speed back so that packets will not be lost.

#### **25. Write about get methods in the DatagramPacket class.**

DatagramPacket has five methods that retrieve different parts of a datagram: the actual data plus several fields from its header. These methods are mostly used for data grams we receive from the network.

```
public InetAddress getAddress()
```

```
public int getPort()
```

```
public byte[] getData()
```

```
public int getLength()
```

```
public int getOffset()
```

#### **26. Write about set methods in the DatagramPacket class.**

- public void setData(byte[] data)

- public void setData(byte[] data, int offset, int length)

- public void setAddress(InetAddress remote)

- public void setPort(int port)

- public void setLength(int length)

## PART - B

### 1.Explain JDBC architecture in detail.

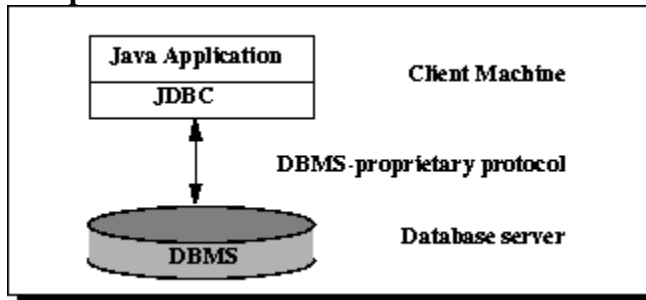

### 2.Discuss about the JDBC driver types.

Type 1: JDBC-ODBC Bridge Driver

Type 2: JDBC-Native API

Type 3: JDBC-Net pure Java

Type 4: 100% Pure Java

### 3.Explain about TCP sockets.

TCP is a twoway communication protocol, so data can be sent across both streams at the same time. There are following usefull classes providing complete set of methods to implement sockets.

#### **ServerSocket Class Methods:**

The **java.net.ServerSocket** class is used by server applications to obtain a port and listen for client requests

The ServerSocket class has four constructors:

#### **public ServerSocket(int port) throws IOException**

1

Attempts to create a server socket bound to the specified port. An exception occurs if the port is already bound by another application.

#### **public ServerSocket(int port, int backlog) throws IOException**

2

Similar to the previous constructor, the backlog parameter specifies how many incoming clients to store in a wait queue.

#### **public ServerSocket(int port, int backlog, InetAddress address) throws IOException**

3

Similar to the previous constructor, the InetAddress parameter specifies the local IP address to bind to. The InetAddress is used for servers that may have multiple IP addresses, allowing the server to specify which of its IP addresses to accept client requests on

#### **public ServerSocket() throws IOException**

4

Creates an unbound server socket. When using this constructor, use the bind() method when you are ready to bind the server socket

If the ServerSocket constructor does not throw an exception, it means that your application has successfully bound to the specified port and is ready for client requests.

### 4. Write notes on UDP sockets.

**DatagramSocket**'s are Java's mechanism for network communication via UDP instead of TCP. UDP is still layered on top of IP. You can use Java's `DatagramSocket` both for sending and receiving UDP datagrams.

### **Sending Data via a DatagramSocket**

To send data via Java's `DatagramSocket` you must first create a `DatagramPacket`. Here is how that is done:

```
byte[] buffer = new byte[65508];
InetAddress address = InetAddress.getByName("jenkov.com");
DatagramPacket packet = new DatagramPacket(
    buffer, buffer.length, address, 9000);
```

The byte buffer (the byte array) is the data that is to be sent in the UDP datagram. The length of the above buffer, 65508 bytes, is the maximum amount of data you can send in a single UDP packet.

The length given to the `DatagramPacket` constructor is the length of the data in the buffer to send. All data in the buffer after that amount of data is ignored.

The `InetAddress` instance contains the address of the node (e.g. server) to send the UDP packet to. The `InetAddress` class represents an IP address (Internet Address). The `getByName()` method returns an `InetAddress` instance with the IP address matching the given host name.

The port parameter is the UDP port the server to receive the data is listening on. UDP and TCP ports are not the same. A computer can have different processes listening on e.g. port 80 in UDP and in TCP at the same time.

To send the `DatagramPacket` you must create a `DatagramSocket` targeted at sending data. Here is how that is done:

```
DatagramSocket datagramSocket = new DatagramSocket();
```

To send data you call the `send()` method, like this:

```
datagramSocket.send(packet);
```

## **5. Write a short notes on JavaBeans classes and JSP**

- JavaBeans Component Design Conventions
- Why Use a JavaBeans Component?
- Creating and Using a JavaBeans Component
- Setting JavaBeans Component Properties

## **6. Discuss the concept of RMI.**

The **RMI** (Remote Method Invocation) is an API that provides a mechanism to create distributed application in java. The RMI allows an object to invoke methods on an object running in another JVM.

The RMI provides remote communication between the applications using two objects *stub* and *skeleton*.

### **Steps to write the RMI program**

1. Create the remote interface
2. Provide the implementation of the remote interface

3. Compile the implementation class and create the stub and skeleton objects using the rmic tool
4. Start the registry service by rmiregistry tool
5. Create and start the remote application
6. Create and start the client application

### 7. Explain jdbc-odbc data base connectivity program.

```

Class.forName("sun.jdbc.odbc.JdbcOdbcDriver");
System.out.println("Driver loaded");

connection = DriverManager.getConnection("jdbc:odbc:Lab3.accdb");
System.out.println("Database connected");

statement = connection.createStatement();
ResultSet resultSet = statement.executeQuery("");

while (resultSet.next()) {
    output.write("<p>" + resultSet.getString(1) + "\t" +
        resultSet.getString(2) + "\t" + resultSet.getString(3) +
"</p>");
}

```

## UNIT 4 APPLETS

### 1. What is a Servlet?

Servlets are modules of Java code that run in a server application (hence the name "Servlets", similar to "Applets" on the client side) to answer client requests. Servlets are not tied to a specific client-server protocol but they are most commonly used with HTTP and the word "Servlet" is often used in the meaning of "HTTP Servlet".

### 2. Compare Servlet with CGI

Servlets have several advantages over CGI:

A Servlet does not run in a separate process. This removes the overhead of creating a new process for each request.

A Servlet stays in memory between requests. A CGI program (and probably also an extensive runtime system or interpreter) needs to be loaded and started for each CGI request.

There is only a single instance which answers all requests concurrently. This saves memory and allows a Servlet to easily manage persistent data.

### 3. What are Applets?

A program designed to be executed from within another application. Unlike an application, applets cannot be executed directly from the operating system. With the growing popularity of OLE (object linking and embedding), applets are becoming more prevalent. A well-designed applet can be invoked from many different applications.

Web browsers, who are often equipped with Java virtual machines, can interpret applets from Web servers. Because applets are small in files size, cross-platform compatible, and highly secure (can't be used to access users' hard drives), they are ideal for small Internet applications accessible from a browser.



#### **4. What are the common mechanisms used for session tracking?**

- Cookies
- SSLsessions
- URL- rewriting

#### **5. What is preinitialization of a servlet?**

A container doesnot initialize the servlets ass soon as it starts up, it initializes a servlet when it receives a request for that servlet first time. This is called lazy loading. The servlet specification defines the <load-on-startup> element, which can be specified in the deployment descriptor to make the servlet container load and initialize the servlet as soon as it starts up. The process of loading a servlet before any request comes in is called preloading or preinitializing a servlet.

#### **6. What is the difference between HttpServlet and GenericServlet?**

A GenericServlet has a service() method aimed to handle requests. HttpServlet extends GenericServlet and adds support for doGet(), doPost(), doHead() methods (HTTP 1.0) plus doPut(), doOptions(), doDelete(), doTrace() methods (HTTP 1.1).

Both these classes are abstract.

#### **7. What is the difference between ServletContext and ServletConfig?**

ServletContext: Defines a set of methods that a servlet uses to communicate with its servlet container, for example, to get the MIME type of a file, dispatch requests, or write to a log file.The ServletContext object is contained within the ServletConfig object, which the Web server provides the servlet when the servlet is initialized

ServletConfig: The object created after a servlet is instantiated and its default constructor is read. It is created to pass.

#### **8. Explain ServletContext**

ServletContext interface is a window for a servlet to view it\'s environment. A servlet can use this interface to get information such as initialization parameters for the web applicationor servlet container\'s version. Every web application has one and only one ServletContext and is accessible to all active resource of that application.

#### **9. Explain the directory structure of a web application.**

The directory structure of a web application consists of two parts.

A private directory called WEB-INF

A public resource directory which contains public resource folder.

WEB-INF folder consists of

1. web.xml
2. classes directory
3. lib directory

#### **10. List any two keyboard events?**

- onKeyPress
- onKeyUp
- onKeyDown

**11. List any two mouse events?**

- onMouseUp
- onMouseDown
- onMouseOver
- onClick

**12. What is the relationship between the Canvas class and the Graphics class?**

A Canvas object provides access to a Graphics object via its paint() method.

**13. How would you create a button with rounded edges?**

There's 2 ways. The first thing is to know that a JButton's edges are drawn by a Border. so you can override the Button's paintComponent(Graphics) method and draw a circle or rounded rectangle (whatever), and turn off the border. Or you can create a custom border that draws a circle or rounded rectangle around any component and set the button's border to it.

**14. What is the difference between the 'Font' and 'FontMetrics' class?**

The Font Class is used to render 'glyphs' - the characters you see on the screen. FontMetrics encapsulates information about a specific font on a specific Graphics object. (width of the characters, ascent, descent)

**15. What is the difference between the paint() and repaint() methods?**

The paint() method supports painting via a Graphics object. The repaint() method is used to cause paint() to be invoked by the AWT painting thread.

**16. Which containers use a border Layout as their default layout?**

The window, Frame and Dialog classes use a border layout as their default layout.

**17. What is the difference between applications and applets?**

a) Application must be run on local machine whereas applet needs no explicit installation on local machine.

b) Application must be run explicitly within a java-compatible virtual machine whereas applet loads and runs itself automatically in a java-enabled browser.

c) Application starts execution with its main method whereas applet starts execution with its init method.

d) Application can run with or without graphical user interface whereas applet must run within a graphical user interface.

**18. Difference between Swing and Awt?**

AWT are heavy-weight components. Swings are light-weight components. Hence swing works faster than AWT.

### **19. What is a layout manager and what are different types of layout managers available in java AWT?**

A layout manager is an object that is used to organize components in a container. The different layouts available are FlowLayout, BorderLayout, CardLayout, GridLayout and GridBagLayout.

### **20. How are the elements of different layouts organized?**

*FlowLayout:* The elements of a FlowLayout are organized in a top to bottom, left to right fashion.

*BorderLayout:* The elements of a BorderLayout are organized at the borders (North, South, East and West) and the center of a container.

*CardLayout:* The elements of a CardLayout are stacked, on top of the other, like a deck of cards.

*GridLayout:* The elements of a GridLayout are of equal size and are laid out using the square of a grid.

*GridBagLayout:* The elements of a GridBagLayout are organized according to a grid. However, the elements are of different size and may occupy more than one row or column of the grid. In addition, the rows and columns may have different sizes.

The *default* Layout Manager of Panel and Panel sub classes is FlowLayout.

### **21. What is source and listener?**

*source :* A source is an object that generates an event. This occurs when the internal state of that object changes in some way.

*listener :* A listener is an object that is notified when an event occurs. It has two major requirements. First, it must have been registered with one or more sources to receive notifications about specific types of events. Second, it must implement methods to receive and process these notifications.

### **22. What is an event and what are the models available for event handling?**

An event is an event object that describes a state of change in a source. In other words, event occurs when an action is generated, like pressing button, clicking mouse, selecting a list, etc. There are two types of models for handling events and they are: a) event-inheritance model and b) event-delegation model

### **23. What is the difference between scrollbar and scrollpane?**

A Scrollbar is a Component, but not a Container whereas Scrollpane is a Container and handles its own events and perform its own scrolling.

### **24. What class is the top of the AWT event hierarchy?**

The java.awt.AWTEvent class is the highest-level class in the AWT event-class hierarchy.

### **25. What is meant by controls and what are different types of controls in AWT?**

Controls are components that allow a user to interact with your application and the AWT supports the following types of controls: Labels, Push Buttons, Check Boxes, Choice Lists, Lists, Scrollbars, and Text Components. These controls are subclasses of Component.

## **26. What is the difference between a Choice and a List?**

A Choice is displayed in a compact form that requires you to pull it down to see the list of available choices. Only one item may be selected from a Choice. A List may be displayed in such a way that several List items are visible. A List supports the selection of one or more List items.

## **27. What is the purpose of the enableEvents() method?**

The enableEvents() method is used to enable an event for a particular object. Normally, an event is enabled when a listener is added to an object for a particular event. The enableEvents() method is used by objects that handle events by overriding their eventdispatch methods.

## **28. What is the difference between the File and RandomAccessFile classes?**

The File class encapsulates the files and directories of the local file system. The RandomAccessFile class provides the methods needed to directly access data contained in any part of a file.

## **29. What is the lifecycle of an applet?**

init() method - Can be called when an applet is first loaded  
start() method - Can be called each time an applet is started.  
paint() method - Can be called when the applet is minimized or maximized.  
stop() method - Can be used when the browser moves off the applet's page.  
destroy() method - Can be called when the browser is finished with the applet.

## **PART – B**

### **1. Explain the life cycle of applet.**

**public void init():** is used to initialize the Applet. It is invoked only once.

**public void start():** is invoked after the init() method or browser is maximized. It is used to start the Applet.

**public void stop():** is used to stop the Applet. It is invoked when Applet is stop or browser is minimized.

**public void destroy():** is used to destroy the Applet. It is invoked only once.

## 2. List the methods available in the graphics for COLOR.

**Graphics() ()** Constructs a new Graphics object.

**abstract void clearRect(int x, int y, int width, int height)**

Clears the specified rectangle by filling it with the background color of the current drawing surface.

**abstract void clipRect(int x, int y, int width, int height)**

Intersects the current clip with the specified rectangle.

**abstract void copyArea(int x, int y, int width, int height, int dx, int dy)**

Copies an area of the component by a distance specified by dx and dy.

**void drawPolygon(Polygon p)**

Draws the outline of a polygon defined by the specified Polygon object.

**abstract void drawString(String str, int x, int y)**

Draws the text given by the specified string, using this graphics context's current font and color.

## 3. How frames are created in Java?

1. Create the frame.

```
JFrame frame = new JFrame("FrameDemo");
```

2. Optional: What happens when the frame closes?

```
frame.setDefaultCloseOperation(JFrame.EXIT_ON_CLOSE);
```

3. Create components and put them in the frame.

```
//...create emptyLabel...
```

```
frame.getContentPane().add(emptyLabel, BorderLayout.CENTER);
```

4. Size the frame.

```
frame.pack();
```

5. Show it.

```
frame.setVisible(true);
```

#### 4.Explain the various event handling in detail.

Event Handling is the mechanism that controls the event and decides what should happen if an event occurs.

**Foreground Events** - Those events which require the direct interaction of user.

**Background Events** - Those events that require the interaction of end user are known as background events.

- **Source** - The source is an object on which event occurs. Source is responsible for providing information of the occurred event to it's handler. Java provide as with classes for source object.
- **Listener** - It is also known as event handler.Listener is responsible for generating response to an event. From java implementation point of view the listener is also an object. Listener waits until it receives an event. Once the event is received , the listener process the event an then returns.

#### 5.Discuss mouse listener and mouse motion listener. Give an example.

MouseListener will enable you to perform actions when the mouse moves over a hotspot. You can also use this to drag things,that will require MouseListener and MouseMotionListener at the same time.

This applet will show a rectangle that will change color when the mouse moves over it.

```
import java.awt.*;
```

```
import java.applet.*;
```

```
import java.awt.event.*;
```

```
public class MouseMotionExample extends Applet implements MouseMotionListener  
{
```

```
    int xpos;
```

```
    int ypos;
```

```
    int rect1xco,rect1yco,rect1width,rect1height;
```

```
    boolean rect1Active;
```

```
    public void init()  
{
```

```
    {
```

```
        rect1xco = 20;
```

```
        rect1yco = 20;
```

```

    rect1width =100;
    rect1height= 50;

    addMouseMotionListener(this);
}

public void paint(Graphics g)
{
if (rect1Active)g.setColor(Color.green);
    else g.setColor(Color.red);

    g.fillRect(rect1xco,rect1yco,rect1width,rect1height);

    g.setColor(Color.blue);

g.drawString("(" +xpos+", "+ypos+")",xpos,ypos);

}

public void mouseMoved(MouseEvent me)
{
    xpos = me.getX();
    ypos = me.getY();
    if (xpos > rect1xco&& xpos < rect1xco+rect1width && ypos > rect1yco
&& ypos < rect1yco+rect1height)
        rect1Active = true;
    else
        rect1Active = false;
    repaint();
}

public void mouseDragged(MouseEvent me)
{
}

```

### **6.Discuss the various types of layout supported by java.**

The BorderLayout arranges the components to fit in the five regions: east, west, north, south and center.

The CardLayout object treats each component in the container as a card. Only one card is visible at a time.

The FlowLayout is the default layout.It layouts the components in a directional flow.

The GridLayout manages the components in form of a rectangular grid.

### **7.Explain Servlet life cycle in detail.**

Methods:

- Init()
- Service()
- Destroy()

### **8.Discuss the Servlets and concurrency concept.**

- Concurrency in web servers.
- Threads.
- Threading issues.
- Thread synchronization.
- Servlet Synchronization.

### **9.Explain about sessions in detail.**

- Creating a session.
- Storing and retrieving attributes.
- Session termination

### **10.Discuss the parameter data concept.**

- Parameter data and query strings.
- Servlets and parameter data.
- Forms and parameter data.

## **UNIT-5 XML AND WEB SERVICES**

### **1.How to represent the XML Document?**

In any markup language, the first element to appear is called the "root element", which defines what kind of document the file will be. In an HTML file, the <html> tag is the root element. An HTML file will always have the HTML element as the root element, while in an XML file, it can be anything.

**Eg:**

```
<phonebook>
<number>
</number>
<name>
</name>
</phonebook>
```

### **2.what is PCDATA in XML**

Parsed Character Data (PCDATA) is a term used about text data that will be parsed by the XML parser. XML parsers normally parse all the text in an XML document. When an XML element is parsed, the text between the XML tags is also parsed:

```
<message>This text is also parsed</message>
```

### **3. Mention any 3 XML Parsers**

- SAX (Simple API for XML) Parser



- DOM (**Document Object Model**) Parser and
- XSLT (**XML Style Sheet**) Parsers.

#### **4. What is the purpose of the XML DTD**

The purpose of a DTD is to define the structure of an XML document. It defines the structure with a list of legal elements:

```
<!DOCTYPE note [ <!ELEMENT note (to,from,heading,body)> <!ELEMENT to (#PCDATA)>
<!ELEMENT from (#PCDATA)> <!ELEMENT heading (#PCDATA)> <!ELEMENT body
(PCDATA)> ]>
```

#### **5. What is XSL Programming?**

XSL (XML Stylesheet) Programming is the Next Generation of the CSS (Cascading Style Sheet Programming). In CSS, users can use certain style tags which the browsers can understand and are predefined by W3 consortium. XSL takes this to one step ahead and users can define any tags in the XML file. XML sheets can help in showing the same data in different formats.

```
<?xml-stylesheet href="doc.xml" type="text/xsl"?>
```

#### **6. What is XSLT?**

XSLT stands for XSL Transformations

XSLT is the most important part of XSL

XSLT transforms an XML document into another XML document

XSLT uses XPath to navigate in XML documents

XSLT is a W3C Recommendation

#### **7. What is Java Server Pages Technology?**

- JSP is a technology, specified and introduced by Sun Microsystems.
- Create dynamic web content (HTML, XML, ...) for a Web Application.
- Make it easier/cleaner to mix static HTML parts with dynamic Java servlet code.
- JSP could make external calls to other Web components as Java Beans, Java Servlet, applets or to forward execution to another JSP document.
- Write Once, Run Anywhere

#### **8. What are Java Servlets?**

Servlets are Java technology's answer to CGI programming. They are programs that run on a Web server and build Web pages.

#### **9. What Is The Use Of XML?**

Extensible Markup Language, derived from SGML (Standard Generalized Markup Language). XML is widely supported open technology (i.e. non-proprietary) for electronic data exchange and storage.

XML is actually a language used to create other markup languages to describe data in a structured manner.

XML documents contain only data, not formatting instructions, so applications that process XML documents must decide how to manipulate or display the document's data.

#### **10. What Do You Mean By DTD in XML?**

- DTD means Document Type Definition.
- DTD file is similar to CSS file, because DTD also contains only styles.
- DTD contains various styles which are to be applied in XML document .
- Like .CSS file .DTD file also should be linked with XML program.

Styles in XML program should be save with .xsl (Xml Style Sheet Language) extension.

#### **11. Define XML.**

XML is a meta-markup language that provides a format for describing structured data. This facilitates more structured declarations of content and more meaningful search results across multiple platforms.

#### **12. Define DTD.**

A DTD is a set of rules that specifies how to use XML markup. It contains specifications for each element, including what the element's attributes are, what values the attributes can take on and what elements can be contained in others.

#### **13. What are the different XSLT elements?**

- Stylesheet
- Value-of
- For-each
- Sort
- Text

#### **14. What is VoiceXML?**

VoiceXML is an emerging standard for speech-enabled applications. Its XML syntax defines elements to control a sequence of interaction dialogs between a user and an implementation platform. VoiceXML uses XML text to drive voice dialogs.

#### **15. What is XQuery?**

XQuery is a W3C initiative to define a standard set of constructs for querying and searching XML documents. XQuery brings database query processing to XML.

#### **16. What is XForm?**

XForm is an XML approach that overcomes the limitations of HTML forms. XForm includes a variety of buttons, scrollbars and menus. It generates XML form data as output. XForm's model has the capability to work with the variety of user interfaces.

#### **17. What is XPath?**

Xpath is used to navigate XML tree structures. XPath gets its name from its use of a path notation to navigate through the hierarchical tree structure of an XML document. It is an important XML technology due to its role in providing a common syntax and semantics for functionality in both XSLT and XPointer.

### **18. what are the Important of SAX?**

SAX is an event driven.

SAX supports processing pipelines.

SAX requires programmers to maintain state.

### **19. What is the use of web services?**

- Web services encompass a set of related standards that can enable two computer
- The data is passed back and forth using standard protocols such as HTTP, the same protocol used to transfer ordinary web pages.
- Web services operate using open, text-based standards that enable components written in different languages and on different platforms to communicate.
- They are ready to use pieces of software on the Internet. XML, SOAP, Web Services Description Language (WSDL) and Universal Description, Discovery and Integration (UDDI) are the standards on which web services rely.
- UDDI is another XML based format that enables developers and business to publish and locate Web services on a network.

### **20. What do you mean by JDBC?**

- JDBC Part of the Java Development Kit which defines an application-programming interface for Java for standard SQL access to databases from Java programs.

### **21. Define ODBC.**

- It is a standard for accessing different database systems. There are interfaces for Visual Basic, Visual C++, SQL and the ODBC driver pack contains drivers for the Access, Paradox, dBase, Text, Excel and Retrieve databases.

### **22. List out some web service technologies?**

XML,

SOAP,

WSDL

### **23. What is XML ?**

**Extensible markup language.** It offer a standard, flexible and inherently extensible data format, XML significantly reduces the burden of deploying the many technologies needed to ensure the success of Web services.

## **24. What is SOAP?**

### **Service Oriented Architecture Protocol.**

It provides a standard, extensible, composable framework for packaging and exchanging XML messages. In the context of this architecture, SOAP also provides a convenient mechanism for referencing capabilities (typically by use of headers).

## **25. What is WSDL?**

### **Web Services Description Language**

WSDL is a language for describing Web services. WSDL describes Web services starting with the messages that are exchanged between the requester and provider agents. The messages themselves are described abstractly and then bound to a concrete network protocol and message format.

## **26. What are Web Services?**

Web services are application components

Web services communicate using open protocols

Web services are self-contained and self-describing

Web services can be discovered using UDDI

Web services can be used by other applications

XML is the basis for Web services

## **27. How Does web services Work?**

The basic Web services platform is XML + HTTP.

XML provides a language which can be used between different platforms and programming languages and still express complex messages and functions.

The HTTP protocol is the most used Internet protocol.

## **28. What are the various web services platform elements?**

- SOAP (Simple Object Access Protocol)
- UDDI (Universal Description, Discovery and Integration)
- WSDL (Web Services Description Language)

## **29. What are the types of web services and its uses?**

### **Reusable application-components.**

There are things applications need very often. So why make these over and over again?

Web services can offer application-components like: currency conversion, weather reports, or even language translation as services.

### **Connect existing software.**

Web services can help to solve the interoperability problem by giving different applications a way to link their data. With Web services you can exchange data between different applications and different platforms.

## **30. Define WSDL.**

WSDL 2.0[WSDL 2.0 Part 1] is a language for describing Web services.

WSDL describes Web services starting with the messages that are exchanged between the requester and provider agents. The messages themselves are described abstractly and then bound to a concrete network protocol and message format.

## **31. Write short notes on UDDI**

Universal Description, Discovery, and Integration (UDDI) The directory shown in the above figure could be a UDDI registry. The UDDI registry is intended to eventually serve as a means of "discovering" Web Services described using WSDL . The idea is that the UDDI registry can be searched in various ways to obtain contact information and the Web

Services available for various organizations. How much "discovery" will be used in the early days of Web Services is open to discussion. Nevertheless, even without the discovery portion, the UDDI registry is a way to keep up-to-date on the Web Services your organization currently uses. More on Universal Description, Discovery, and Integration (new window).

An alternative to UDDI is the ebXML Registry (new window).

### 32. What are modeling DTD?

- Data models can be mapped to many different DTDs
- What is a good DTD? What is a bad DTD?
- How does the DTD affect further processing

### 33. What are the soap related technologies?

- SOAP is a simple XML-based protocol to let applications exchange information over HTTP.
- In our SOAP tutorial, you will learn what SOAP is, and how it uses XML to exchange information between applications.

### 34. Define SOAP structure

**SOAP** once stood for 'Simple Object Access Protocol' but this acronym was dropped with Version 1.2 of the standard.

Version 1.2 became a W3C recommendation on June 24, 2003. The acronym is sometimes confused with **SOA**, which stands for Service-oriented architecture; however SOAP is different from SOA.

### 35. What Are Environment Variables?

Environment Variables are stored in a small area of memory available to all programs running within or on top of the DOS environment (including Windows). They are called —variables because they can be changed. In fact, some variables need to be re established after every reboot.

#### 1. Explain the java web service in detail.

- Currency conversion service.
- Writing server software.
- Packaging server software.

#### 2. Explain in detail about XML Schema.

- Built in data types.
- User defined simple types.
- User defined complex types.
- Xml schema with in instance documents.

#### 3. Explain WSDL in detail.

- WSDL stands for Web Services Description Language
- WSDL is written in XML
- WSDL is an XML document
- WSDL is used to describe Web services
- WSDL is also used to locate Web services

- WSDL is a W3C recommendation

#### 4. Explain Soap Concepts.

- SOAP elements.
- RPC representation.
- SOAP encoding of data.
- SOAP encoding of arrays.
- SOAP and HTTP.
- Java support for SOAP.

#### 5. Explain Web Services Architecture.

