

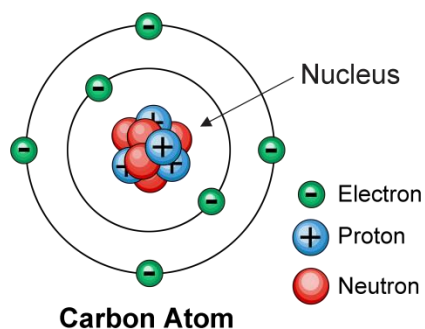

## THE ATOMIC ABSORPTION SPECTROSCOPY

AAS is an analytical technique used to determine the concentration of metal atoms/ions in a sample. Metals make up around 75% of the earth's chemical elements. The science of atomic spectroscopy has yielded three techniques for analytical use: atomic emission, atomic absorption, and atomic fluorescence.

The atom is made up of a nucleus surrounded by electrons. Every element has a specific number of electrons which are associated with the atomic nucleus in an orbital structure which is unique to each element. The electrons occupy orbital positions in an orderly and predictable way. The lowest energy, most stable electronic configuration of an atom, known as the "ground state", is the normal orbital configuration for an atom.



Protons-6, Neutrons -6, Electrons- 6(2+4) , Atomic Number -6, Mass Number -12

If energy of the right magnitude is applied to an atom, the energy will be absorbed by the atom, and an outer electron will be promoted to a less stable configuration or "excited state". As this state is unstable, the atom will immediately and spontaneously return to its ground state configuration. The electron will return to its initial, stable orbital position, and radiant energy equivalent to the amount of energy initially absorbed in the excitation process will be emitted.

The process is illustrated in Figure 1-1. Note that in Step 1 of the process, the excitation is forced by supplying energy. The decay process in Step 2, involving the emission of light, occurs spontaneously.

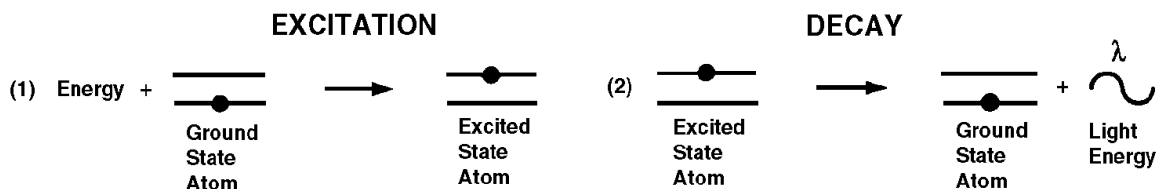



## PRINCIPLE

- If light of just the right wavelength impinges on a free, ground state atom, the atom may absorb the light as it enters an excited state in a process known as atomic absorption.
- All atoms or ions can absorb light at specific, unique wavelengths. When a sample containing copper (Cu) and nickel (Ni), for example, is exposed to light at the characteristic wavelength of Cu, then only the Cu atoms or ions will absorb this light. The amount of light absorbed at this wavelength is directly proportional to the concentration of the absorbing ions or atoms. The absorbance is given by Beer Lambert's law; the logarithmic ratio of the intensity of incident light to the intensity of absorbing species.

$$A = \log \frac{I_0}{I_t} = KLN_o$$

Where,

$N_o$  = concentration of atoms in the flame

L = path length through the flame

K = constant related to absorption coefficient

For example, If a solution containing metal salt ( $M+X^-$ ) is aspirated to the flame, a vapor that contains atoms of metal may be formed. A large number of the gaseous metal atom remains in the ground state, and are capable of absorbing radiant energy of their specific wavelength. If the light of resonance wavelength is passed through the flame containing the atoms which are analyte, the part of the light will be absorbed and the extent of absorption will be directly proportional to the concentration of metal atoms present in the flame. The process by which gaseous metal atoms are produced into the flame can be illustrated as steps,

1. The sample is aspirated to flame, the solvent is vaporized leaving the particles of solid salt.
2. The solid salt on further heating gets burned and converts into gas form, which is dissociated into free neutral atoms.
3. Some of them are excited by the flame heat.



4. Remaining atoms in the ground state absorbs the light of specific wavelength emitted by the lamp of the same element and the intensity of the light absorbed will be determined.
5. it is possible only if the course of radiation is made of the same element which is going to be analyzed.
6. i.e, if the sample is  $\text{Na}^+$  metal ions, then the source of radiation should be made of Sodium metal.

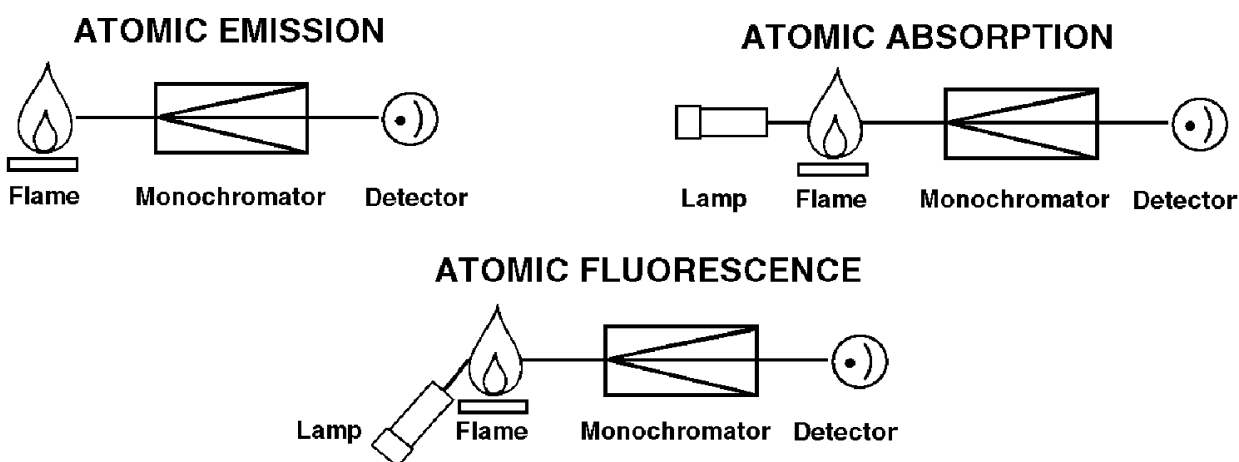

### INSTRUMENTATION

To understand the workings of the atomic absorption spectrometer, let us build one, piece by piece. Every absorption spectrometer must have components which fulfill the three basic requirements shown in Figure 2-1. There must be:

1. A light source;
2. a chopper
3. Sample cell
4. An Atomizer
5. Monochromator
6. Detector
7. Readout Device.

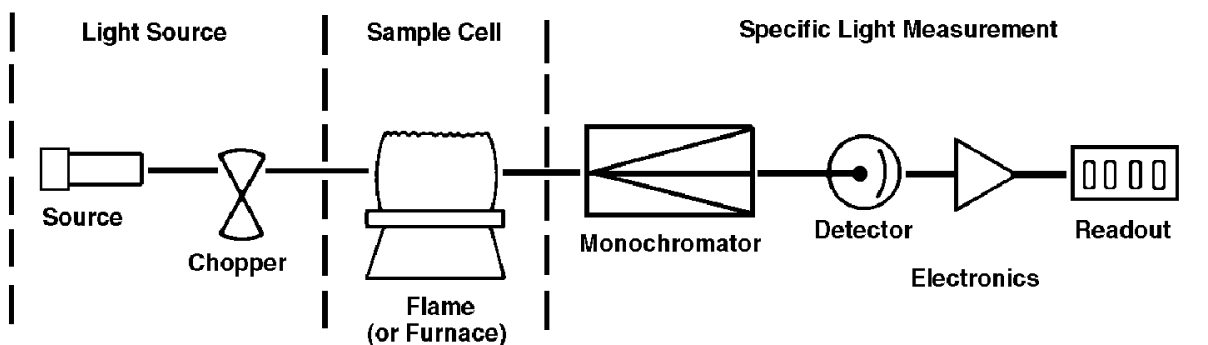

Figure 2-1. Requirements for a spectrometer.

## I, LIGHT SOURCES

An atom absorbs light at discrete wavelengths. In order to measure this narrow light absorption with maximum sensitivity, it is necessary to use a line source, which emits the specific wavelengths which can be absorbed by the atom. Narrow line sources not only provide high sensitivity, but also make atomic absorption a very specific analytical technique with few spectral interferences. The two most common line sources used in atomic absorption are the “hollow cathode lamp” and the “electrodeless discharge lamp.”

### 1. The Hollow Cathode Lamp

The hollow cathode lamp is an excellent, bright line source for most of the elements determinable by atomic absorption.

#### CONSTRUCTION

- Hollow cathode lamp consists of a cathode and an anode
- The cathode of the lamp frequently is a hollowed-out cylinder of the metal whose spectrum is to be produced.
- The anode and cathode are sealed in a glass cylinder normally filled with either neon or argon at low pressure.
- At the end of the glass cylinder is a window transparent to the emitted radiation.

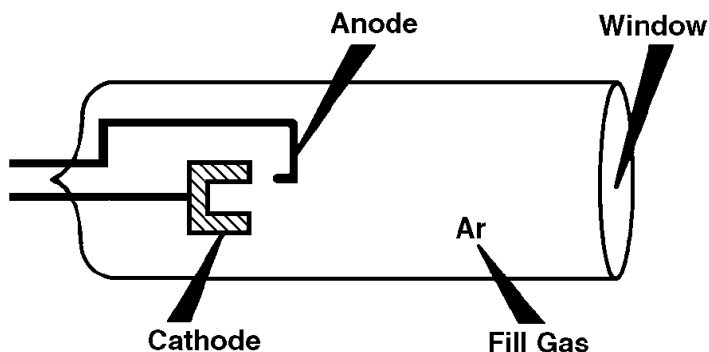

### WORKING

- When an electrical potential is applied between the anode and cathode, some of the fill gas atoms are ionized.
- The positively charged fill gas ions ( $\text{Ar}^+$ ) accelerate through the electrical field to collide with the negatively charged cathode and dislodge individual metal atoms ( $\text{M}^0$ ) in a process called “sputtering”.
- Sputtered metal atoms are then excited to an emission state ( $\text{M}^*$ ) through a kinetic energy transfer by impact with fill gas ions.

#### 1. SPUTTERING

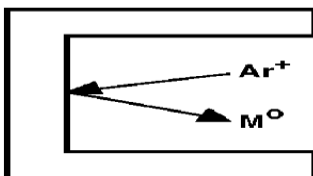

#### 2. EXCITATION

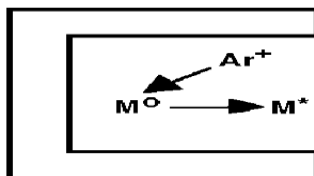

#### 3. EMISSION

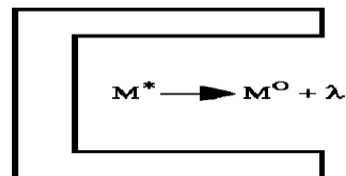

## 2. The Electrodeless Discharge Lamp

In some cases, when the sample is more volatile elements hollow cathode tube is a problem. The atomic absorption determination of these elements can often be dramatically improved with the use of brighter, more stable sources such as the “electrodeless discharge lamp”.



## CONSTRUCTION

- A small amount of the metal or salt of the element for which the source is to be used is sealed inside a quartz bulb.
- This bulb is placed inside a small, self-contained RF generator or “driver”.  
Radiofrequency (rf) energy is used to form a plasma in the gas.

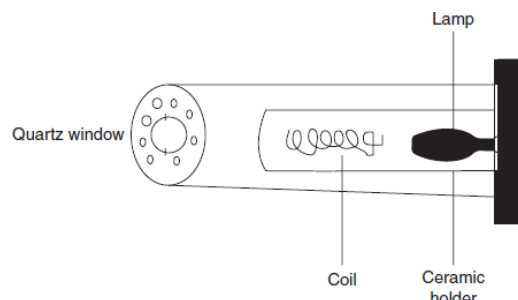

## WORKING

- When power is applied to the driver, an RF field is created.
- The coupled energy will vaporize and excite the atoms inside the bulb, causing them to emit their characteristic spectrum.
- An accessory power supply is required to operate an EDL.

## ADVANTAGES

- Electrodeless discharge lamps are typically much more intense and, in some cases, more sensitive than comparable hollow cathode lamps.
- They therefore offer the analytical advantages of better precision and lower detection limits where an analysis is intensity limited. In addition to providing superior performance, the useful lifetime of an EDL is typically much greater than that of a hollow cathode lamp for the same element.

## II, A CHOPPER.

A rotating wheel is interposed between the hollow cathode and the lamp. This is called a chopper and is interposed to break the steady light from the lamp into an intermittent or pulsating light.

There will be a steady current produced by lamp source. but only the pulsating current is amplified and recorded .



### **III, SAMPLE CELL**

Special considerations are also required for a sample cell for atomic absorption. An atomic vapor must be generated in the light beam from the source. This is generally accomplished by introducing the sample into a burner system or electrically heated furnace aligned in the optical path of the spectrophotometer.

### **IV, ATOMISER.**

Atomizer In order for the sample to be analyzed, it must first be atomized. This is an extremely important step in AAS because it determines the sensitivity of the reading. The most effective atomizers create a large number of homogenous free atoms.

There are many types of atomizers, but only two are commonly used:

- Flame atomizers and
- Electrothermal atomizers

#### **1. Flame atomizer**

Flame atomizers are widely used for a multitude of reasons including their simplicity, low cost, and long length of time that they have been utilized.

It accept an aerosol from a nebulizer into a flame that has enough energy to both volatilize and atomize the sample. When this happens, the sample is dried, vaporized, atomized, and ionized.. The flame itself should meet several requirements including sufficient energy, a long length, non-turbulent, and safe.

***It is of 2 types, Total consumption burner And Premixed burner.***

Total consumption burner - It consist of the oxidizer inlet , sample inlet and fuel inlet. Due to the high pressure of fuel and oxidant the sample solution is aspirate through capillary and burnt at the tip of burner

- Hydrogen and oxygen are generally employed as fuel and oxidant.
- The advantage over other is the entire consumption of sample,
- It's disadvantage is the production of non uniform flame and turbulent.

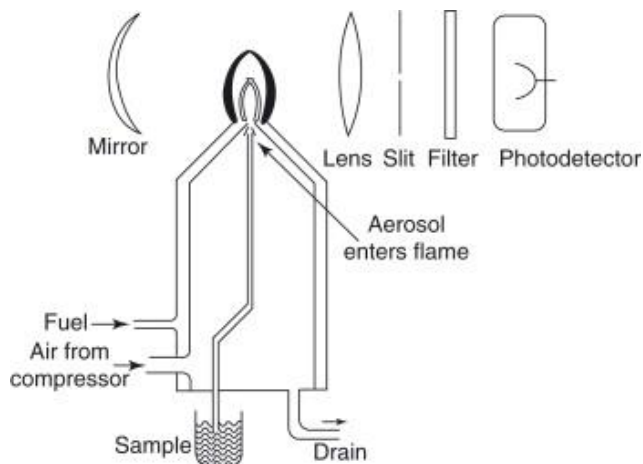

### Premix Burner

- In this burner the sample, fuel oxidant are thoroughly mixed before aspiration and reaching to flame. Premix burner system really consists of two key components, the burner head or nozzle, and the gas-air mixing device that feeds it.
- The fuel and support gases are mixed in a chamber before they enter the burner head (through a slot) where they combust.
- The sample solution is again aspirated through a capillary by the 'Venturi effect' using the support gas for the aspiration.
- Large droplets of the sample condense and drain out of the chamber. The remaining fine droplets mix with the gases and enter the flame.
- As much as 90% of the droplets condense out, leaving only 10% to enter the flame.
- The 90% of the sample that does not reach the flame will travel back through the mixing chamber and out as waste drain.

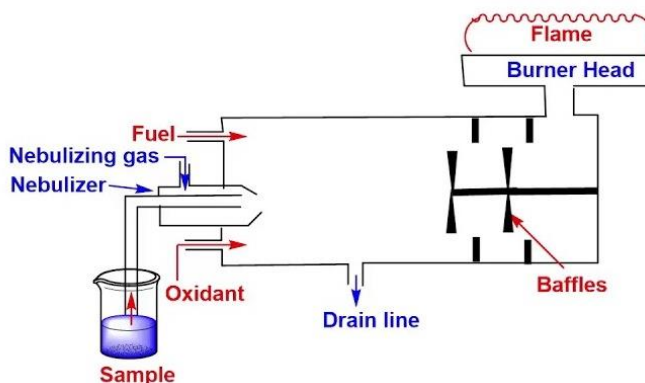





## 2. Electrothermal atomizer

Although electrothermal atomizers were developed before flame atomizers, they did not become popular until more recently due to improvements made to the detection level. They employ graphite tubes that increase temperature in a stepwise manner. Electrothermal atomization first dries the sample and evaporates much of the solvent and impurities, then atomizes the sample, and then rises it to an extremely high temperature to clean the graphite tube.

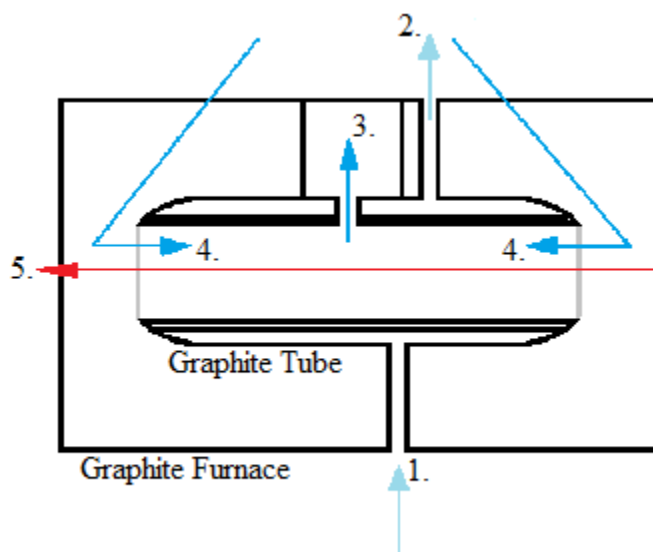

Schematic diagram of an electrothermal atomizer showing the external gas flow inlet (1), the external gas flow outlet (2), the internal gas flow outlet (3), the internal gas flow inlet (4), and the light beam (5).

Some requirements for this form of atomization are the ability to maintain a constant temperature during atomization, have rapid atomization, hold a large volume of solution, and emit minimal radiation. Electrothermal atomization is much less harsh than the method of flame atomization.

## V, MONOCHROMATOR

They are used to separate the different wavelengths of light before they pass to the detector. The monochromator used in AAS can be either single-beam or double-beam. Single-beam only require radiation that passes directly through the atomized sample, while double-beam



spectrometers require two beams of light; one that passes directly through the sample, and one that does not pass through the sample at all. Double-beam monochromators have more optical components, but they are more stable over time because they can compensate for changes more readily

#### VI. DETECTOR

The radiation emitted by the elements is mostly in the visible region. Hence conventional detectors like photo voltaic cell or photo tubes can be used. In a flame spectrophotometer, photomultiplier tube is used as detector. (Refer- UV Detector)

#### VII. READ OUT DEVICE.

In most of the atomic absorption measurements, chart recorders are used as read-out devices. A clean recorder is a potentiometer using a servomotor to move the recording pen. The displacement is directly proportional to the input voltage.

#### Reference

1. A Text book of instrumental methods of Chemical analysis by Gurdeep R Chatwal and Sham K Anand, 5th edition, 2016, pg no-2.340-2.366
2. Concepts, Instrumentation and Techniques in Atomic Absorption Spectrophotometry, Richard D. Beaty and Jack D. Kerber, Second Edition, pg no 1.3 to 2.9