



Unit 4 – Topic 5

Material Handling – Screw Conveyor & Chain conveyor

The screw conveyor consists of a tubular or U-shaped trough in which a shaft with spiral screw revolves. The screw shaft is supported by end and hanger bearing. The rotation of screw pushes the grain along the trough. The screw conveyor is used in grain handling facilities, animal feed industries and other installations for conveying of products generally for short distances. Screw conveyor requires relatively high power and is more susceptible to wear than other types of conveyors. The pitch of a standard screw which is the distance from the centre of one thread to the centre of the next thread, is equal to its diameter.

The screw conveyor's driving mechanism is simpler and no tensioning device is required therefore, the initial cost of the conveyor is lower than any other conveyor with the same length and capacity. The main parts of a screw conveyor are, screw blade, screw shaft, trough, inlet and outlet gates, bearings and drive mechanism.



The screw conveyor is generally used to move grains horizontally. However, it can also be used at any angle upto 90° from the horizontal, but the capacity correspondingly reduced as per the inclination of conveyance.

The screw basically consists of a shaft and the screw blade or flight. The flight is a continuous one piece helix, shaped from a flat strip of steel welded onto the shaft. The screw shaft is usually a jointless tube with thick sides and a high tensile strength to reduce the weight. The thickness of the steel strip helix decreases from the inner edge to the outer edge.



SNS COLLEGE OF TECHNOLOGY
(An Autonomous Institution)
Coimbatore – 641035.

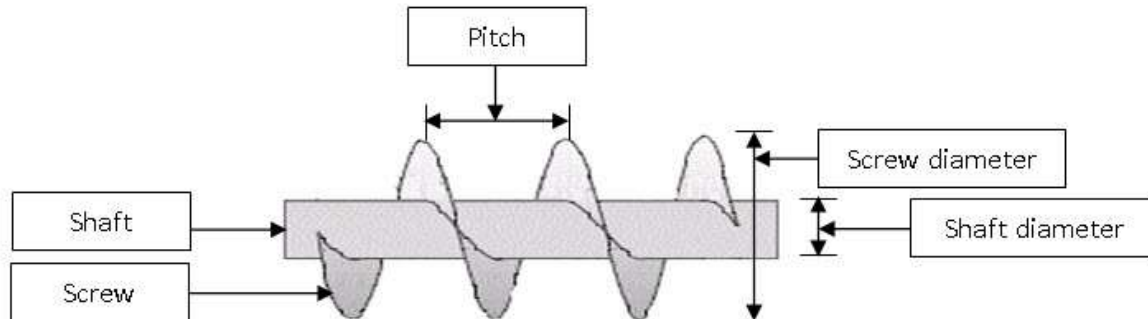

Troughs of screw conveyor have different shapes. Most common is U-shaped trough. In an enlarged or flared trough the side walls become wider at the top. This type of trough is usually used for conveying non-easy flowing materials which may have lumps. The tubular trough is completely closed with circular x-section and mostly used for conveying materials at inclination or for vertical lift.

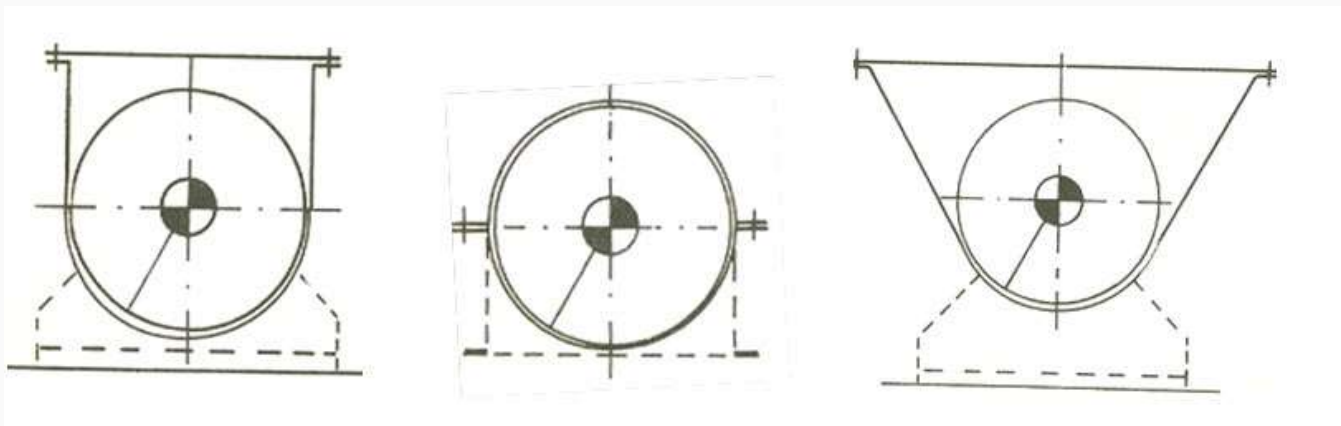

For operational reasons, some gap is provided between the edge of the screw blade and the trough walls. Due to this gap, it is not possible to completely empty the trough of a horizontal screw conveyor. If the screw conveyor is used to convey different materials, mixing of products is possible. Also, when the kernels are pressed between the screw edge and trough walls, they can be damaged. During conveyance, the kernels are also subjected to continuous friction with the trough walls. Screw conveyor may be designed for clockwise or counter-clockwise rotation. The change in direction of rotation does not affect the capacity.

The capacity of screw conveyor is influenced by the screw diameter, inclination of the screw blade, speed of the blade, shaft diameter and cross-section of loading. The theoretical conveyance capacity of the screw conveyor can be calculated by the following equation.

Capacity ,

Where,

D = screw diameter, m



SNS COLLEGE OF TECHNOLOGY
(An Autonomous Institution)
Coimbatore – 641035.



d = shaft diameter, m

p = pitch, m

n = rpm

The power requirement of screw conveyors for horizontal operation may be determined by the following equation.

Where,

Q = conveyor capacity,

L = conveyor length, m

W = bulk material weight,

F = material factor

Screw conveyors can be operated in an inclined position. In this case, the material will be conveyed upward. The capacity of inclined screw conveyor decreases than the horizontal operation. Loading and discharge of a screw conveyor can be take place at several places.

The product supply should be regular to avoid overfilling and congestion in a screw conveyor. To regularize product flow an adjustable opening at the feeding point should be provided. The product can be discharged either at the end of the screw or the intermediate discharge can be achieved through an opening in the bottom of the trough.

Chain conveyor

A chain conveyor is a type of conveyor system that uses a continuous chain to transport materials along a path. This type of conveyor is commonly used in industrial settings for the movement of heavy items or bulk materials. Here are key aspects related to chain conveyors:

1. Chain Types:

- Chain conveyors use a continuous chain, which can be made of various materials, including metal or plastic. The chain is typically driven by a motorized sprocket to move materials along the conveyor.

2. Applications:

- Chain conveyors are well-suited for transporting heavy or bulk materials over long distances. They find applications in industries such as manufacturing, mining, agriculture, and logistics, where the movement of large and heavy items is required.



SNS COLLEGE OF TECHNOLOGY
(An Autonomous Institution)
Coimbatore – 641035.



3. Types of Chain Conveyors:

- There are various types of chain conveyors, including:
 - Drag Chain Conveyors: These conveyors use a single or multiple chains to pull materials along the conveyor path.
 - Apron Conveyors: These have overlapping metal or plastic plates attached to the chain, forming a continuous moving surface.
 - En-Masse Conveyors: Materials are conveyed in a solid, en-masse flow, making them suitable for moving bulk materials.