



SNS COLLEGE OF TECHNOLOGY

(An Autonomous Institution)
COIMBATORE-35

Accredited by NBA-AICTE and Accredited by NAAC – UGC with A+ Grade
Approved by AICTE, New Delhi & Affiliated to Anna University, Chennai



23EET101 / BASICS OF ELECTRICAL AND ELECTRONICS ENGINEERING I YEAR / I SEMESTER

UNIT-I:AC CIRCUITS Topic:KCL

10.9.23

23EET101 / BEEE / S.SHARMILA / AP / EEE



1/13



TOPIC OUTLINE



- ✓ Introduction
- ✓ KCL
- ✓ Problems



10.9.23

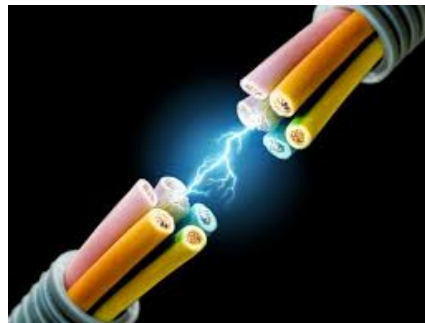

23EET101 / BEEE / S.SHARMILA / AP / EEE



2/13





Introduction

HISTORY OF KIRCHOFF'S LAW

INTRODUCTION

TYPES OF KIRCHOFF'S LAW



HISTORY

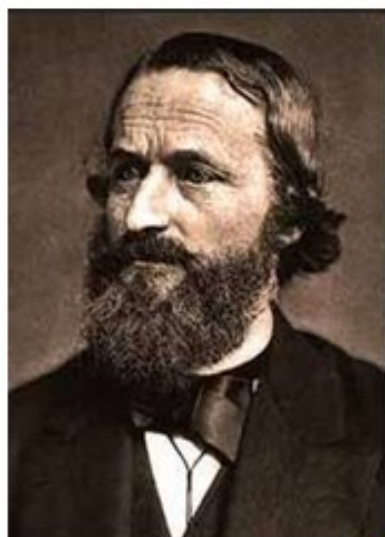

Gustav Robert Kirchhoff
(German physicist)

- described two laws that became central to electrical engineering in 1845
- The laws were generalized from the work of Georg Ohm
- It's can also be derived from Maxwell's equations, but were developed prior to Maxwell's work



LAWS

- A pair of laws stating general restrictions on the current and voltage in an electric circuit
- The first of these states that at any given instant the sum of the voltages around any closed path, or loop, in the network is zero.
- The second states that at any junction of paths, or node, in a network the sum of the currents arriving at any instant is equal to the sum of the currents flowing away.



TYPES

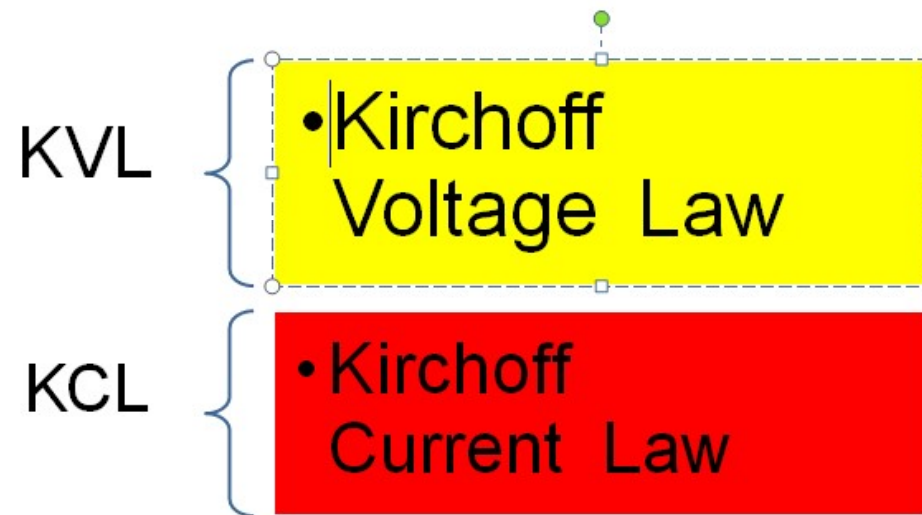



Introduction to KVL

— Kirchhoff's Voltage Law - KVL - is one of two fundamental laws in electrical engineering, the other being Kirchhoff's Current Law (KCL)

— KVL is a fundamental law, as fundamental as Conservation of Energy in mechanics, for example, because KVL is really conservation of electrical energy

— KVL and KCL are the starting point for analysis of any circuit

— KCL and KVL always hold and are usually the most useful piece of information you will have about a circuit after the circuit itself



KVL



- Kirchoff's Voltage Law (KVL) states that the algebraic sum of the voltages across any set of branches in a closed loop is zero. i.e.;

$$\sum V_{\text{across branches}} = 0$$



KVL

- Below is a single loop circuit. The KVL computation is expressed graphically in that voltages around a loop are summed up by traversing (figuratively walking around) the

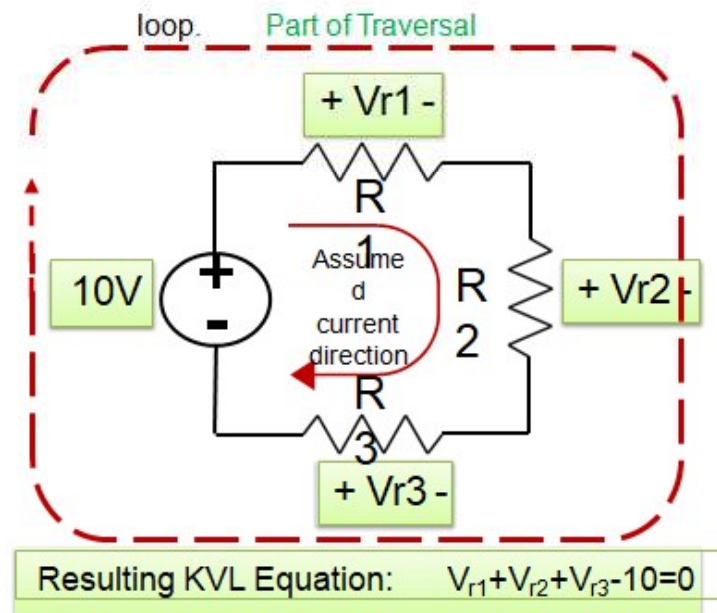

KVL



- The KVL equation is obtained by traversing a circuit loop in either direction and writing down unchanged the voltage of each element whose “+” terminal is entered first and writing down the negative of every element’s voltage where the minus sign is first met.
- The loop must start and end at the same point. It does not matter where you start on the loop.
- Note that a current direction must have been assumed. The assumed current creates a voltage across each resistor and fixes the position of the “+” and “-” signs so that the passive sign convention is obeyed.
- The assumed current direction and polarity of the voltage across each resistor must be in agreement with the passive sign convention for KVL analysis to work.
- The voltages in the loop may be summed in either direction. It makes no difference except to change all the signs in the resulting equation. Mathematically speaking, its as if the KVL equation is multiplied by -1. See the illustration below.

KVL

Summation of voltage terms may be done in either direction

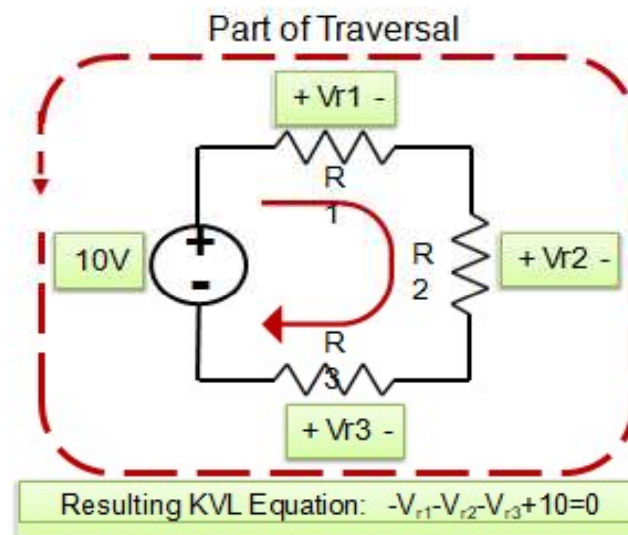
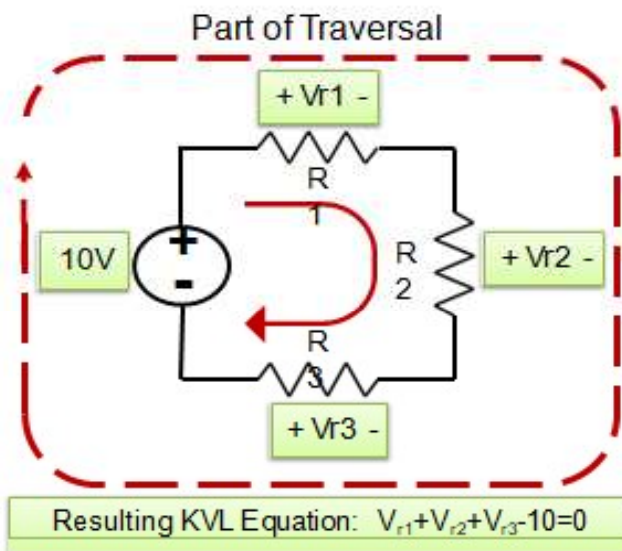

For both summations, the assumed current direction was the same

KVL

Assuming the current direction fixes the voltage references

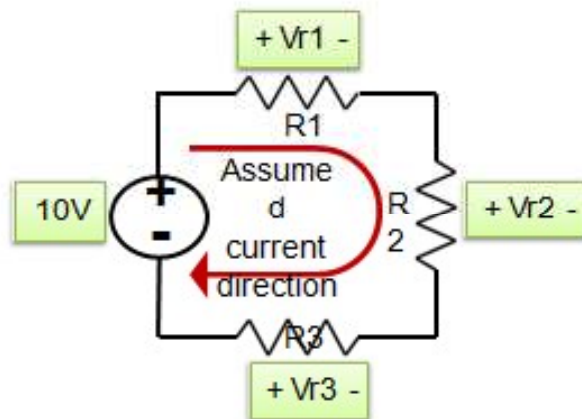

Resulting KVL Equation: $V_{r1} + V_{r2} + V_{r3} - 10 = 0$

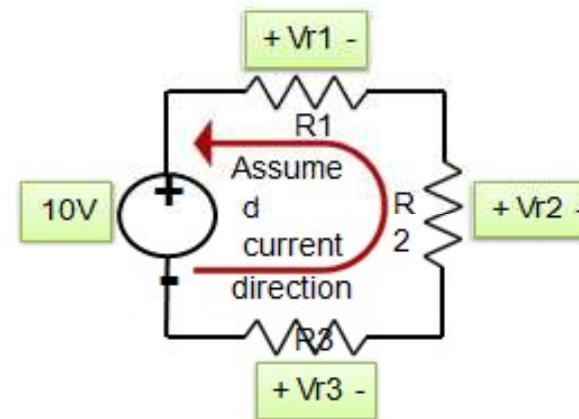

Resulting KVL Equation: $-V_{r1} - V_{r2} - V_{r3} - 10 = 0$

For both cases shown, the direction of summation was the same



RECAP....

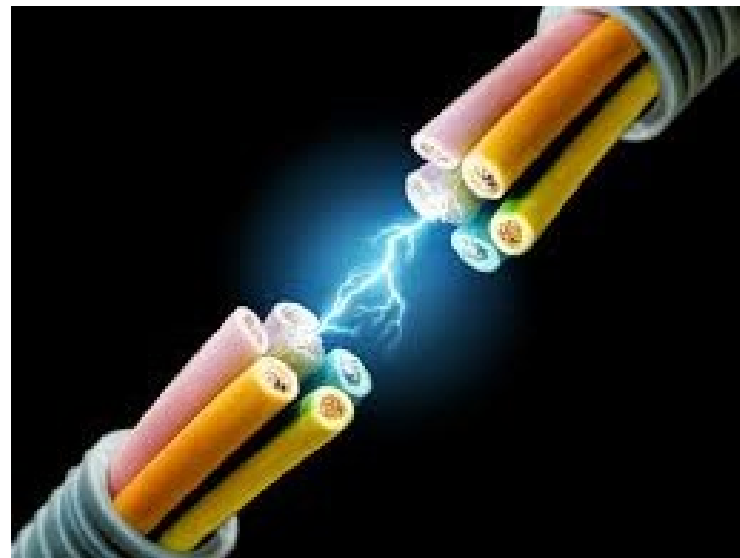

...THANK YOU

