



SNS COLLEGE OF TECHNOLOGY

Coimbatore-35
An Autonomous Institution



Accredited by NBA – AICTE and Accredited by NAAC – UGC with 'A++' Grade
Approved by AICTE, New Delhi & Affiliated to Anna University, Chennai

DEPARTMENT OF ELECTRONICS & COMMUNICATION ENGINEERING

OPTICAL AND MICROWAVE ENGINEERING

III YEAR/ VI SEMESTER

1

UNIT 1 – MICROWAVE PASSIVE DEVICES

TOPIC – Wave guide Corners,Bends,Twists



Wave guide Corners,Bends,Twists

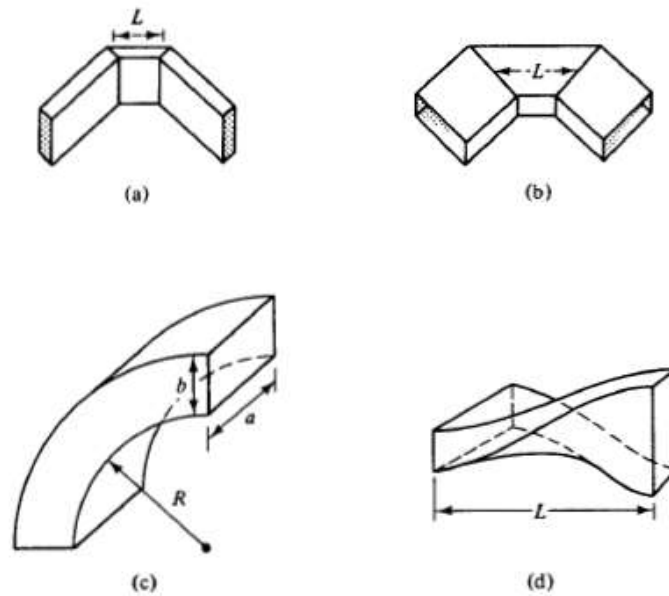

Waveguide corner, bend, and twist. (a) E-plane corner. (b) H-plane corner. (c) Bend. (d) Continuous twist



Wave guide Tee

A Waveguide Tee is a 3-port device that can be used to either divide or combine power in a waveguide system. It is formed when three waveguide tubes are connected in the form of the English alphabet 'T'. This is where its name is derived from.





Waveguide twists



Waveguide twists

There are also instances where the waveguide may require twisting. This too, can be accomplished. A gradual twist in the waveguide is used to turn the polarization of the waveguide and hence the waveform.

In order to prevent undue distortion on the waveform a 90° twist should be undertaken over a distance greater than two wavelengths of the frequency in use. If a complete inversion is required, e.g. for phasing requirements, the overall inversion or 180° twist should be undertaken over a four wavelength distance.

Waveguide bends and waveguide twists are very useful items to have when building a waveguide system. Using waveguide E bends and waveguide H bends and their strap bend counterparts allows the waveguide to be turned through the required angle to meet the mechanical constraints of the overall waveguide system. Waveguide twists are also useful in many applications to ensure the polarization is correct.



THANK YOU