



SNS COLLEGE OF TECHNOLOGY

(An Autonomous Institution)

COIMBATORE-35

Accredited by NBA-AICTE and Accredited by NAAC – UGC with A+ Grade
Approved by AICTE, New Delhi & Affiliated to Anna University, Chennai



19EET101 / BASICS OF ELECTRICAL AND ELECTRONICS ENGINEERING

I YEAR / I SEMESTER

UNIT-I: ELECTRICAL CIRCUITS AND MEASUREMENTS

WATTMETER, ENERGY METER



TOPIC OUTLINE



- Electro dynamic Wattmeter
 - Induction type Energy meter
 - Evaluation





ELECTRO-DYNAMIC WATTMETER

- **Principle** depends upon the electromagnetic force exerted between fixed and moving coils carrying current.
- Two coils - **fixed coil (PC)** and **moving coil (CC)** carried by spindle.
- Controlling torque is provided by two spiral springs mounted on the spindle



ELECTRO-DYNAMIC WATTMETER

Operation:

- The deflecting torque is proportional to the product of the current in the current coil and voltage across pressure coil.
- Deflecting torque is proportional to power.
- The scale of this instrument is uniform.
- It is used for AC and DC power measurement



ELECTRO-DYNAMIC WATTMETER

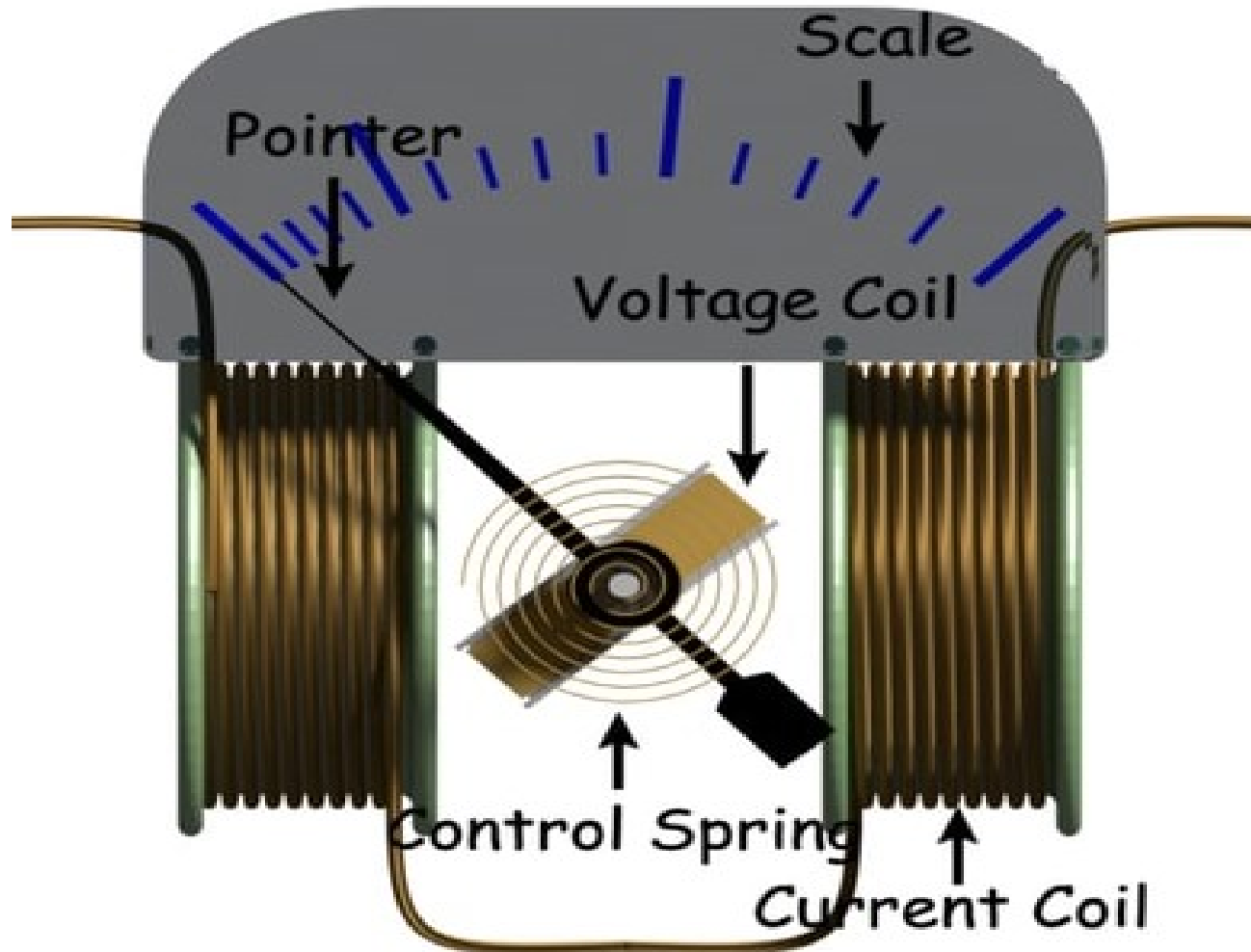



ELECTRO-DYNAMIC WATTMETER

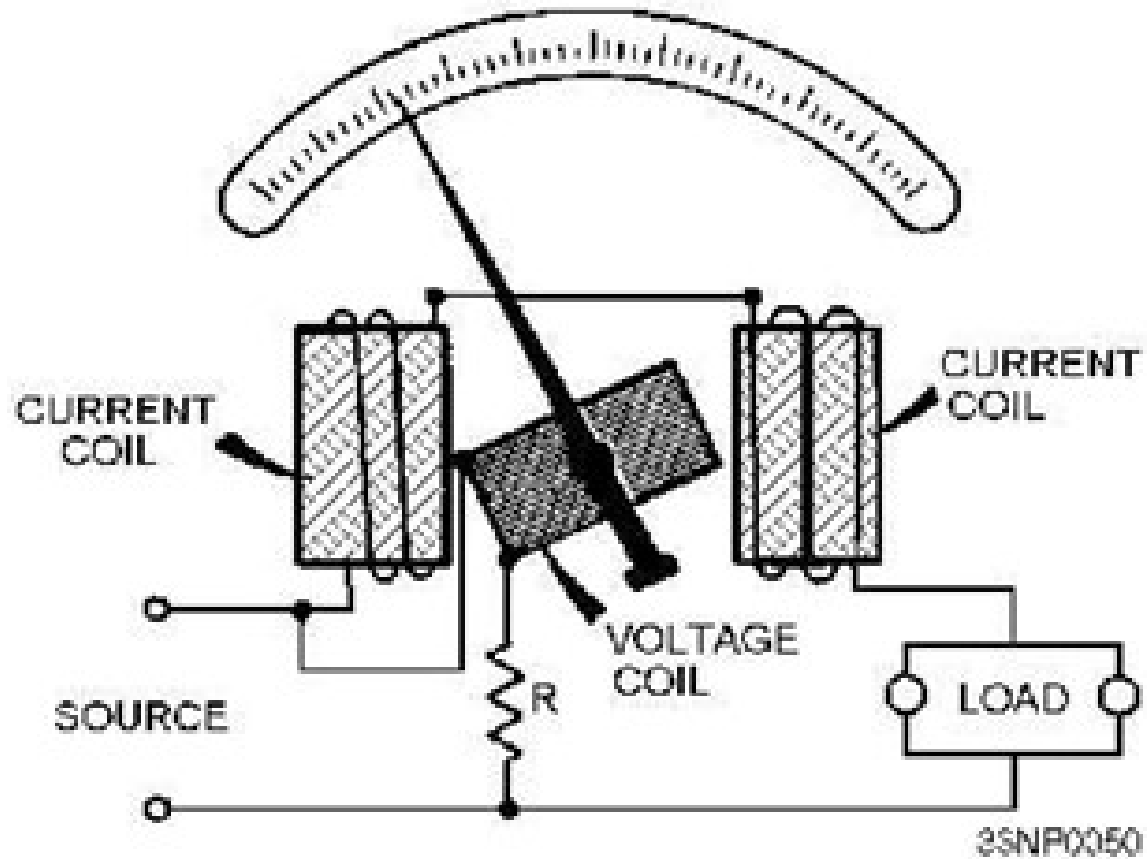

ELECTRODYNAMIC WATTMETER



ELECTRO-DYNAMIC WATTMETER

Advantages:

- Used for AC and DC.
- Easy in construction.
- Uniform scale.
- Light weight.
- Consume less power.

Disadvantages:

- High cost.
- Large errors occurs at low power factor.

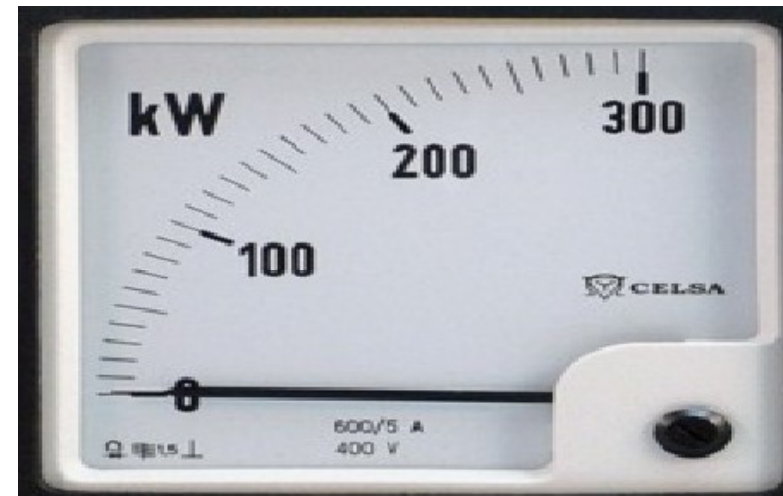



ENERGY METER

- **It is Recording Instrument**
- Used to measure the Electrical Energy consumed
- It is the first component fixed in the **ELECTRICITY CONSUMER POINT**
- Induction type energy meter is discussed here.
- Also called **KWH** meter





ENERGY METER

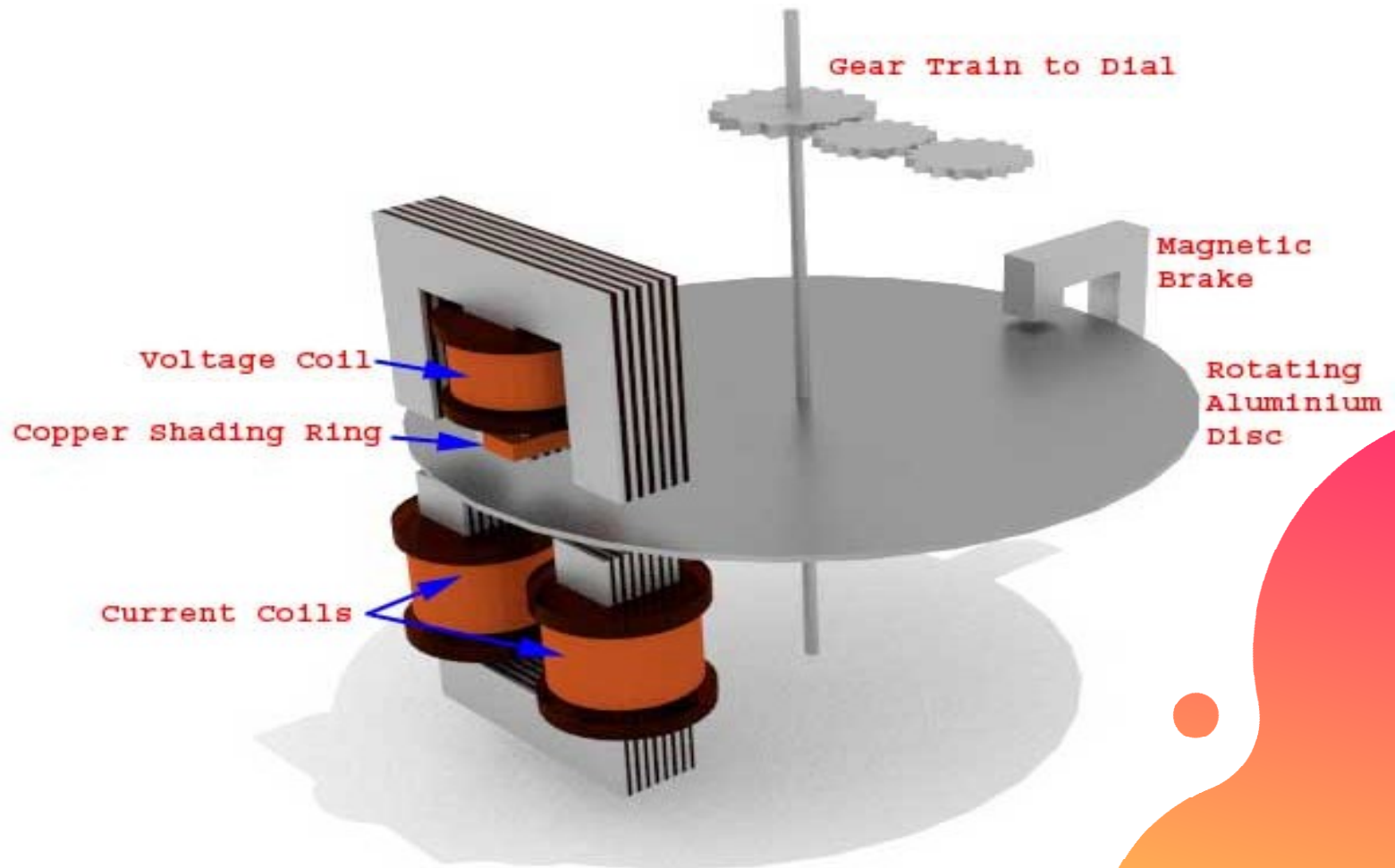



ENERGY METER

Construction:

- The two coils - **current coil (CC)** and voltage or **pressure coil (PC)**
- **Rotating disc** acts as a time counting device.
- The disc is kept free to rotate continuously.
- Speed of the disc depends on the power supplied to the load.
- More the load, higher is the disc speed.
- **A gear train** is provided to count the revolution of the disc.
- Number of revolution of the disc are directly recorded in terms of the energy consumed. (Recording instrument)



ENERGY METER

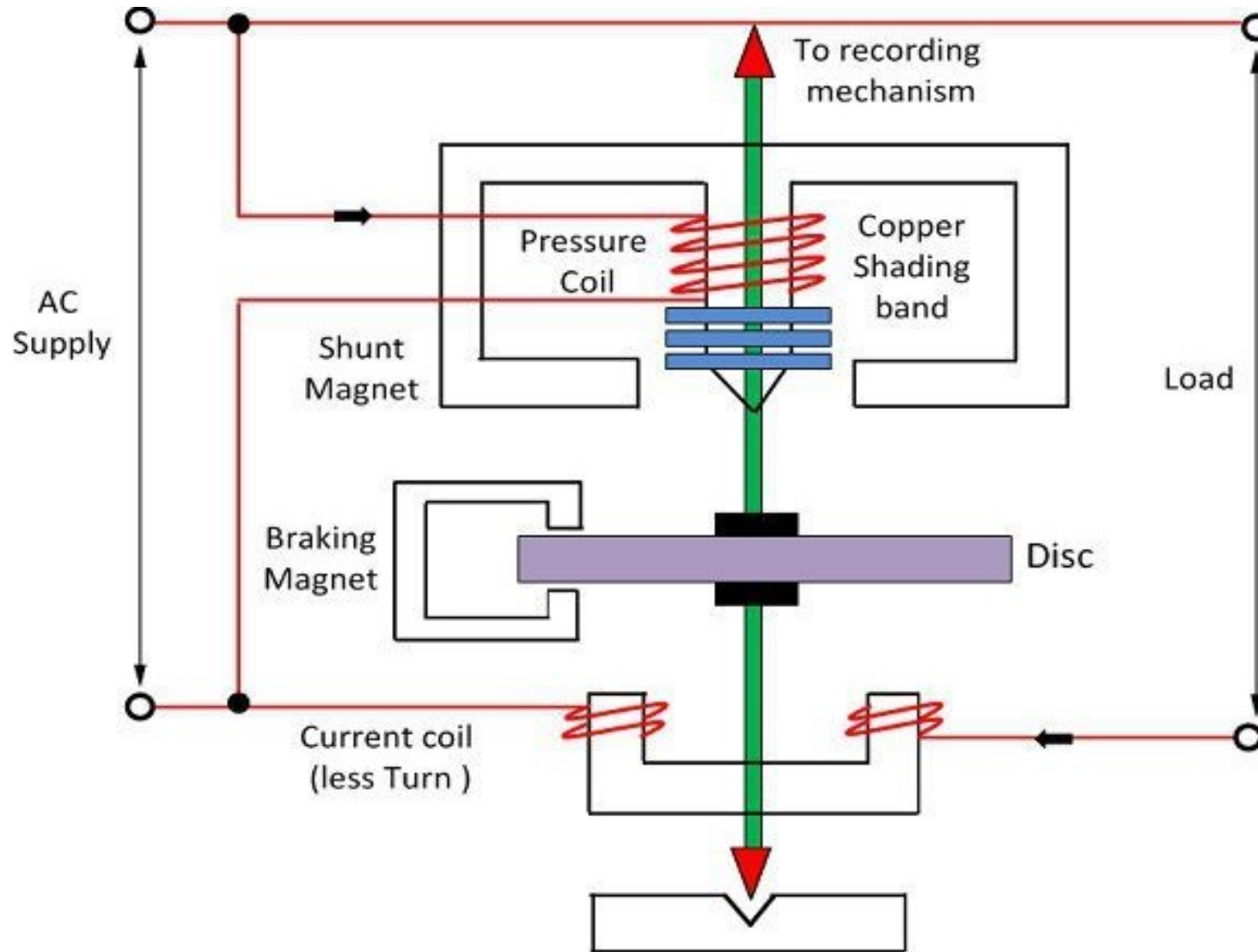



RECAP....



...THANK YOU