



SNS COLLEGE OF TECHNOLOGY

Coimbatore-35
An Autonomous Institution

Accredited by NBA – AICTE and Accredited by NAAC – UGC with 'A++' Grade
Approved by AICTE, New Delhi & Affiliated to Anna University, Chennai



DEPARTMENT OF ELECTRICAL AND ELECTRONICS ENGINEERING

19EET304/ IOT FOR ELECTRICAL SCIENCES

III YEAR VI SEM

UNIT 4 – ACTIVATION DEVICES

TOPIC 3 – Accelerometer and Gyroscope



Consider an example,



Uses the products



Gyro sensors

Gyro sensors, also known as angular rate sensors or angular velocity sensors, are devices that sense angular velocity.



Sensing devices that effectively augment human motion

Angular velocity

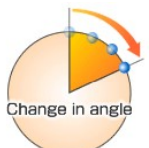

Change in angle

In simple terms, angular velocity is the change in rotational angle per unit of time. Angular velocity is generally expressed in deg/s (degrees per second).





gyroscope

The working principle of a gyroscope is based on gravity. It is explained as the product of angular momentum, which is experienced by the torque on a disc to produce a gyroscopic precession in the spinning wheel.

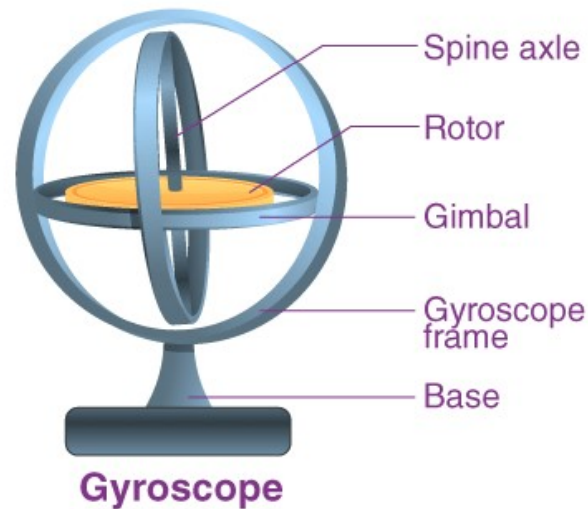



gyroscope



Gyroscope sensor is a device that can measure and maintain the orientation and angular velocity of an object. These are more advanced than accelerometers.

These can measure the tilt and lateral orientation of the object whereas accelerometer can only measure the linear motion.

Micro electromechanical systems, popularly known as MEMS, is the technology of very small electromechanical and mechanical devices.

Advance in MEMS technology has helped us to develop versatile products.





Gyroscope sensor



- Gyroscope sensors are also called as Angular Rate Sensor or Angular Velocity Sensors.
- These sensors are installed in the applications where the orientation of the object is difficult to sense by humans.
- Measured in degrees per second, angular velocity is the change in the rotational angle of the object per unit of time.





Gyroscope sensor-Working Principle

- Besides sensing the angular velocity, Gyroscope sensors can also measure the motion of the object.
- For more robust and accurate motion sensing, in consumer electronics Gyroscope sensors are combined with Accelerometer sensors.
- Depending on the direction there are three types of angular rate measurements.
- Yaw- the horizontal rotation on a flat surface when seen the object from above, Pitch- Vertical rotation as seen the object from front, Roll- the horizontal rotation when seen the object from front.



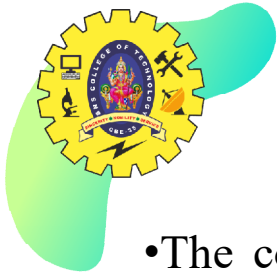

Gyroscope sensor-Working Principle

- The concept of Coriolis force is used in Gyroscope sensors. In this sensor to measure the angular rate, the rotation rate of the sensor is converted into an electrical signal.
- Working principle of Gyroscope sensor can be understood by observing the working of Vibration Gyroscope sensor.
- This sensor consists of an internal vibrating element made up of crystal material in the shape of a double – T- structure.
- This structure comprises a stationary part in the center with ‘Sensing Arm’ attached to it and ‘Drive Arm’ on both sides.





Gyroscope sensor-Working Principle

- This double-T-structure is symmetrical. When an alternating vibration electrical field is applied to the drive arms, continuous lateral vibrations are produced.
- As Drive arms are symmetrical, when one arm moves to left the other moves to the right, thus canceling out the leaking vibrations.
- This keeps the stationary part at the center and sensing arm remains static.
- When the external rotational force is applied to the sensor vertical vibrations are caused on Drive arms.
- This leads to the vibration of the Drive arms in the upward and downward directions due to which a rotational force acts on the stationary part in the center.



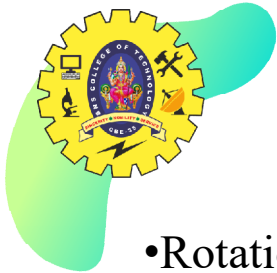

Contd...



- Rotation of the stationary part leads to the vertical vibrations in sensing arms.
- These vibrations caused in the sensing arm are measured as a change in electrical charge.
- This change is used to measure the external rotational force applied to the sensor as Angular rotation.



Gyroscope Sensor in Mobile

- To facilitate a good user experience nowadays smartphones are embedded with various types of sensors. These sensors also provide phone information about its surroundings and also helps in increased battery life.
- Steve Jobs was the first to use Gyroscope technology in consumer electronics. Apple iPhone was the first smartphone to have Gyroscope sensor technology.
- With the help of gyroscope in the smartphone, we can detect motion and gestures with our phones. Smartphones usually have an electronic version of the Vibration Gyroscope sensor.



Gyroscope-Types

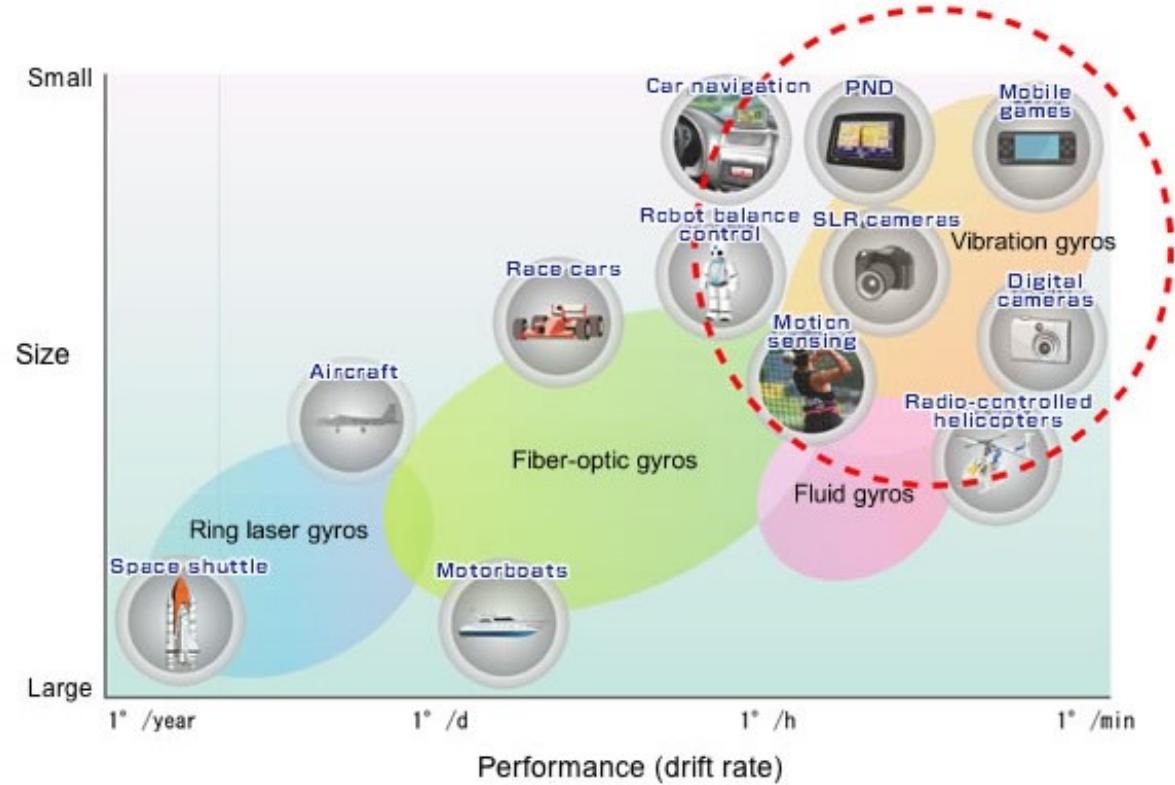

Miniature, high-accuracy vibration gyro sensors are indispensable.

ACCELEROMETER AND GYROSCOPE / 10EE1504-101 FOR ELECTRICAL SCIENCES/S.SHARWILABDE/SNSU





Acceleration associated with a single moving mass

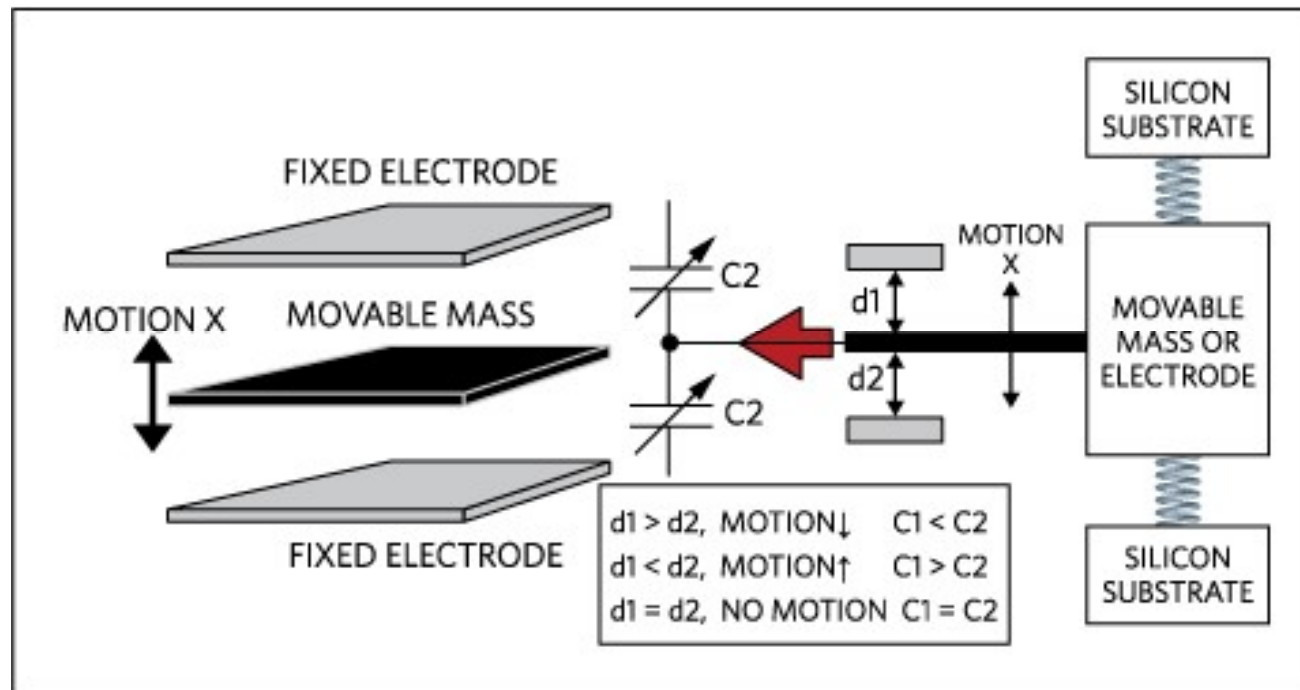



ASSESSMENT - 1

Imagine the Process

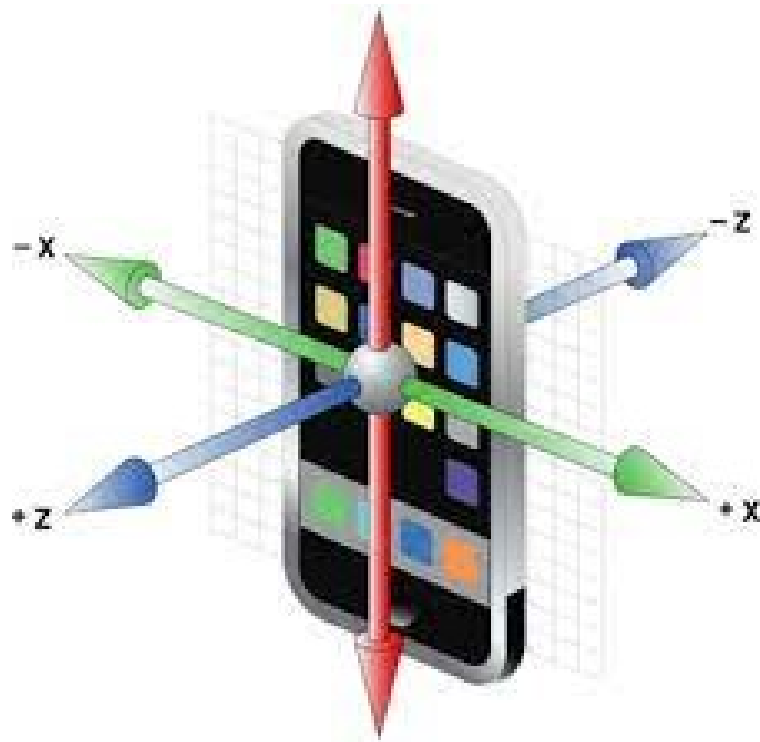



Acceleration associated with multiple moving masses

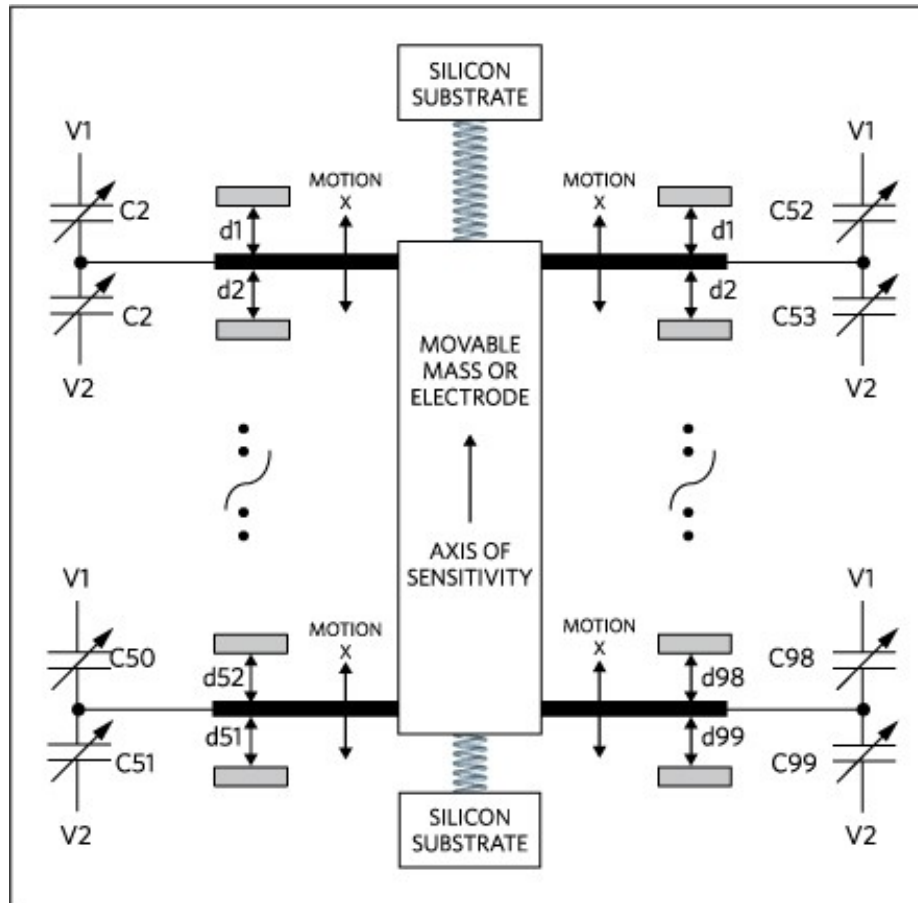

Electrical circuit of an accelerometer

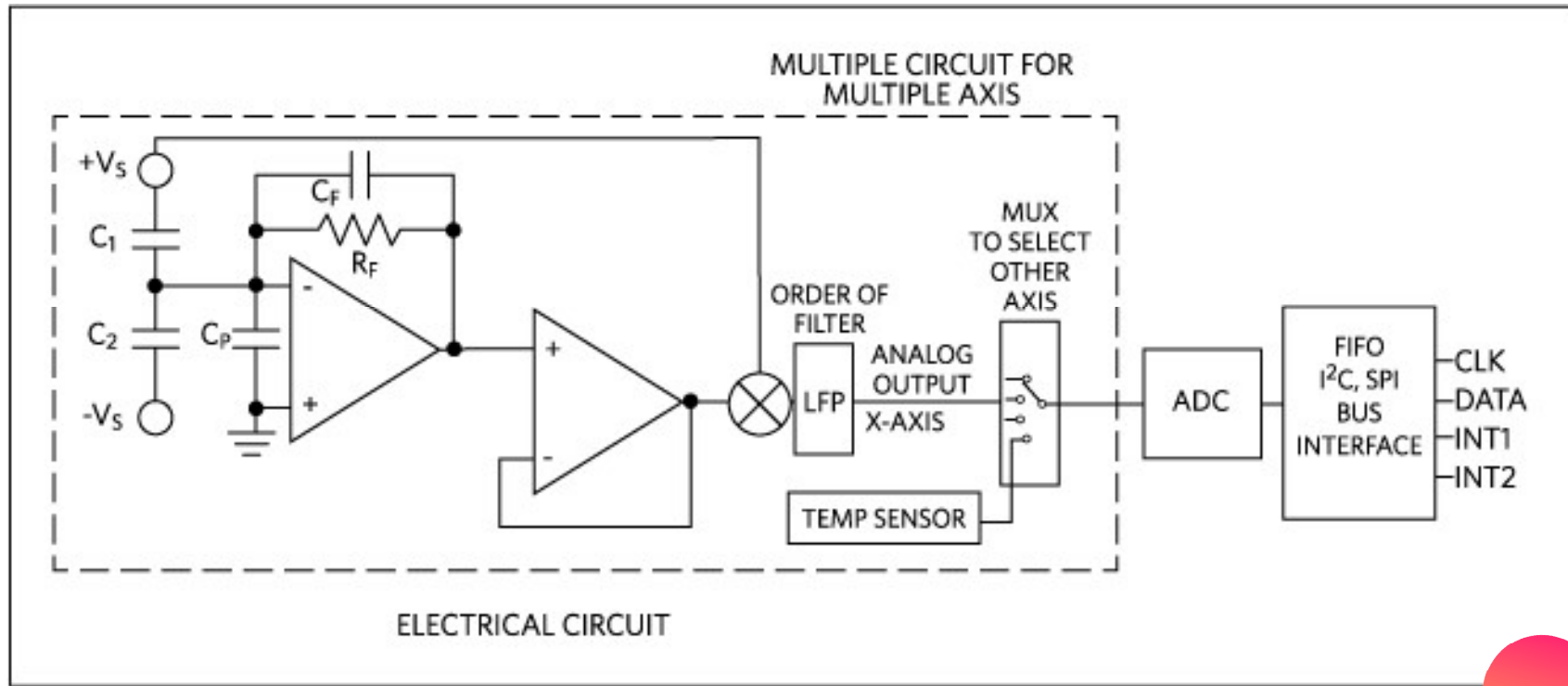



Applications of Gyroscope Sensor



It is used in any application where angular velocity, angle sensing, and control mechanisms are needed to be measured.

- **Sensing Angular Velocity** It can be used to sense the rate of change of angular motion in moving bodies. This can be used for detecting athletic movement.
- **Sensing Angles** The angles can also be detected using the gyroscope sensor. This application is used in car navigation and game controllers.
- **Sensing Control Mechanism** We can also use a gyroscopic sensor to detect vibration due to various external factors. We can use this application for camera-shake control and vehicle control.



ASSESSMENT - 2

Find the Process



References



- <https://www.elprocus.com/gyroscope-sensor/>
- https://www5.epsondevice.com/en/information/technical_info/gyro/
- <https://www.utmel.com/blog/categories/sensors/what-is-a-gyroscope-sensor>
- <https://www.ytl-e.com/news/quarterly-publication/what-is-the-function-and-working-principle-of-electronic-watthour-meter.html>





Thank You

