

UNIT- IV
8051 microcontroller

8051 microcontroller is designed by Intel in 1981. It is an 8-bit microcontroller. It is built with 40 pins DIP (dual inline package), 4kb of ROM storage and 128 bytes of RAM storage, 2 16-bit timers. It consists of are four parallel 8-bit ports, which are programmable as well as addressable as per the requirement. An on-chip crystal oscillator is integrated in the microcontroller having crystal frequency of 12 MHz.

Let us now discuss the architecture of 8051 Microcontroller.

In the following diagram, the system bus connects all the support devices to the CPU. The system bus consists of an 8-bit data bus, a 16-bit address bus and bus control signals. All other devices like program memory, ports, data memory, serial interface, interrupt control, timers, and the CPU are all interfaced together through the system bus.

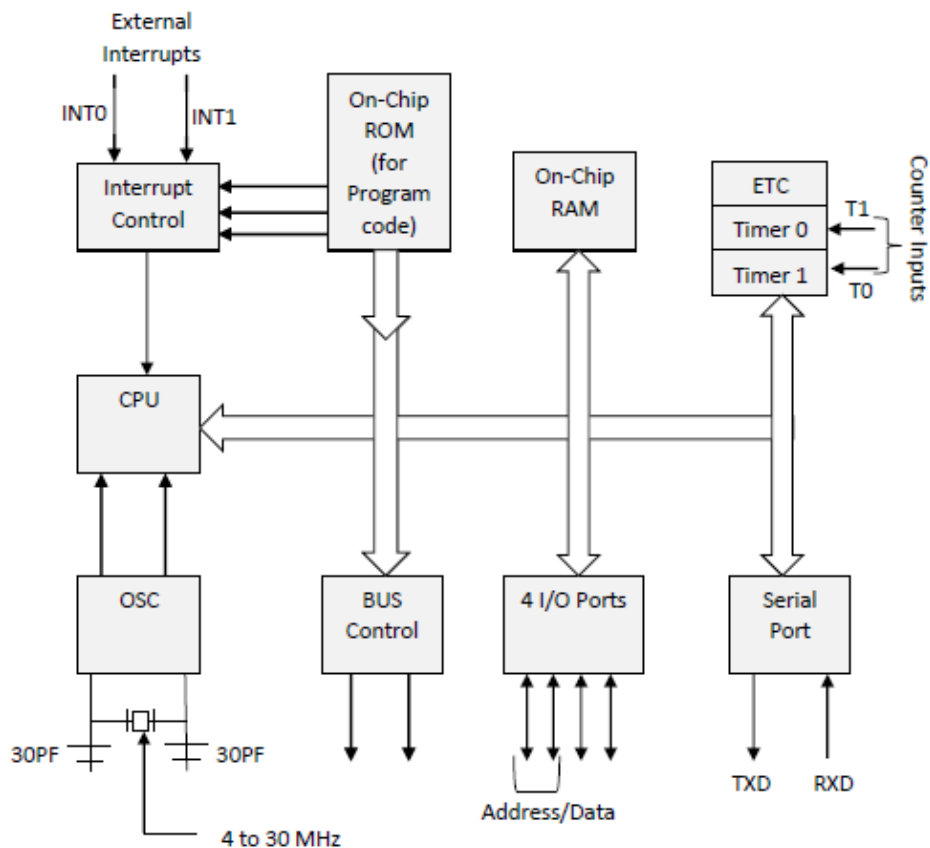

The pin diagram of 8051 microcontroller looks as follows –

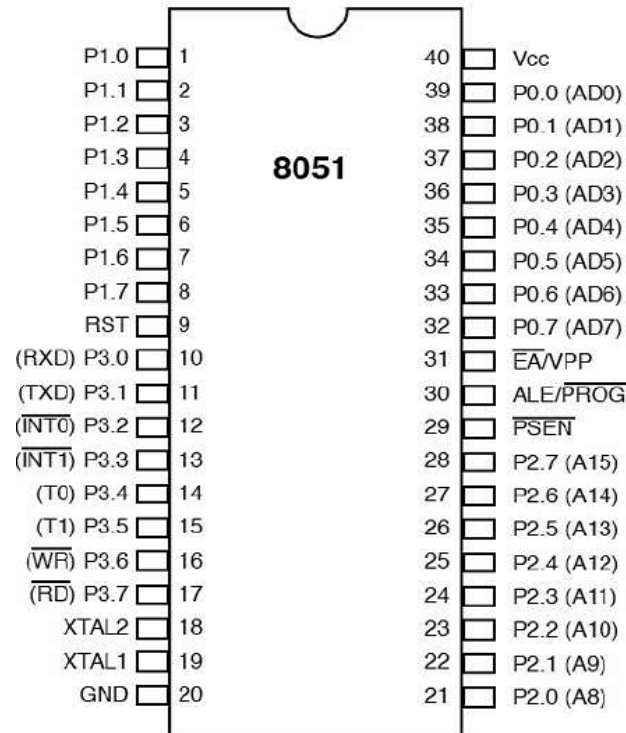

- **Pins 1 to 8** – These pins are known as Port 1. This port doesn't serve any other functions. It is internally pulled up, bi-directional I/O port.
- **Pin 9** – It is a RESET pin, which is used to reset the microcontroller to its initial values.
- **Pins 10 to 17** – These pins are known as Port 3. This port serves some functions like interrupts, timer input, control signals, serial communication signals RxD and TxD, etc.
- **Pins 18 & 19** – These pins are used for interfacing an external crystal to get the system clock.
- **Pin 20** – This pin provides the power supply to the circuit.
- **Pins 21 to 28** – These pins are known as Port 2. It serves as I/O port. Higher order address bus signals are also multiplexed using this port.
- **Pin 29** – This is PSEN pin which stands for Program Store Enable. It is used to read a signal from the external program memory.
- **Pin 30** – This is EA pin which stands for External Access input. It is used to enable/disable the external memory interfacing.
- **Pin 31** – This is ALE pin which stands for Address Latch Enable. It is used to demultiplex the address-data signal of port.
- **Pins 32 to 39** – These pins are known as Port 0. It serves as I/O port. Lower order address and data bus signals are multiplexed using this port.
- **Pin 40** – This pin is used to provide power supply to the circuit.

Instruction Format

- An **instruction** is a command to the microprocessor to perform a given task on a specified data. Each instruction has two parts: one is task to be performed, called the **operation code** (opcode), and the second is the data to be operated on, called the **operand**. The operand (or data) can be