



SNS COLLEGE OF TECHNOLOGY, COIMBATORE –35



Decision Trees



Decision Tree



Decision tree —model algorithms that use comparisons:

- internal nodes represent comparisons
- leaves represent outcomes

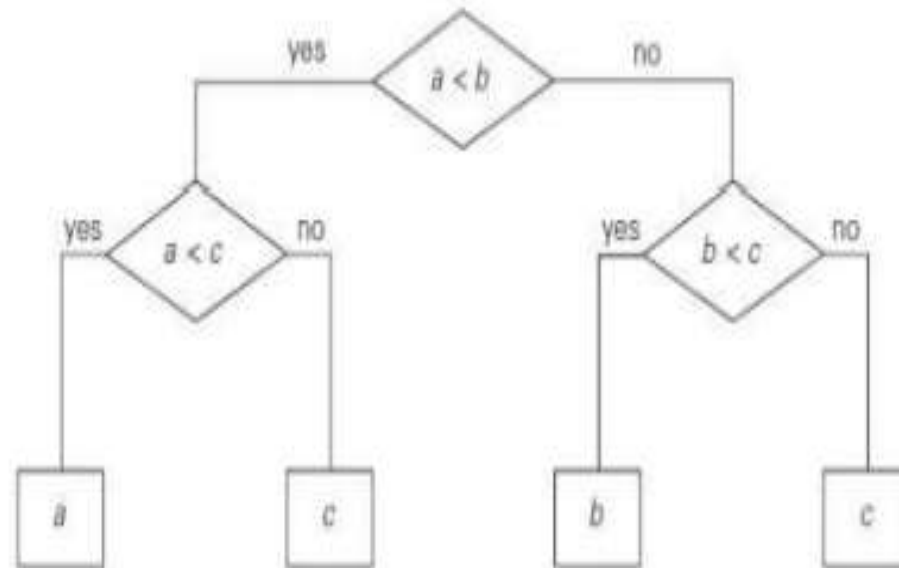

FIGURE 11.1 Decision tree for finding a minimum of three numbers.



Decision Tree & Sorting Algorithms



- Any comparison-based sorting algorithm can be represented by a decision tree (for each fixed n)
- Number of leaves (outcomes) $\geq n!$
- Height of binary tree with $n!$ leaves $\geq \lceil \log_2 n! \rceil$
- Minimum number of comparisons in the worst case $\geq \lceil \log_2 n! \rceil$ for any comparison-based sorting algorithm, since the longest path represents the worst case and its length is the height
- $\lceil \log_2 n! \rceil \approx n \log_2 n$ (by Sterling approximation)
- This lower bound is tight (mergesort or heapsort)



Decision Tree & Sorting Algorithms

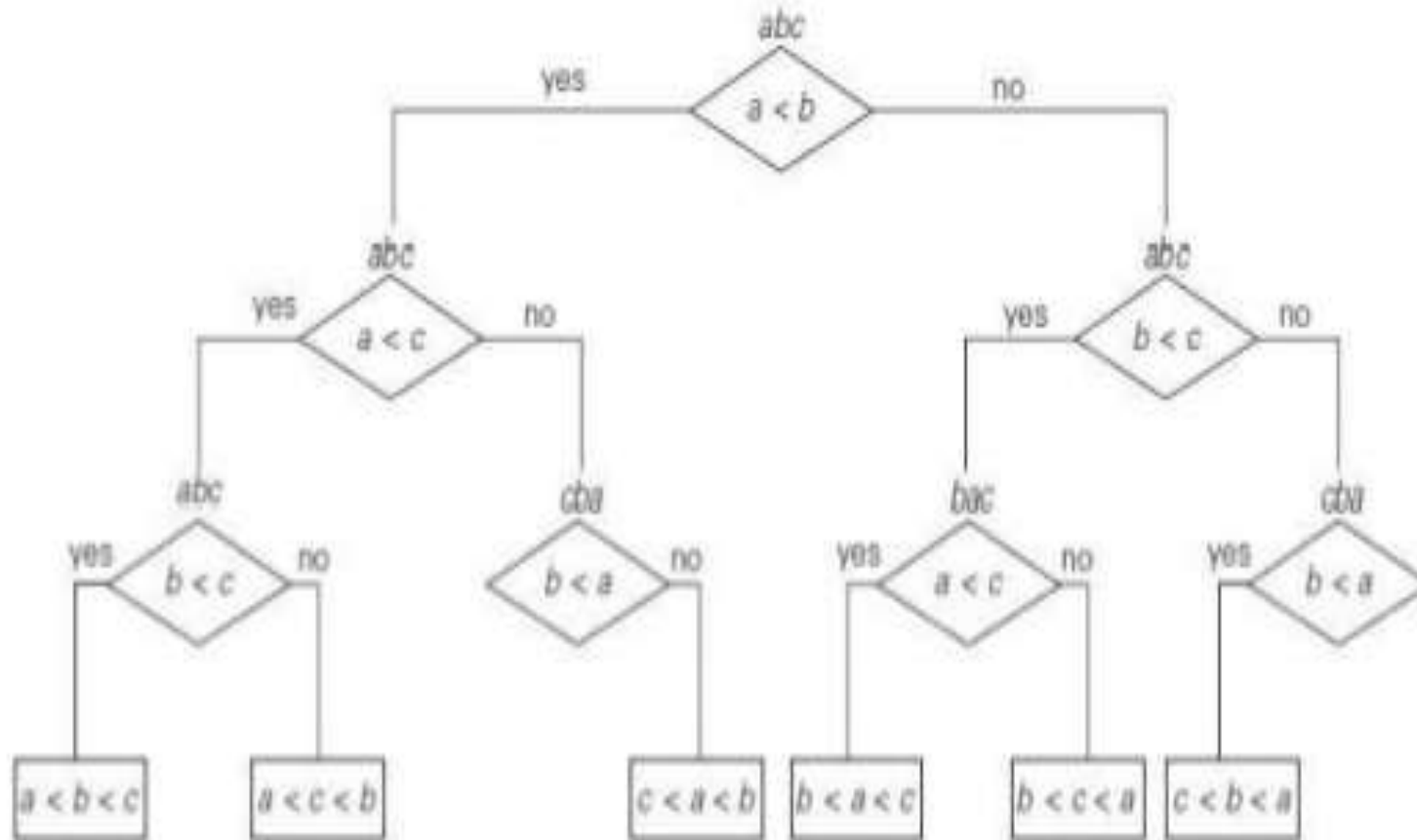
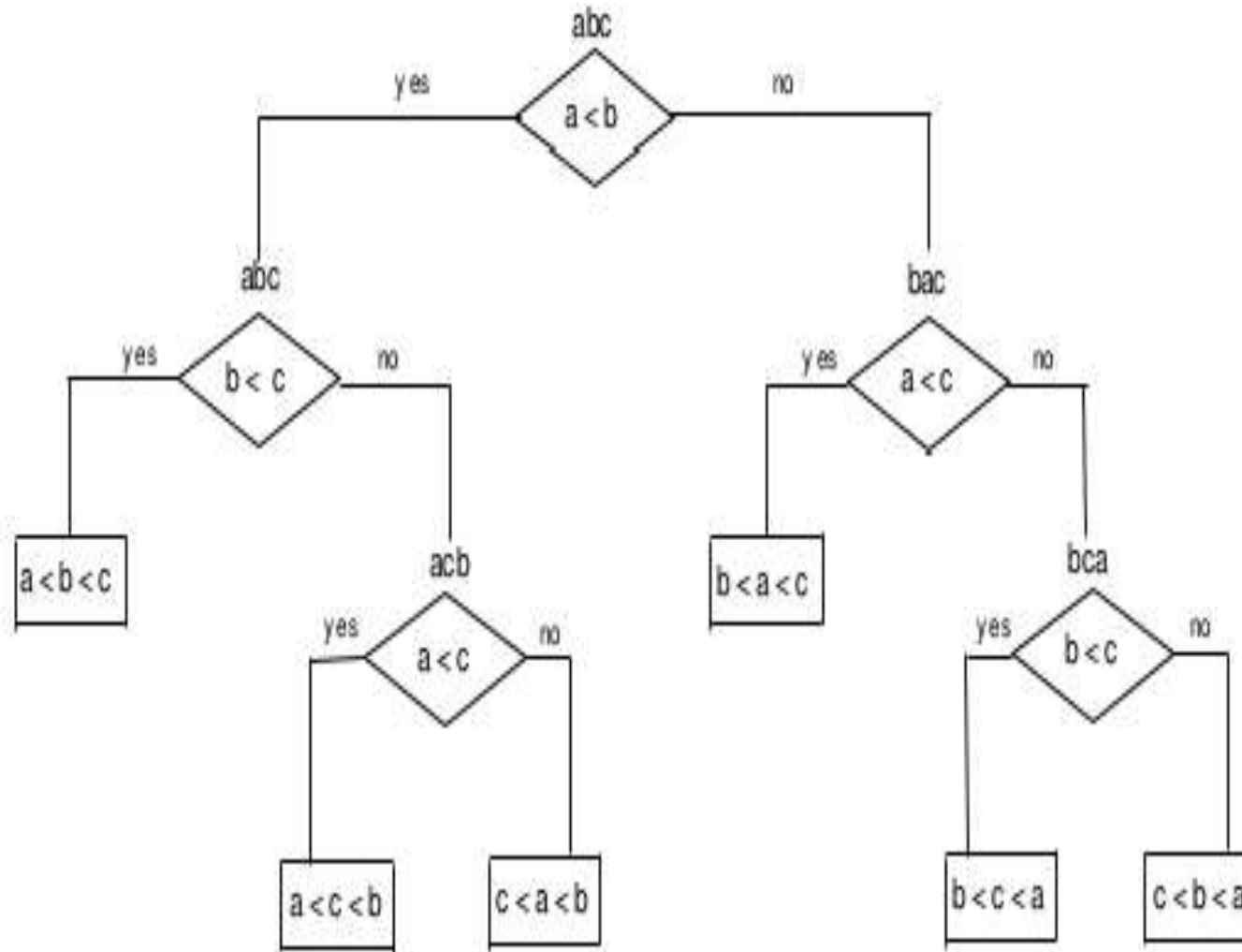

FIGURE 11.2 Decision tree for the tree-element selection sort. A triple above a node indicates the state of the array being sorted. Note two redundant comparisons $b < a$ with a single possible outcome because of the results of some previously made comparisons.



Insertion Sort





Binary Search

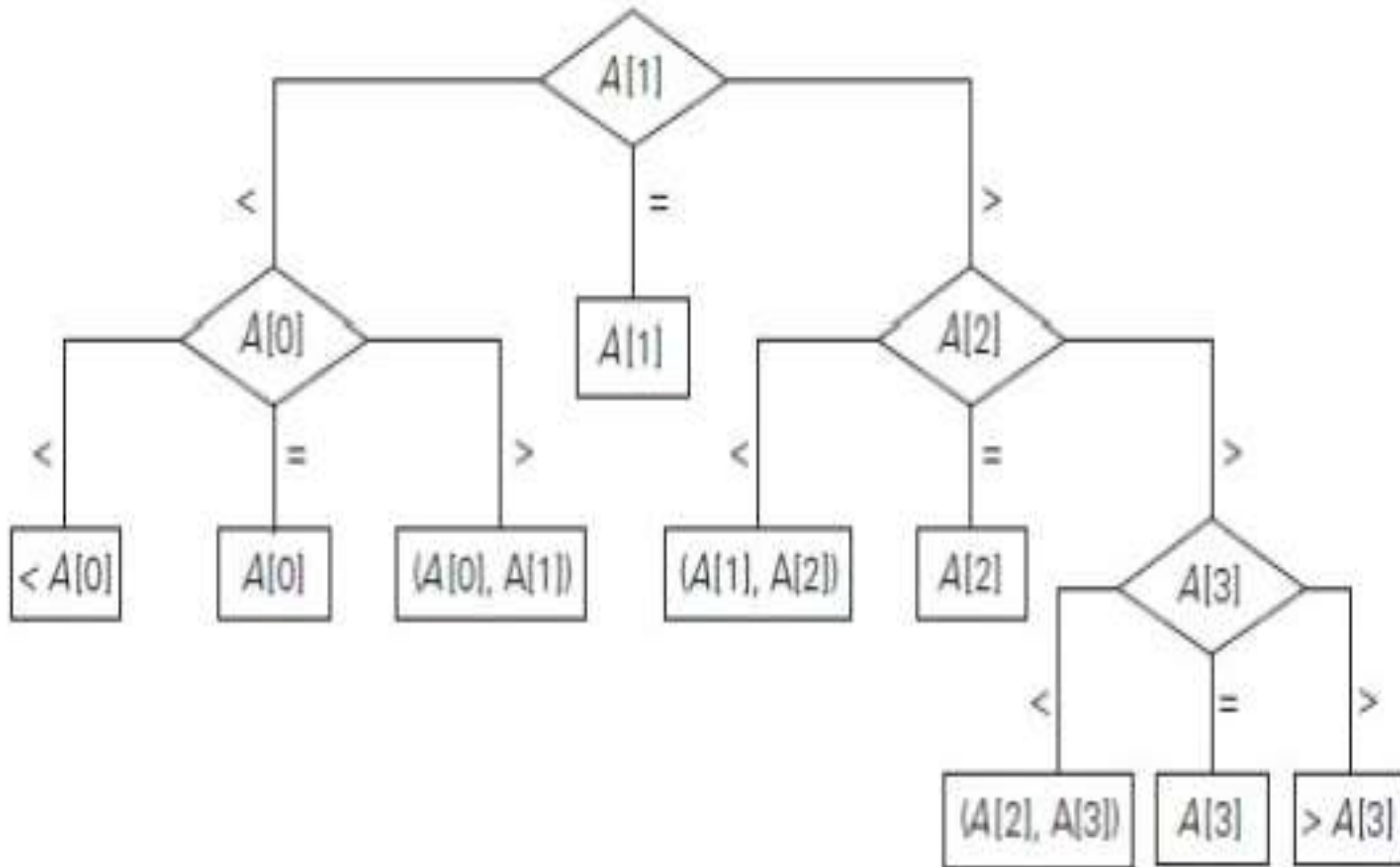

FIGURE 11.4 Ternary decision tree for binary search in a four-element array.



Binary Search

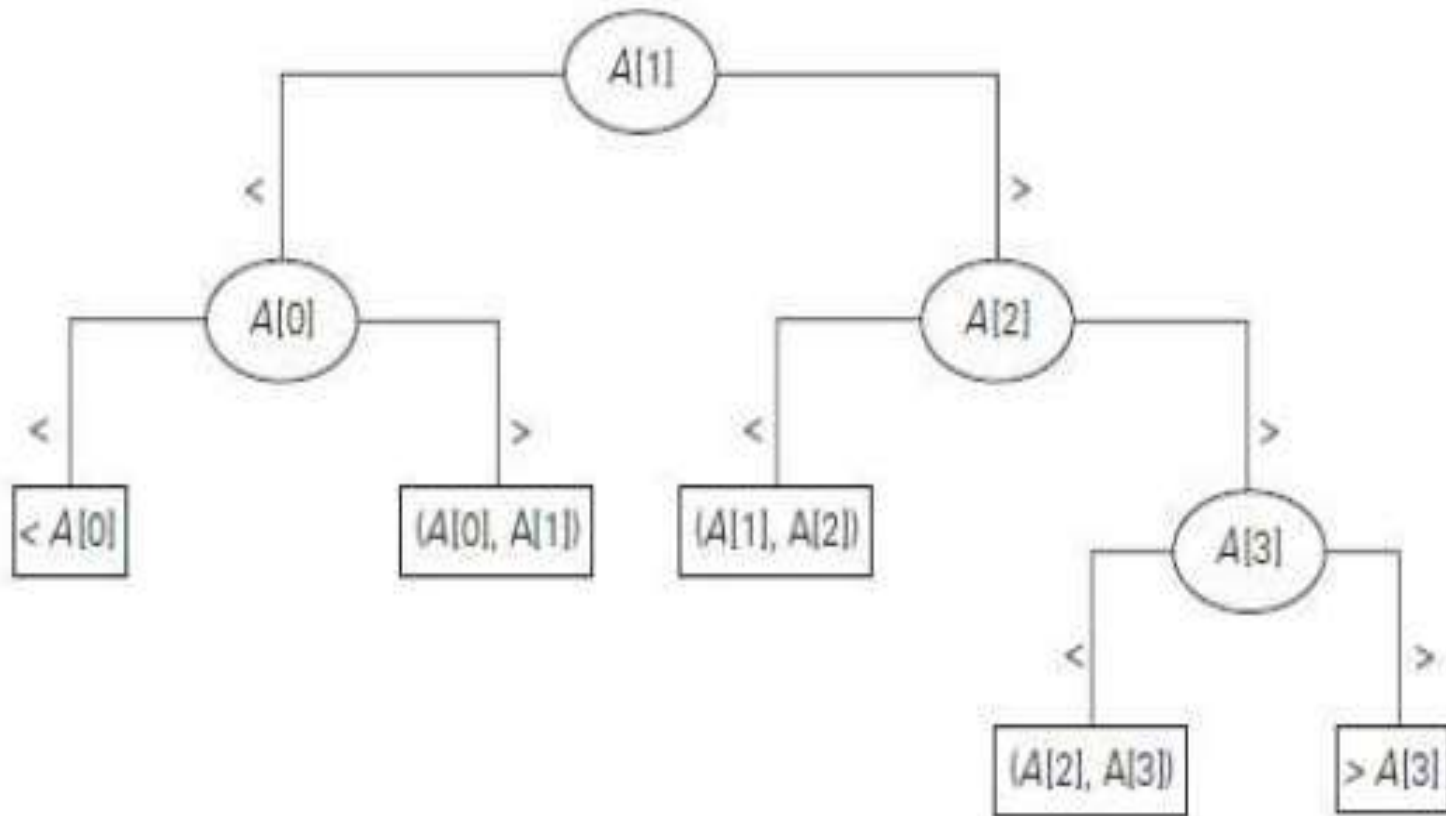

FIGURE 11.5 Binary decision tree for binary search in a four-element array.