



SNS COLLEGE OF TECHNOLOGY
An Autonomous Institution
Coimbatore-35



Accredited by NBA – AICTE and Accredited by NAAC – UGC with 'A++' Grade
Approved by AICTE, New Delhi & Affiliated to Anna University, Chennai

DEPARTMENT OF ELECTRONICS & COMMUNICATION ENGINEERING

19ECB212 – DIGITAL SIGNAL PROCESSING

II YEAR/ IV SEMESTER

UNIT 5 – DSP APPLICATIONS

TOPIC – SAMPLING RATE CONVERSION BY A RATIONAL FACTOR I/D &
APPLICATIONS OF MULTIRATE DSP



SAMPLING RATE CONVERSION BY A RATIONAL FACTOR I/D



- In decimation and interpolation, the sampling rate conversion is achieved by integer factor (because D and I are integers)
- When sampling rate conversion is required by non-integer factor, it is possible to perform sampling rate conversion by a rational factor $1/D$
- The Sampling rate conversion by a factor $1/D$, involves the following steps
 1. Perform interpolation by a factor I
 2. Filter the output of interpolator using a lowpass filter (anti-imaging filter) with bandwidth π/I



SAMPLING RATE CONVERSION BY A RATIONAL FACTOR I/D



3. The output of anti-imaging filter is passed through another lowpass filter (anti-aliasing filter) to limit the bandwidth of the signal to π/D
4. Finally the signal bandlimited to π / D is decimated by a factor D
 - The process of sampling rate conversion by a factor I/D is shown. In order to preserve the spectral characteristics of $x(n)$, the interpolation has to be performed first and decimation has to be performed next
 - The two lowpass filters with bandwidth π/I and π/D can be combined to a single lowpass filter with a bandwidth minimum among π/I , π/D as shown



SAMPLING RATE CONVERSION BY A RATIONAL FACTOR I/D

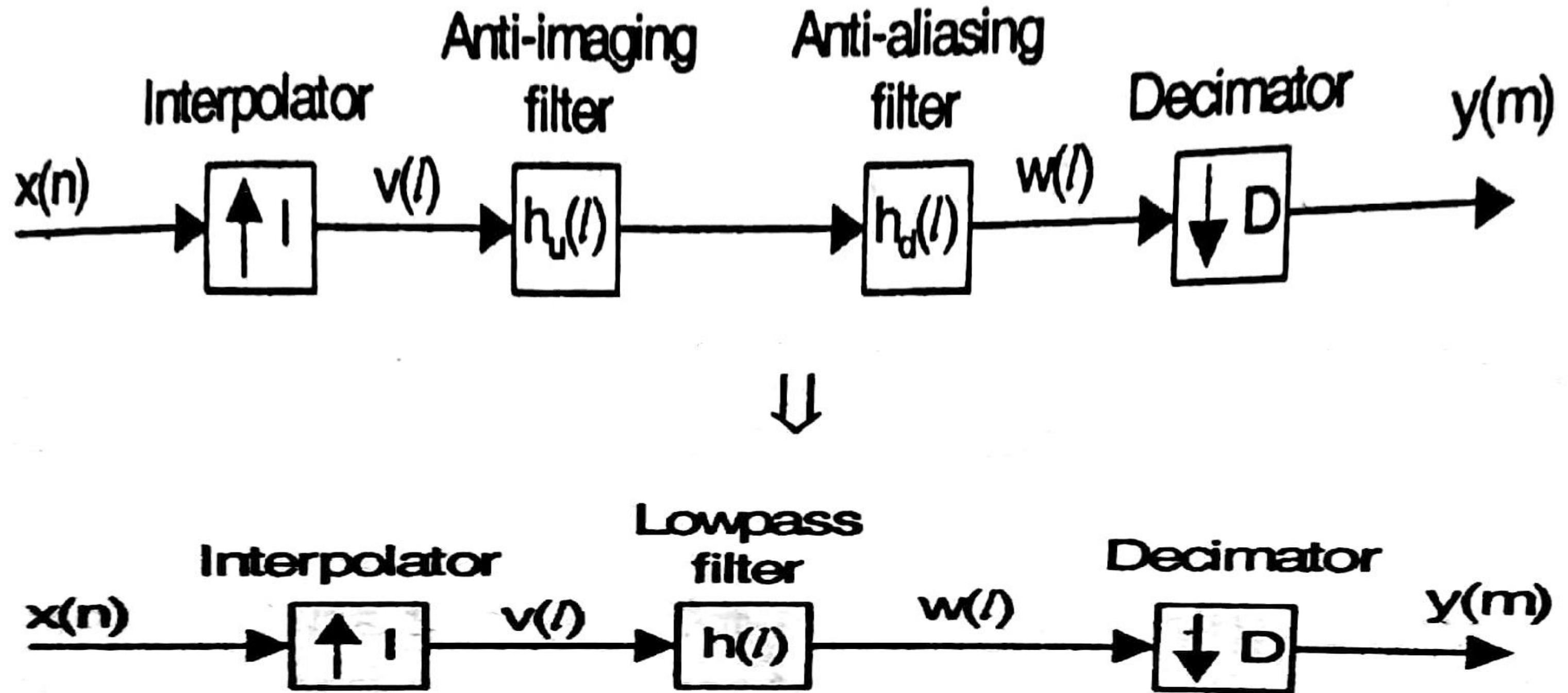



SPECTRUM OF SAMPLING RATE CONVERTER BY A RATIONAL FACTOR I/D



- Consider the sampling rate converter, which performs sampling rate conversion by a factor I/D . Here, the discrete time signal $x(n)$ is first upsampled by an integer factor I , then bandlimited using a lowpass filter and finally downsampled by an integer factor D

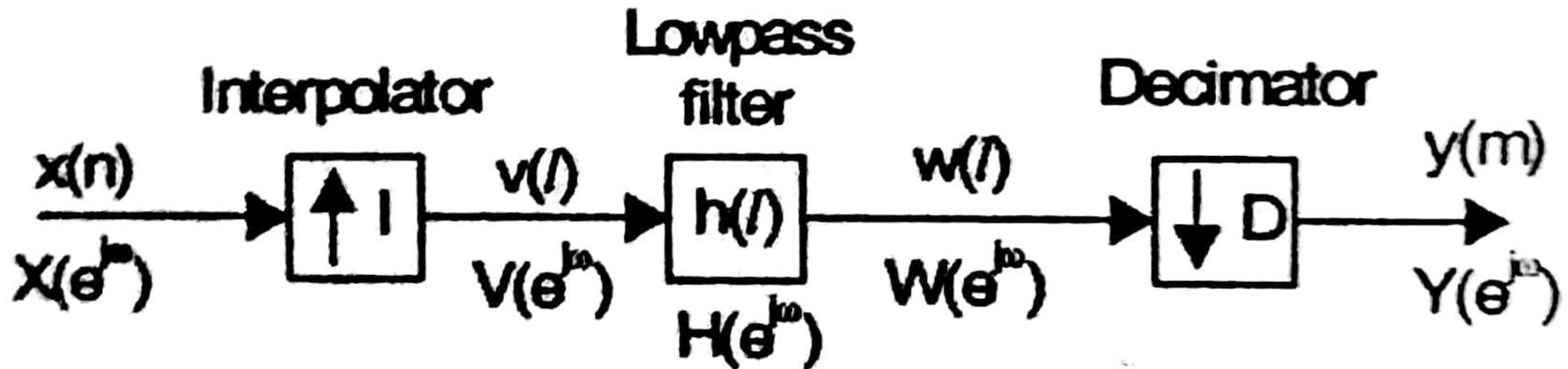



SPECTRUM OF SAMPLING RATE CONVERTER BY A RATIONAL FACTOR I/D



- Let, $x(n)$ = Input signal
- $x(n/I) = v(l) =$ Upsampled version of $x(n)$
- $w(l) =$ Bandlimited version of $v(l)$
- $w(Dl) = y(m) =$ Decimated version of $w(l)$
- Let $X(e^{j\omega})$, $V(e^{j\omega})$, $W(e^{j\omega})$ and $Y(e^{j\omega})$ are spectrum of the signals $x(n)$, $v(l)$, $w(l)$ and $y(m)$ respectively
- For interpolation by an integer factor I , the frequency spectrum of output signal of interpolator is given by equation

$$V(e^{j\omega}) = X(e^{j\omega I})$$



APPLICATIONS OF MULTIRATE DSP



- **Digital Filter Banks:** A digital filter bank is a set of bandpass filters. The digital filter banks can be classified into two types. They are
 1. Analysis filter banks
 2. Synthesis filter banks
- **Analysis Filter Banks:** An analysis filter bank is a set of bandpass filters with common input as shown. The analysis filter bank is used for spectrum analysis in which a signal is divided into a set of sub-band signals
- The analysis filter bank consists of M numbers of sub-band filters so that the input signal $x(n)$ is divided into M -numbers of sub-band signals $v_0(n), v_1(n), v_2(n), \dots, v_{M-1}(n)$



APPLICATIONS OF MULTIRATE DSP



- Here $H_0(z)$, $H_1(z)$, $H_2(z)$, $H_{M-1}(z)$ are transfer function of M-numbers of bandpass filters.
- **Synthesis Filter Banks:** A synthesis filter bank is a set of bandpass filters used to combine or synthesis a number of sub-band signals into a single composite signal as shown
- The analysis filter bank accepts M numbers of sub-band filters $w_0(n)$, $w_1(n)$, $w_2(n)$, $w_{M-1}(n)$ combined to give a signal $y(n)$
- In fact the synthesis filter bank perform the reverse process of analysis filter bank. Here $G_0(z)$, $G_1(z)$, $G_2(z)$, $G_{M-1}(z)$ are transfer function of M-numbers of bandpass filters.



APPLICATIONS OF MULTIRATE DSP



Analysis Filter Bank

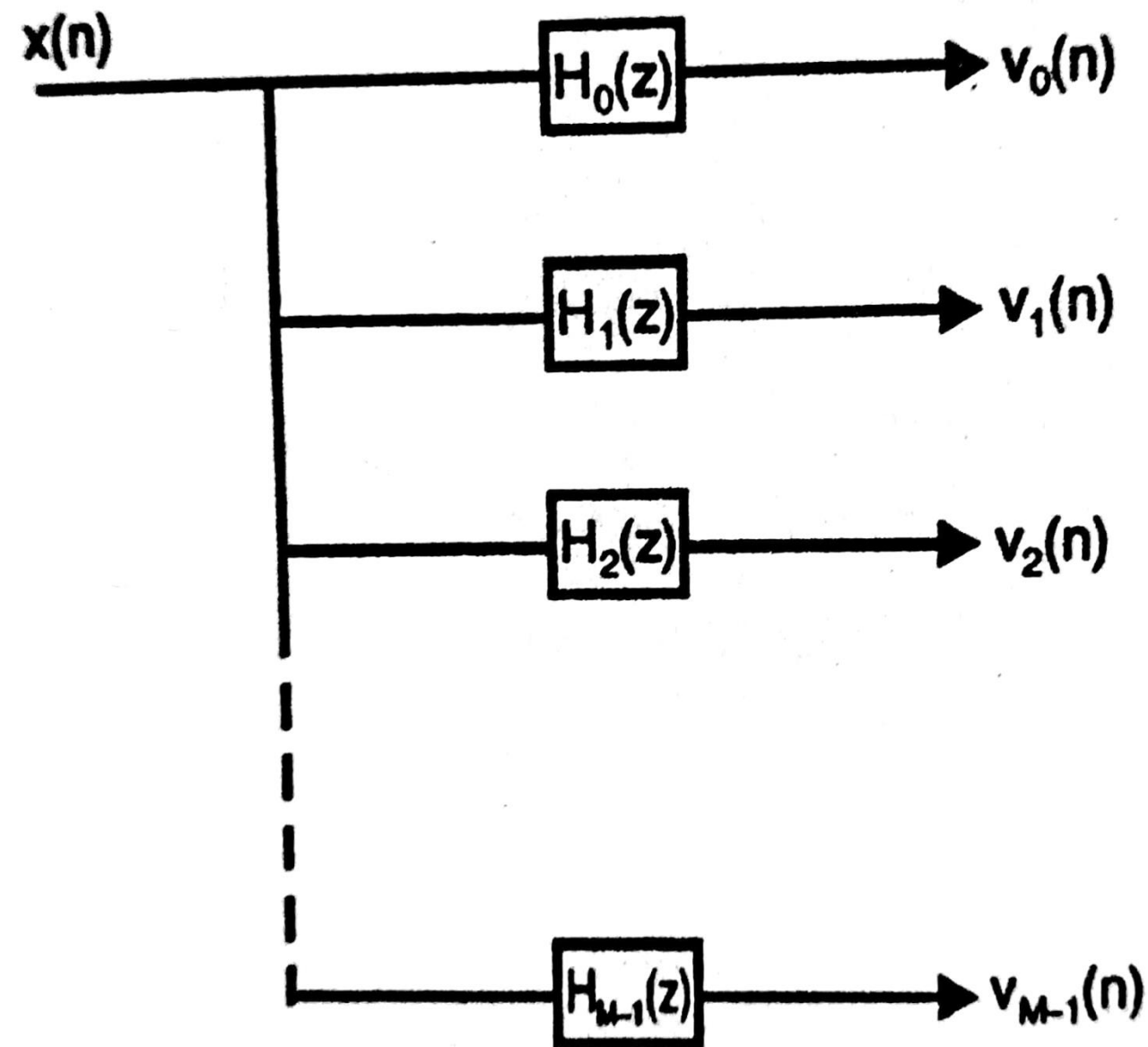

Synthesis Filter Bank

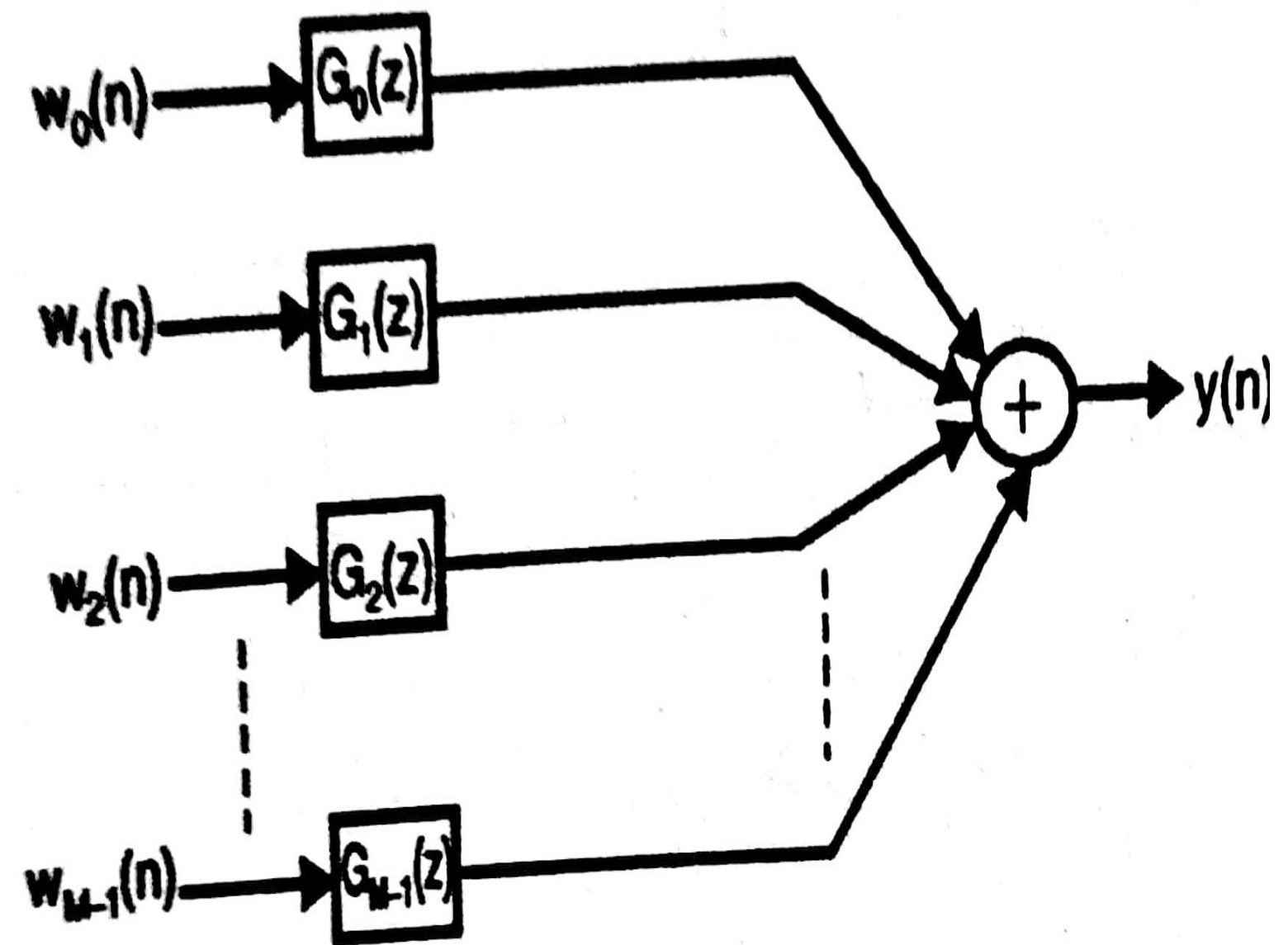



SUB-BAND CODING OF SPEECH SIGNALS



- In sub-band coding of speech signals, the speech signals is divided into sub-bands, decimated, encoded and transmitted to the receiver system
- On the receiver side the sub-band signals are decoded, interpolated and synthesized into the original speech signal
- In the transmission side, the input signal is split into M-numbers of non-overlapping frequency bands using an analysis filter bank consisting of M-numbers of bandpass filters. The output of each bandpass filter is decimated by a factor of D. The output of decimators are encoded and transmitted
- On the reception side, the received sub-band signals are decoded and then interpolated to recover the missing samples



SUB-BAND CODING OF SPEECH SIGNALS



- The output of interpolators are applied to a synthesis filter bank consisting of M-numbers of bandpass filters to recover the original signal

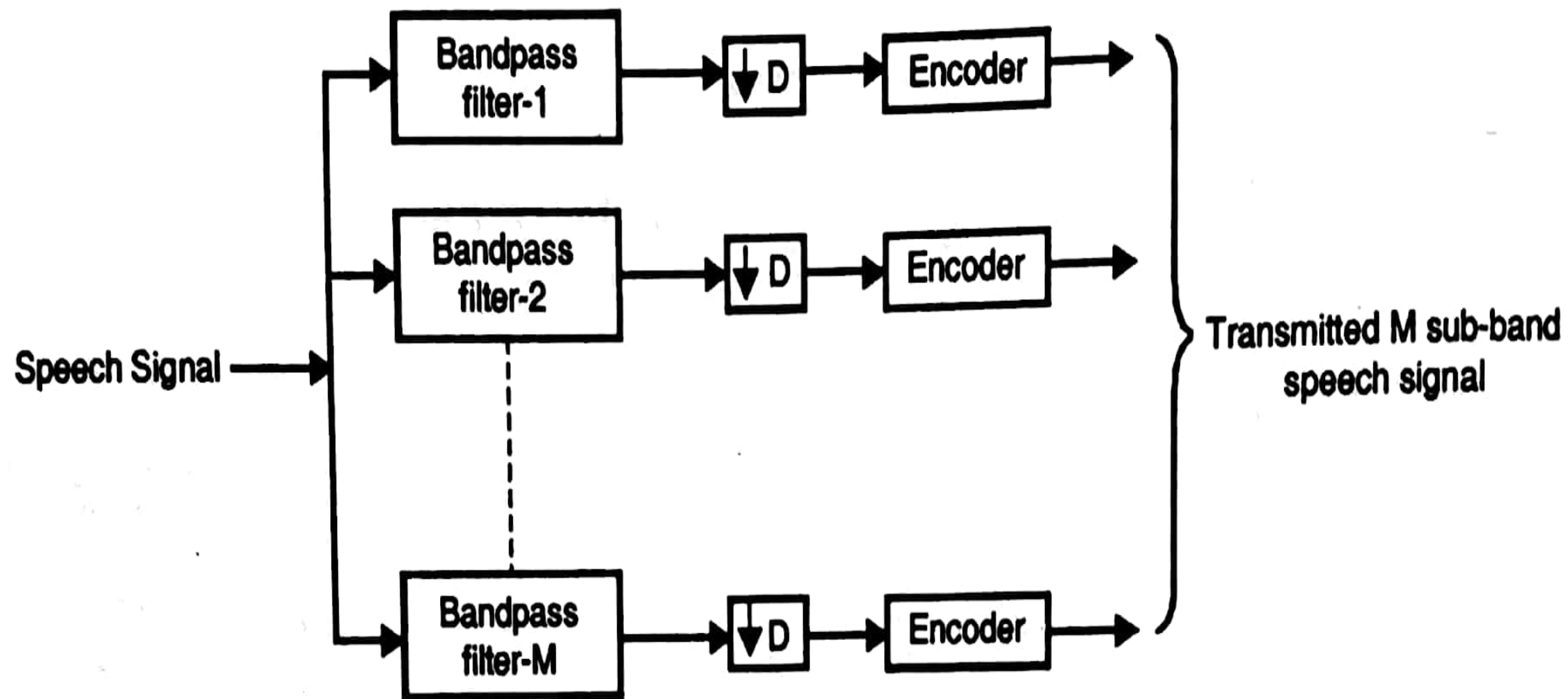



SUB-BAND CODING OF SPEECH SIGNALS

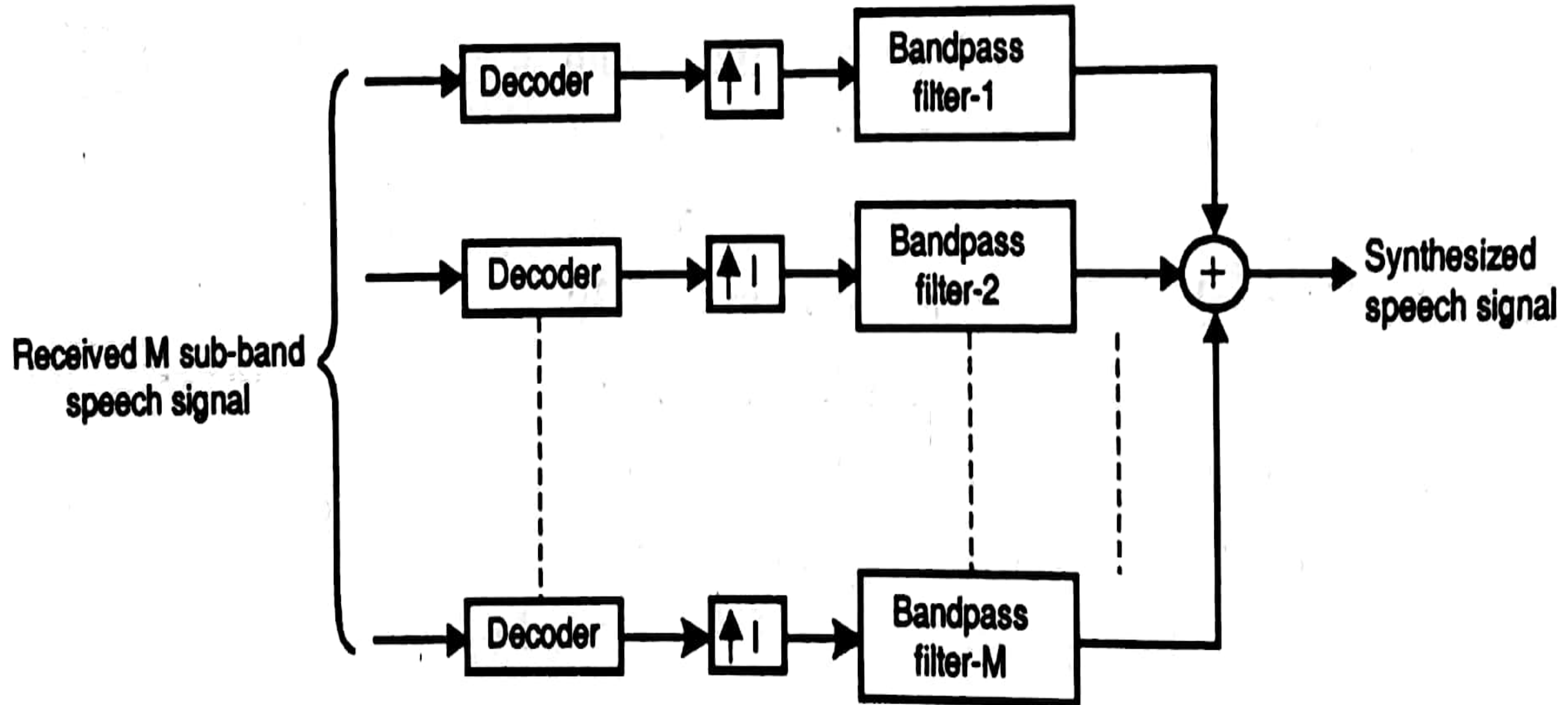



QUADRATURE MIRROR FILTER (QMF) BANK



- The QMF banks are filter banks with complementary frequency response. The basic building blocks of QMF bank is a two channel quadrature mirror filter (QMF)
- A two channel QMF consists of an analysis section and a synthesis section as shown

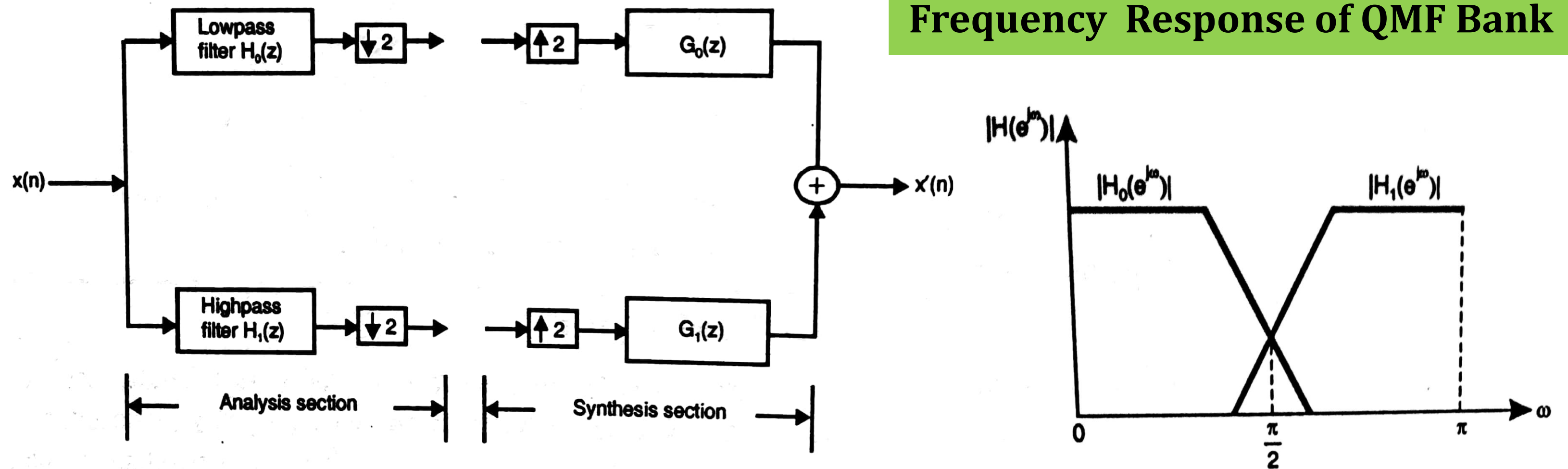



QUADRATURE MIRROR FILTER (QMF) BANK



- The analysis section consists of a lowpass filter and highpass filter with symmetrical frequency response with centre of symmetry at $\pi/2$ as shown. The output of the filters of analysis section are decimated by 2 and transmitted
- In the synthesis section, the received signals are upsampled/interpolated by 2 and passed through two filters, whose frequency responses are selected to exactly cancel the effect of aliasing due to decimation by spectrum imaging due to interpolation
- The main advantage of QMF filter is that the aliasing resulting from decimation in the analysis section is exactly cancelled by the image signal spectrum that arises due to interpolation. Hence the two-channel QMF section behaves as a linear time invariant system



ASSESSMENT



1. In decimation and interpolation, the sampling rate conversion is achieved by -----
2. In order to preserve the spectral characteristics of $x(n)$, the ----- has to be performed first and ----- has to be performed next
3. Define Digital Filter Bank.
4. The digital filter banks can be classified into two types. They are ----- and -----
5. A two channel QMF consists of an ----- section and ----- section



THANK YOU