

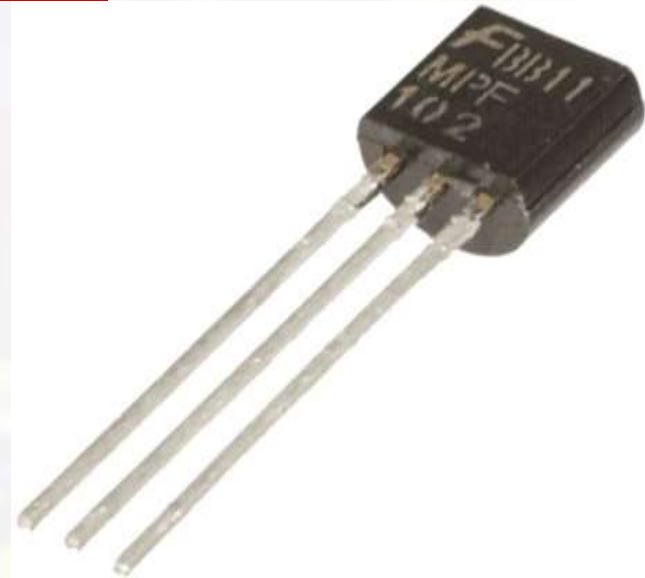

UNIT IV



JUNCTION FIELD EFFECT TRANSISTOR



Introduction (FET)

- Field-effect transistor (FET) are important devices such as BJTs
- Also used as amplifier and logic switches
- What is the difference between JFET and BJT?



BJT is Current-controlled

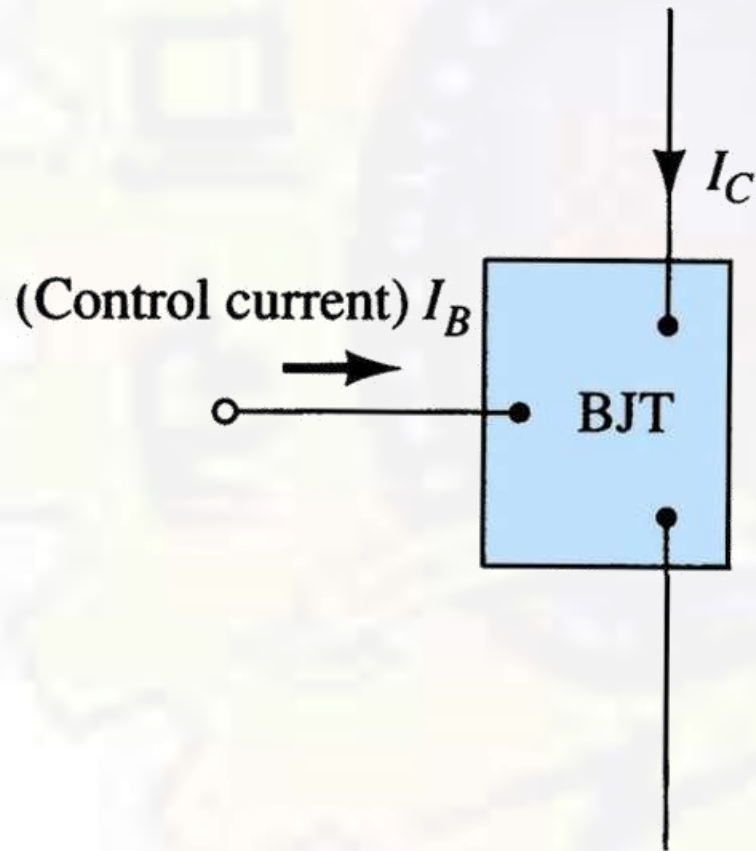



FET is Voltage-controlled

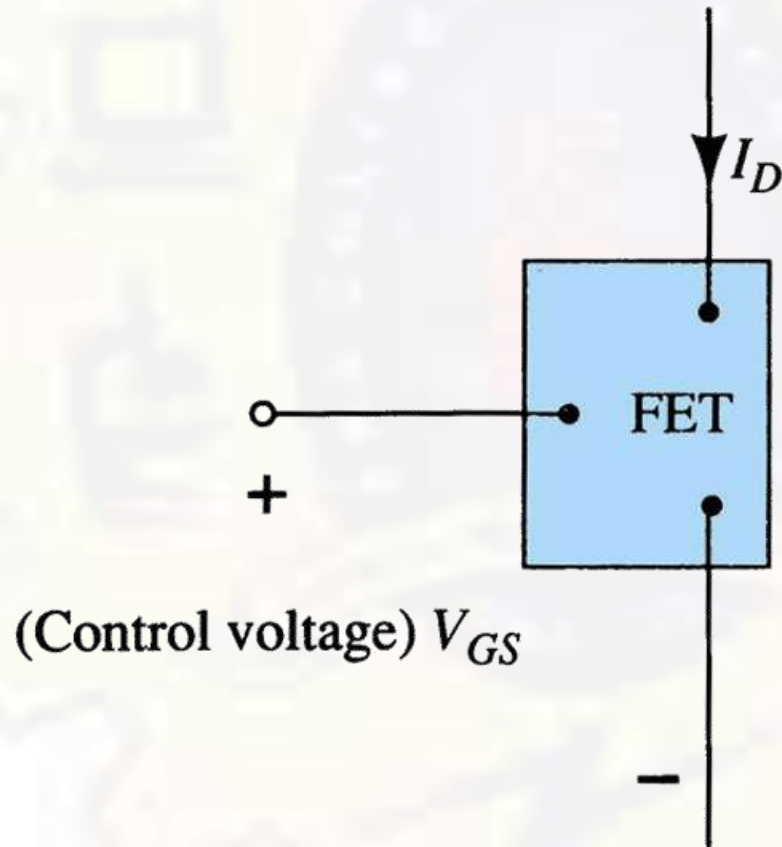



Types of Field Effect Transistors (The Classification)

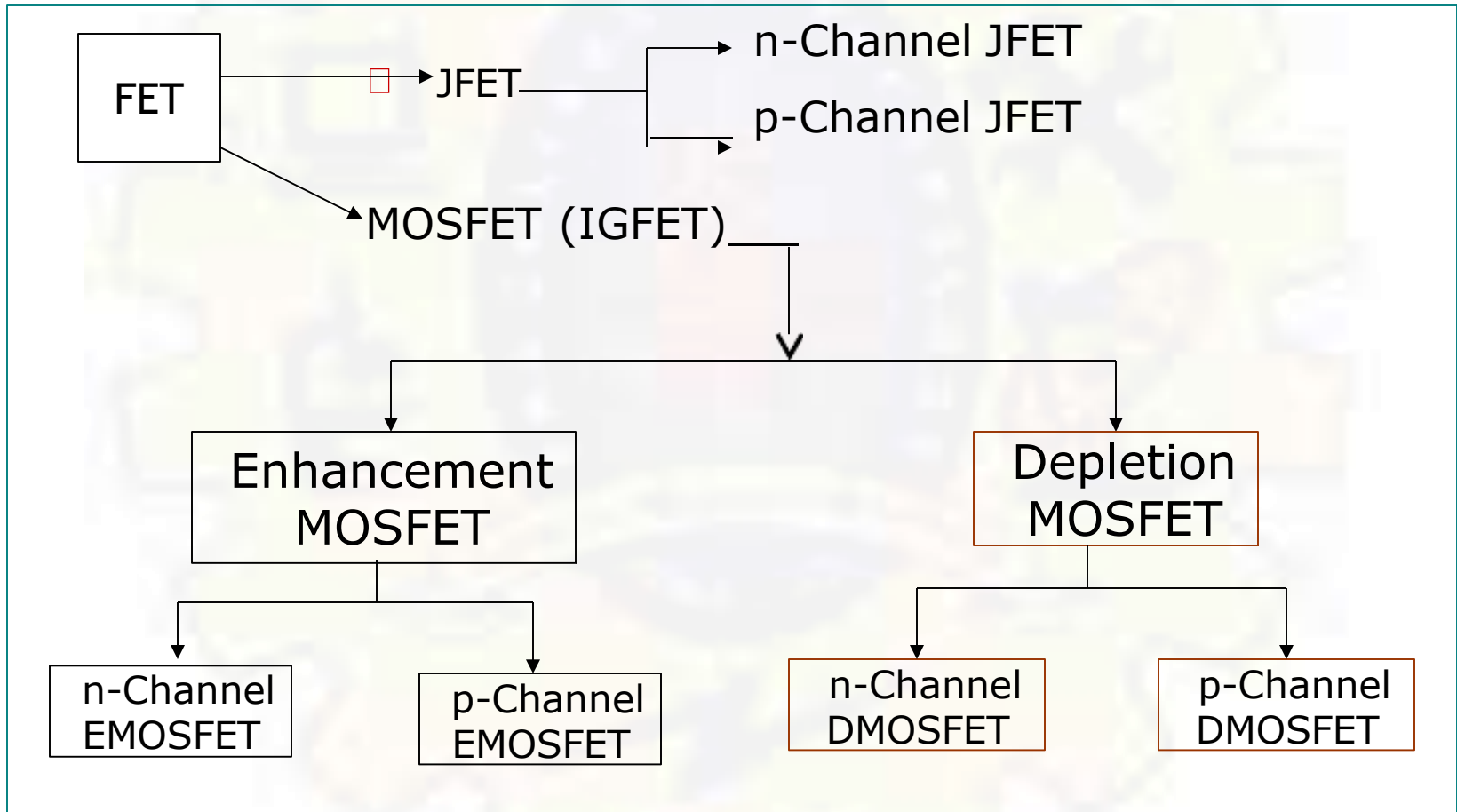



Introduction.. (Advantages of FET over BJT)



- High input impedance ($M\Omega$)
(Linear AC amplifier system)
- Temperature stable than BJT
- Smaller than BJT
- Can be fabricated with fewer processing
- BJT is bipolar – conduction both hole and electron
- FET is unipolar – uses only one type of current carrier
- Less noise compare to BJT
- Usually use as an Amplifier and logic switch



Disadvantages of FET

- Easy to damage compare to BJT



Junction field-effect transistor..

- There are 2 types of **JFET**
 - n-channel JFET
 - p-channel JFET

- Three Terminal
 - Drain – D
 - Gate -G
 - Source – S



SYMBOLS

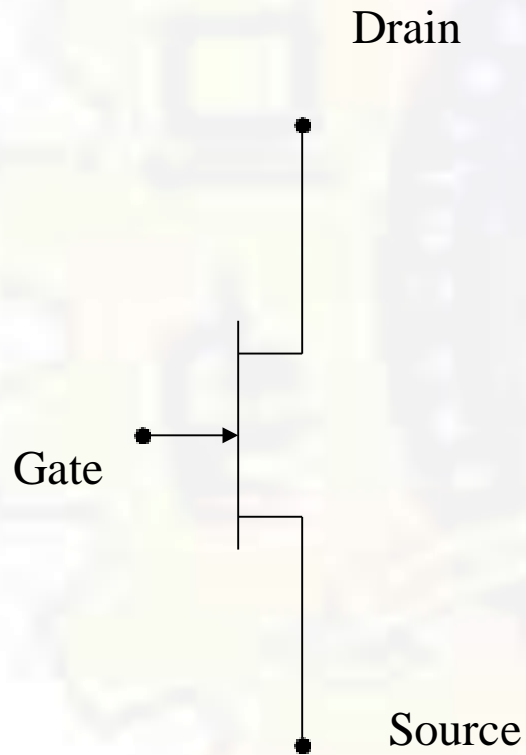

n-channel JFET

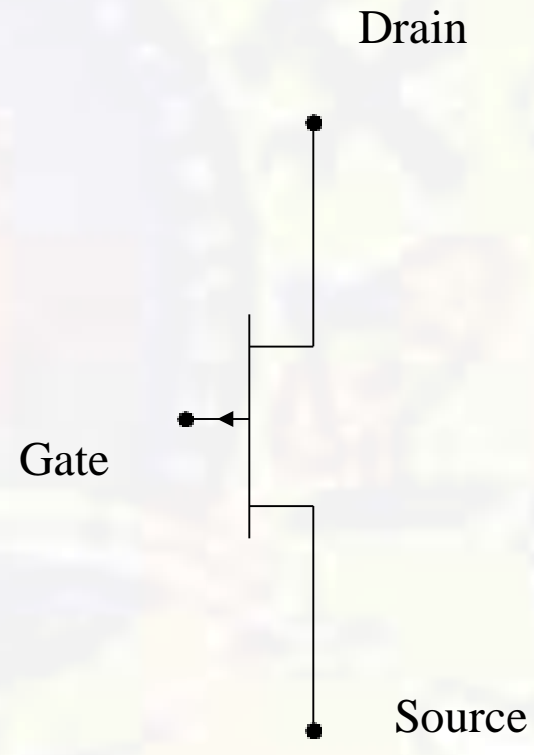

p-channel JFET



N-channel JFET

- **N channel JFET**
- Major structure is **n-type material (channel)** between embedded **p-type material** to form 2 p-n junction.
- In the normal operation of an n-channel device, the **Drain (D)** is positive with respect to the **Source (S)**. Current flows into the Drain (D), through the channel, and out of the Source (S)
- Because the resistance of the channel depends on the **gate-to-source voltage (V_{GS})**, the **drain current (I_D)** is controlled by that voltage



N-channel JFET..

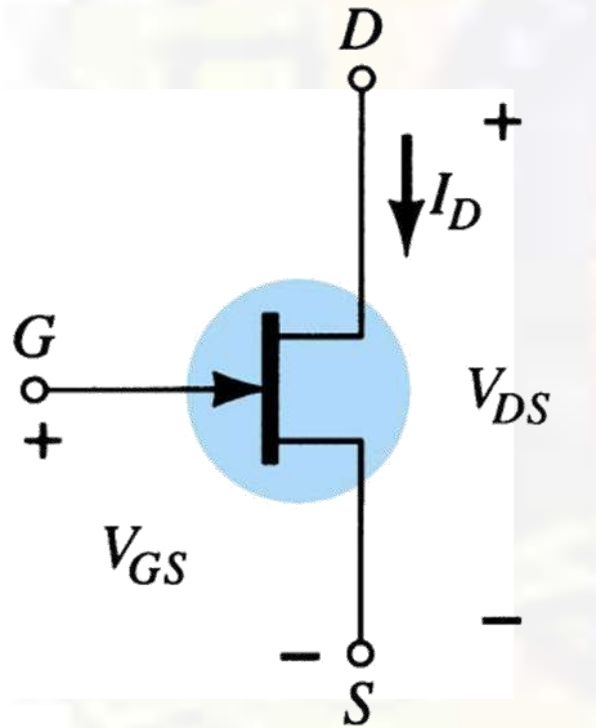

(a)

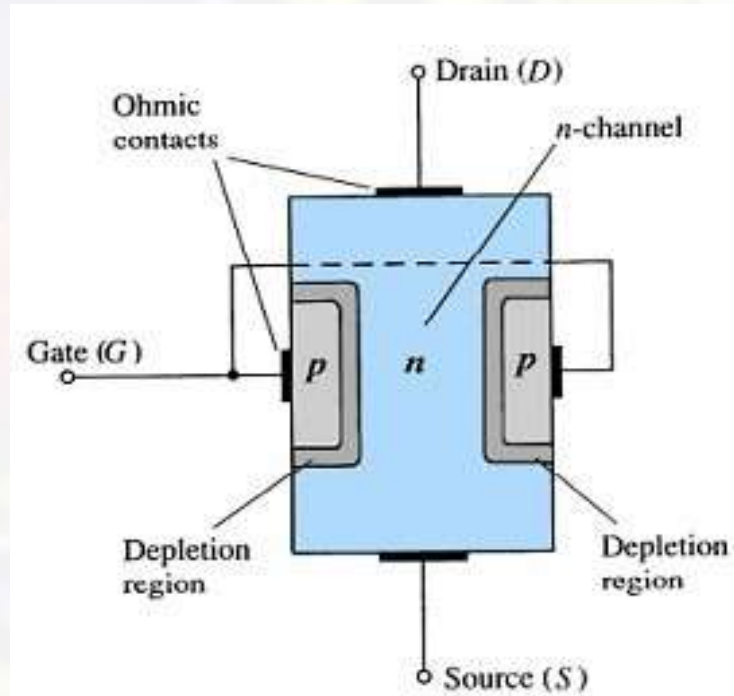



P-channel JFET

- P channel JFET:
 - Major structure is p-type material (channel) between embedded n-type material to form 2 p-n junction.
 - Current flow : from Source (S) to Drain (D)
 - Holes injected to Source (S) through p type channel and flowed to Drain (D)



P-channel JFET..

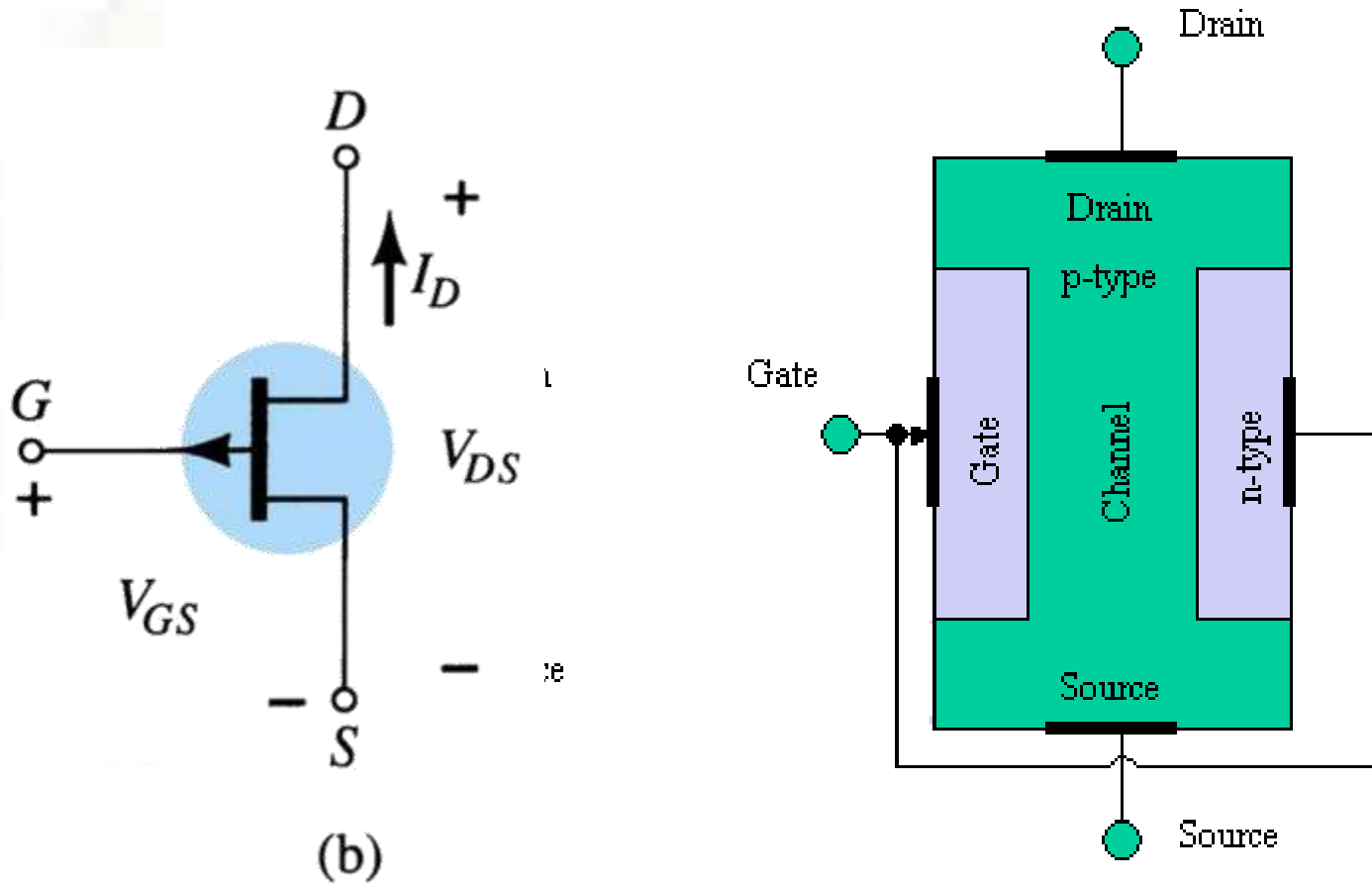



Water analogy for the JFET control mechanism

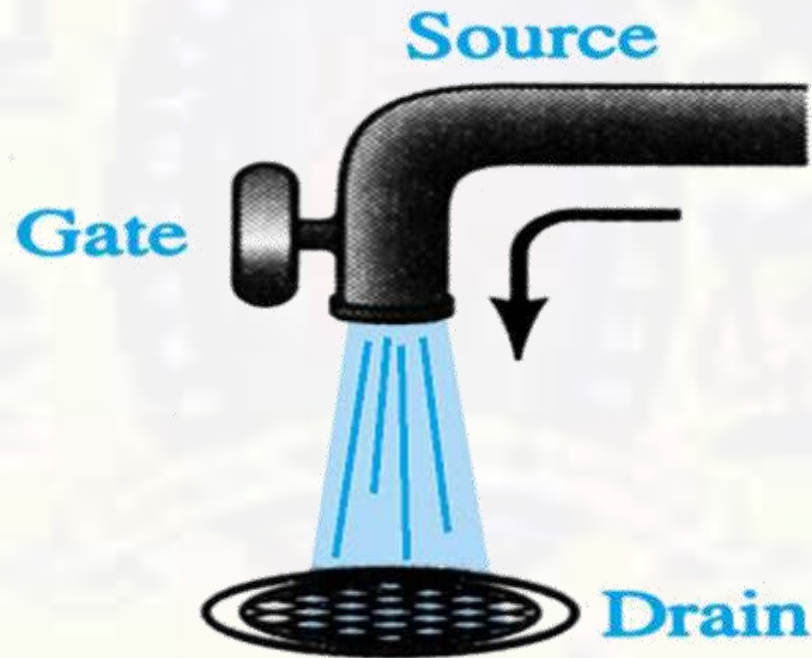



■ P-type (gate)

■ N-type (channel)

■ Depletion zone

© J. C. G. Lesurf Univ. St. Andrews

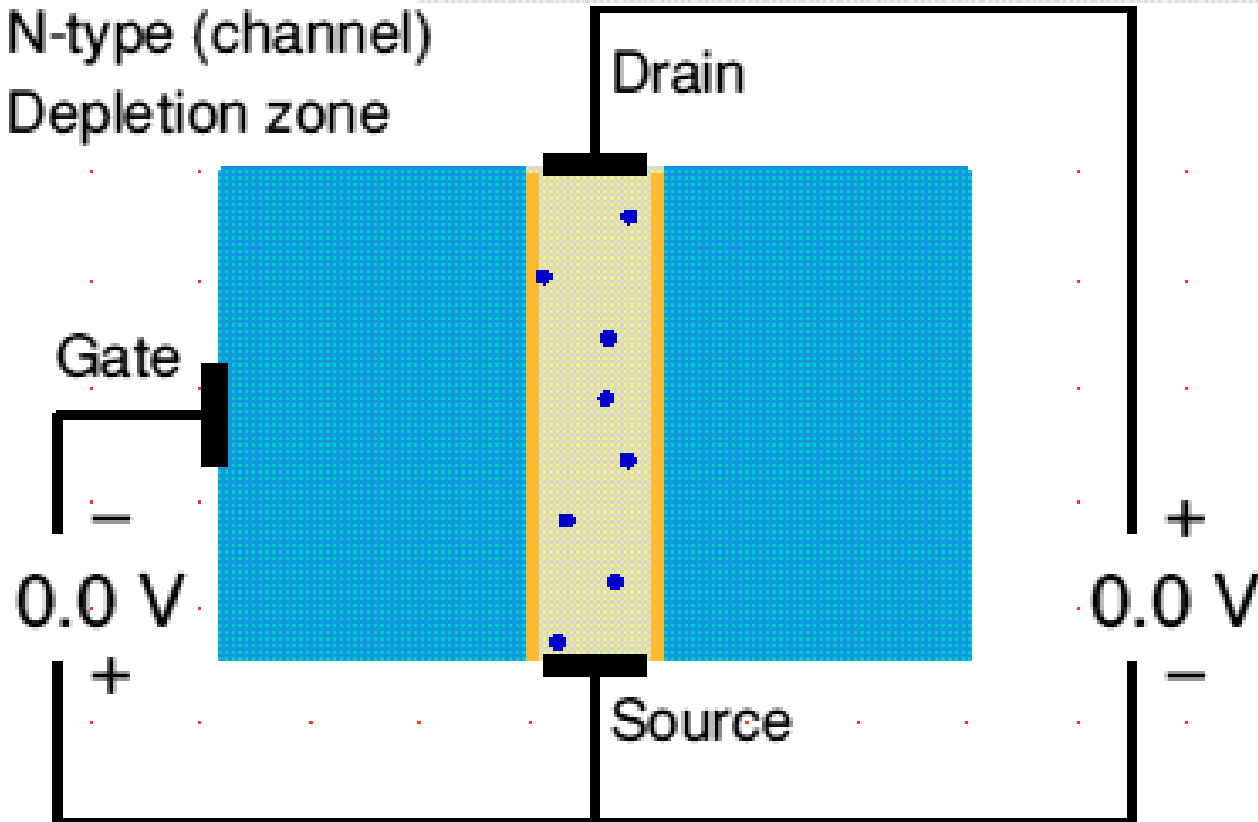



JFET Operating Characteristics

There are three basic operating conditions for a JFET:

- $V_{GS} = 0$, V_{DS} increasing to some positive value
- $V_{GS} < 0$, V_{DS} at some positive value
- Voltage-controlled resistor



JFET Characteristic for $V_{GS} = 0$ V and $0 < V_{DS} < |V_p|$

- To start, suppose $V_{GS} = 0$
- Then, when V_{DS} is increased, I_D increases. Therefore, I_D is proportional to V_{DS} for small values of V_{DS}
- For larger value of V_{DS} , as V_{DS} increases, the depletion layer become wider, causing the resistance of channel increases.
- After the pinch-off voltage (V_p) is reached, the I_D becomes nearly constant (called as $I_{D\text{ maximum}}$, I_{DSS} -Drain to Source current with Gate Shorted)



JFET for V_{GS}

$= 0 \text{ V}$ and $0 < V_{DS} < |V_p|$

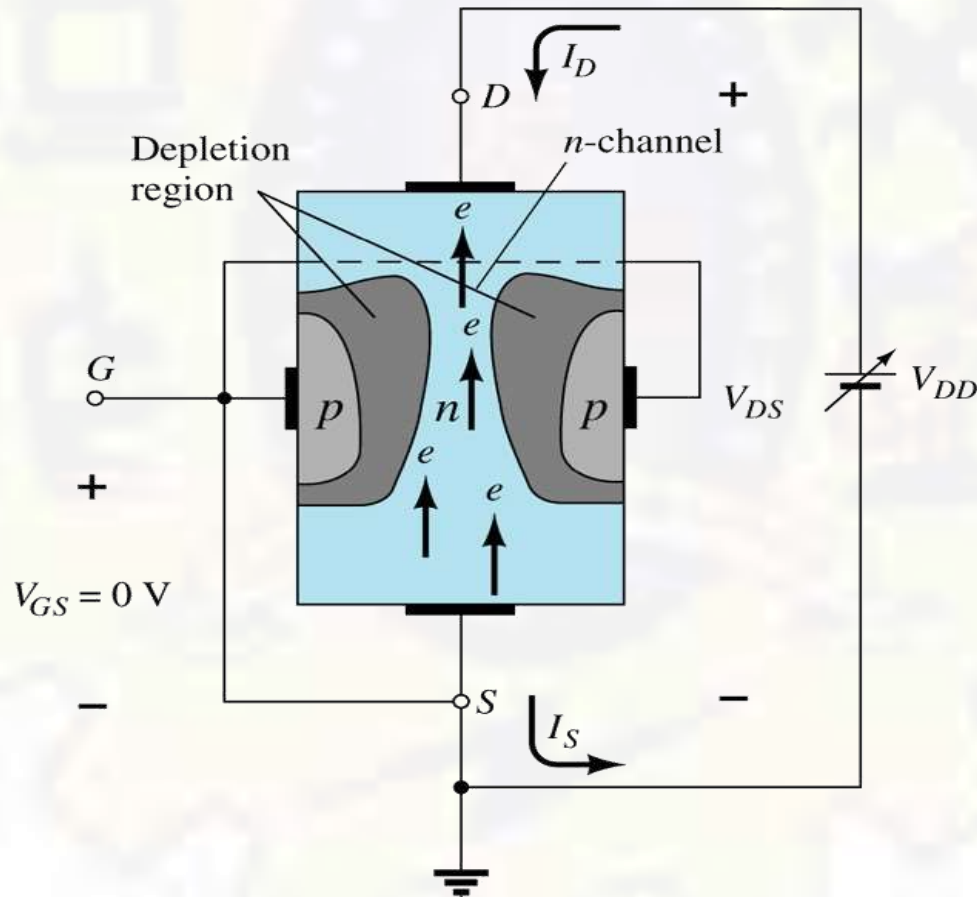

Channel becomes narrower as V_{DS} is increased



Pinch-off ($V_{GS} = 0 \text{ V}, V_{DS} = V_P$).

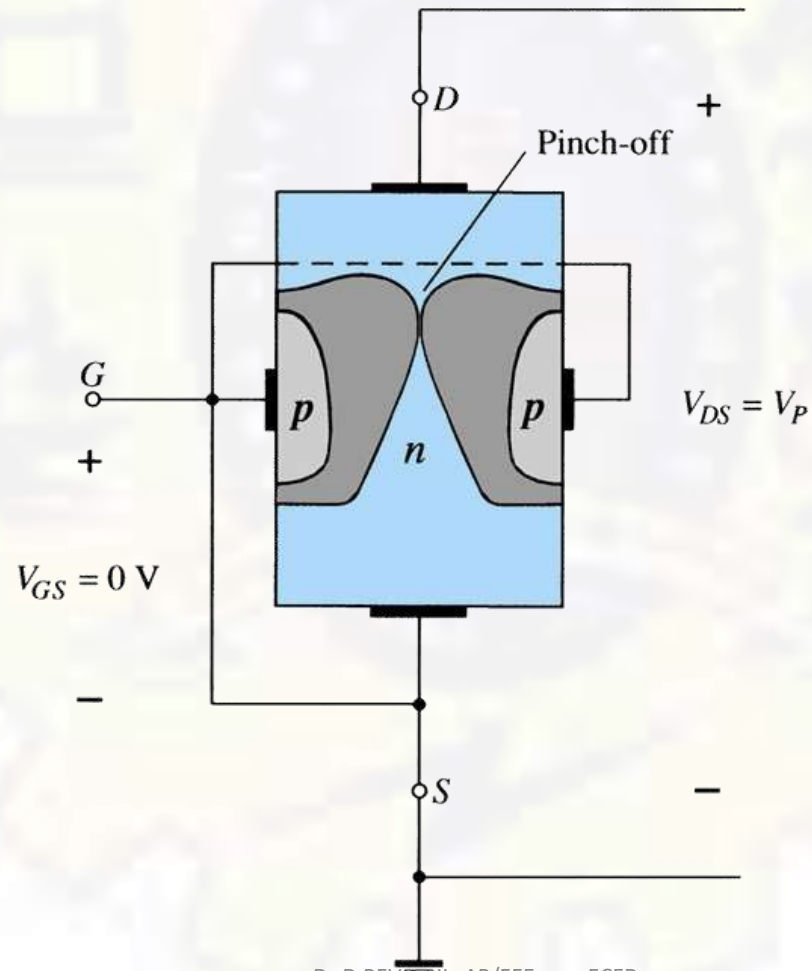



I_D versus V_{DS}

for $V_{GS} = 0$ V and $0 < V_{DS} < |V_p|$

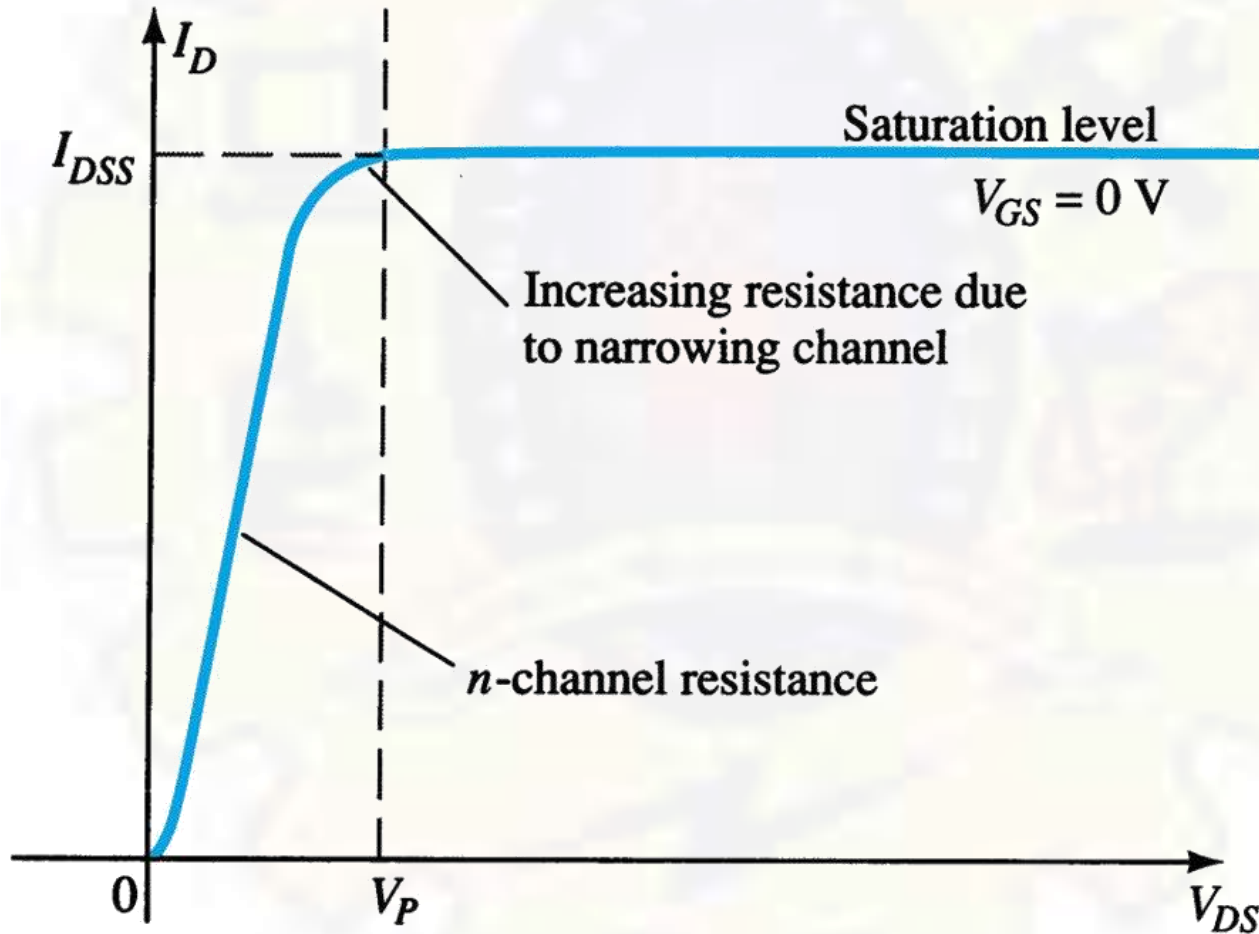

JFET Characteristic Curve



$V_{GS} < 0$, V_{DS} at some positive value

JFET Characteristic Curve..

- For negative values of V_{GS} , the gate-to-channel junction is reverse biased even with $V_{DS}=0$
- Thus, the initial channel resistance of channel is higher.
- The resistance value is under the control of V_{GS}
- If $V_{GS} = \text{pinch-off voltage}(V_P)$
The device is in **cutoff** ($V_{GS} = V_{GS(\text{off})} = V_P$)
- The region where I_D constant – The **saturation/pinch-off region**
- The region where I_D depends on V_{DS} is called the **linear/ohmic region**



$V_{GS} < 0$, V_{DS} at some positive value

JFET Operating Characteristics

As V_{GS} becomes more negative:

- The JFET experiences pinch-off at a lower voltage (V_p).
- I_D decreases ($I_D < I_{DSS}$) even though V_{DS} is increased.
- Eventually I_D reaches 0 A. V_{GS} at this point is called V_p or $V_{GS(off)}$.

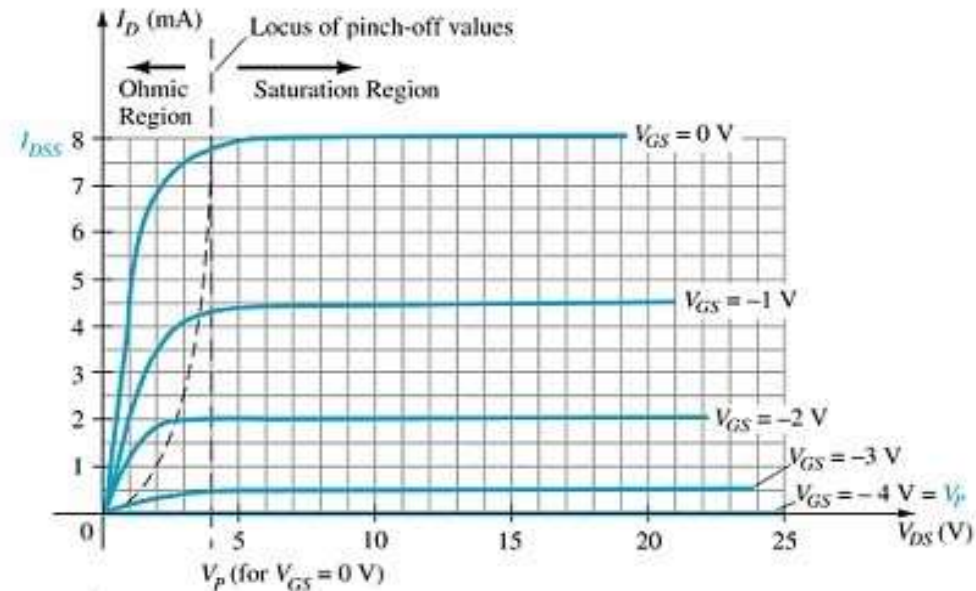

Also note that at high levels of V_{DS} the JFET reaches a breakdown situation. I_D increases uncontrollably if $V_{DS} > V_{DSmax}$.



p -Channel JFET characteristics with

$I_{DSS} = 6 \text{ mA}$ and

$V_P = +6 \text{ V}$.

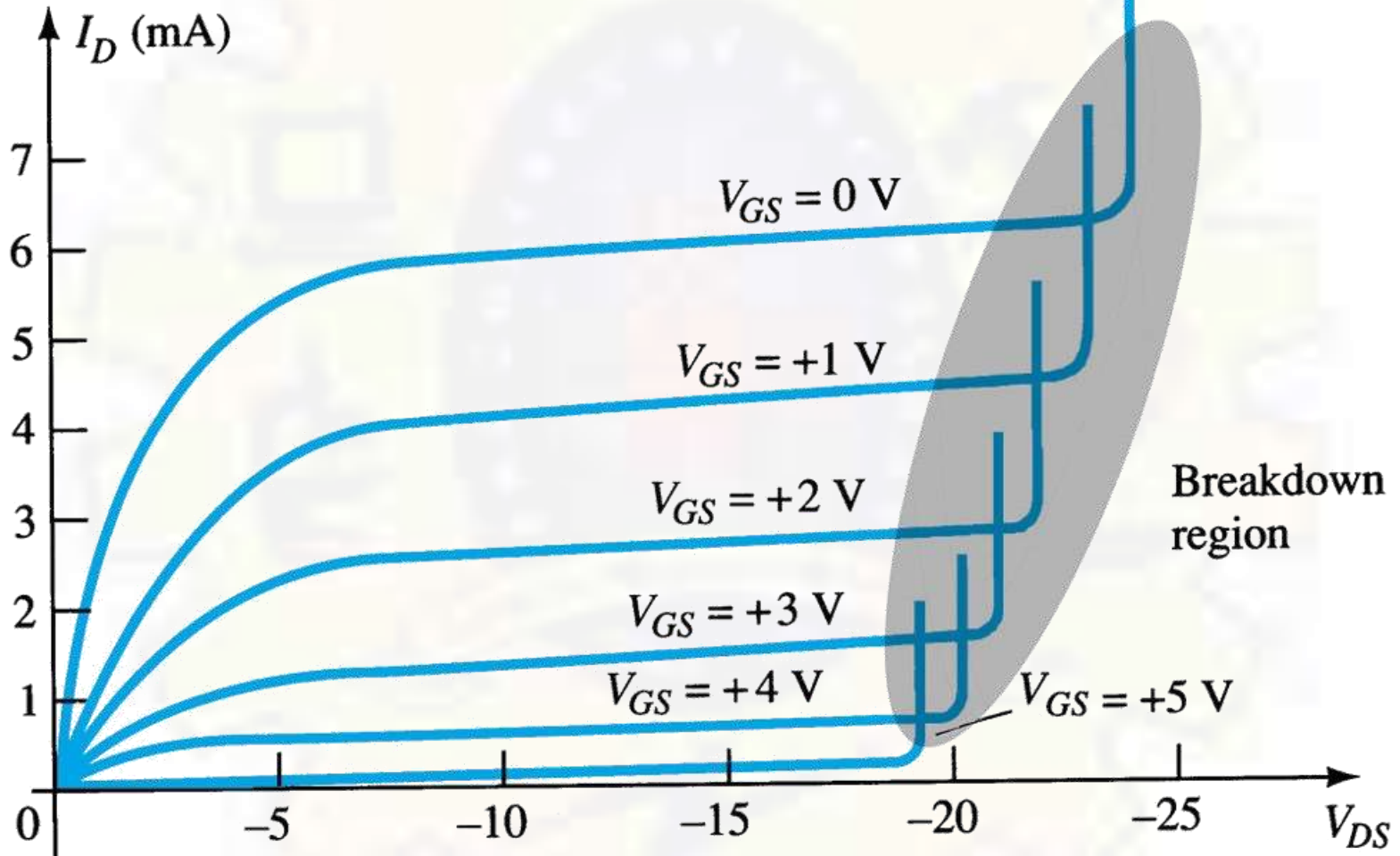



Transfer Characteristics

The input-output transfer characteristic of the JFET is not as straight forward as it is for the BJT. In BJT:

$$I_C = \beta I_B$$

which β is defined as the relationship between I_B (input current) and I_C (output current).