

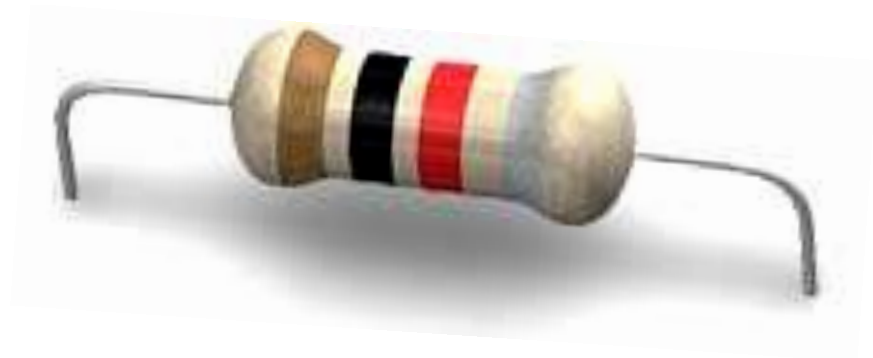

Series, Parallel, and Series-Parallel Circuits

UNIT I





Review:

Basic Elements of a Circuit

- An electric circuit provides a complete path for current to flow
- A basic circuit must include:
 - Power Source (battery)
 - Complete Path (wires)
 - Load (resistor, light, motor, etc.)
- Many circuits also include:
 - Control Devices (switch, etc.)
 - Protective Devices (fuse, circuit breaker, etc)

What components does the circuit below include?

Answer: Load, Path, Source, & Control

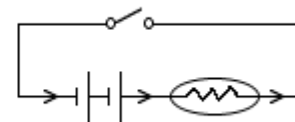
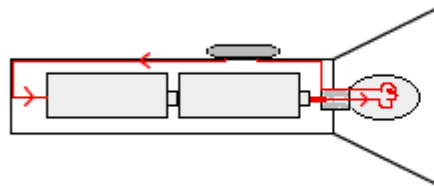



Types of Circuits

- Circuits with multiple loads can be placed into one of three categories: Series, Parallel, & Series-Parallel
- These are based on paths of current flow through the circuit



Series Circuits

- Only allow current to flow through one path from – to + through the loads
- Current only has one way to go from one side of the power source to the other

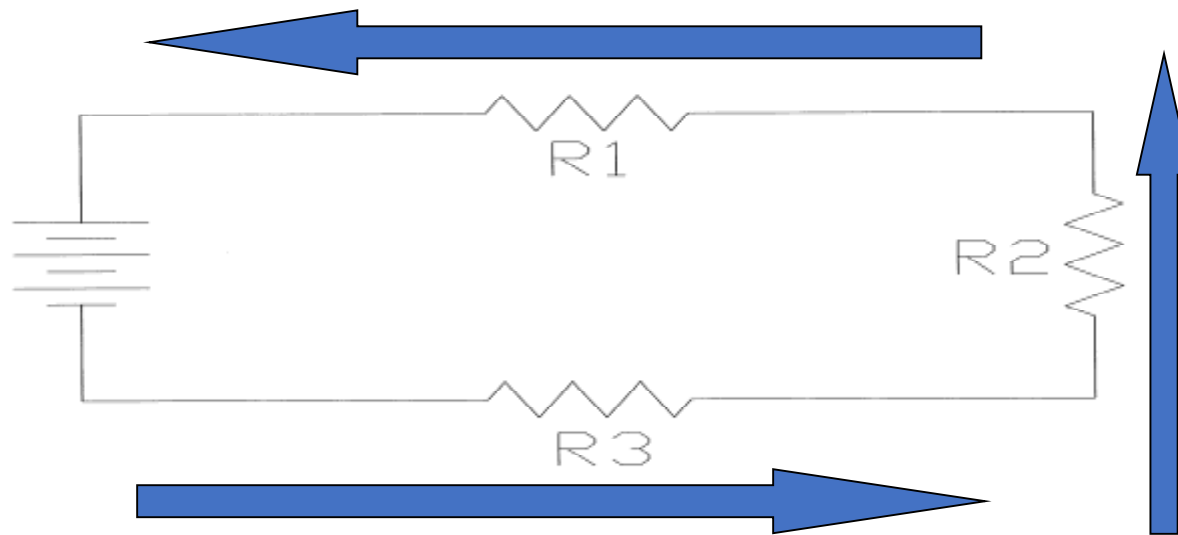



Parallel Circuits

- Allows current to take Multiple Paths from – to + through the loads.
- Current can follow different routes from the source, through the loads, and back to the source

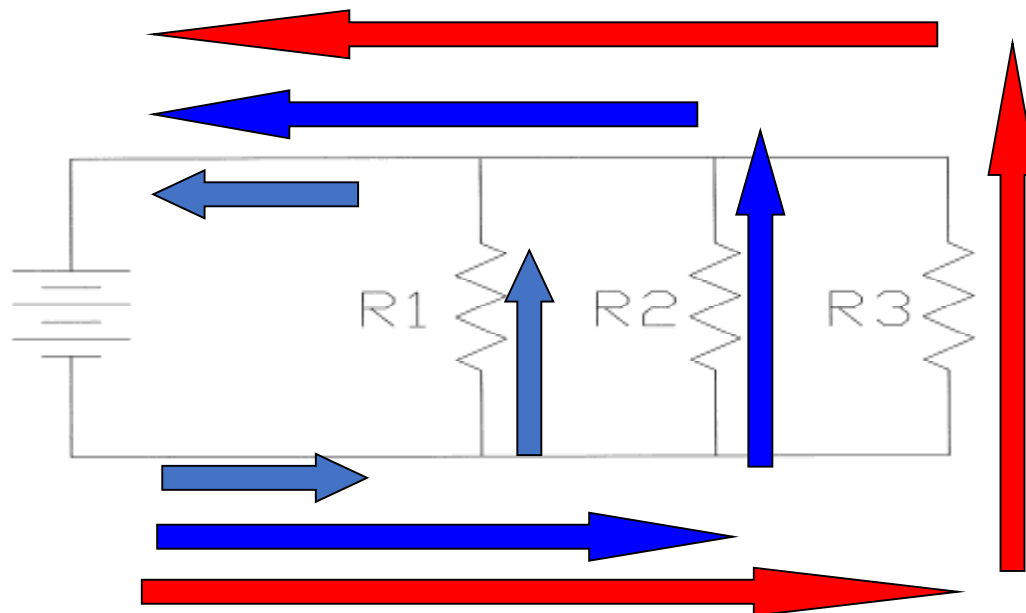

Series-Parallel Circuits

- Contains areas of both Series & Parallel circuits
- Some sections allow multiple paths for current flow
- Other areas only allow one path for current flow
- Must have at least three loads

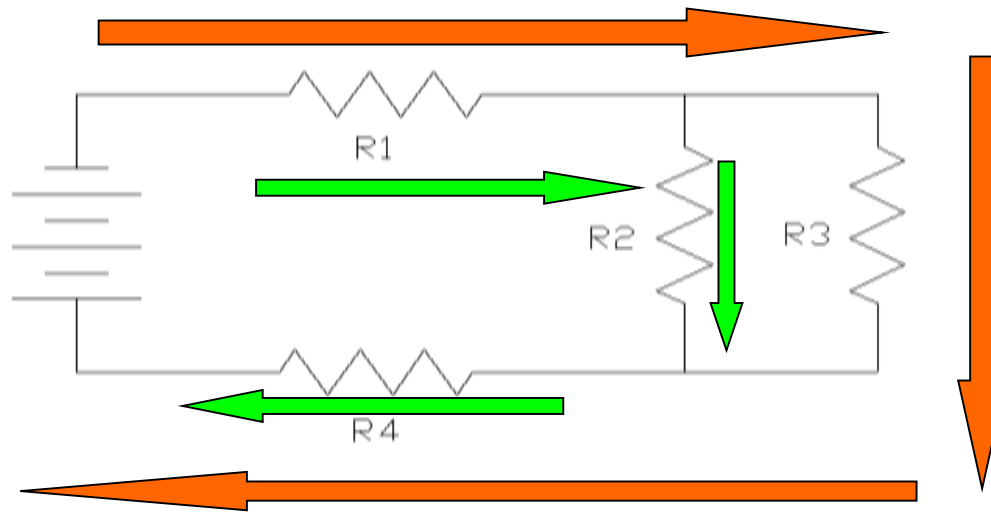

Resistance Calculations

- Because some circuits allow current to follow multiple paths, current divides among these paths
- This reduces the total current of these sections
- Therefore, different resistance formulas must be used for different circuits

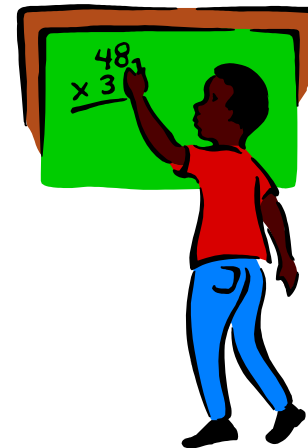

Series Circuit Calculations

- Only allow current to follow one path
- Total resistance is equal to the sum of all the individual resistances
- Formula $R_t = R_1 + R_2 + R_3...$

$$R_1 = 10\Omega$$

$$R_2 = 20\Omega$$

$$R_3 = 30\Omega$$

$$R_t = R_1 + R_2 + R_3$$

$$R_t = 10\Omega + 20\Omega + 30\Omega$$

$$R_t = 60\Omega$$

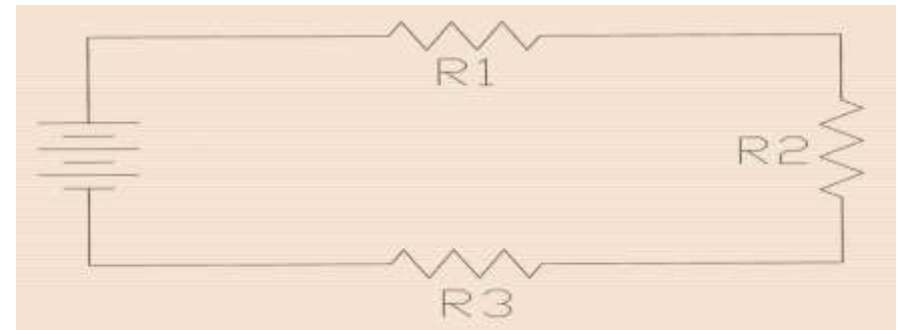



Series-Parallel Circuit Calculations

- Contain series & parallel elements
- Must use series & parallel formulas
- First determine Parallel R-value, then add to series sections

$$\mathbf{R1} = 10\Omega \quad \mathbf{R2} = 10\Omega \quad \mathbf{R3} = 10\Omega \quad \mathbf{R4} = 10\Omega$$

$$Rt = (R1 \times R2) / (R1 + R2)$$

$$Rt = (10 \times 10) / (10 + 10)$$

$$Rt = 100 / 20$$

$$Rt = 5\Omega$$

$$Rt = R1 + R2 + R3$$

$$Rt = 10\Omega + 5\Omega + 10\Omega$$

$$\mathbf{Rt = 25\Omega}$$

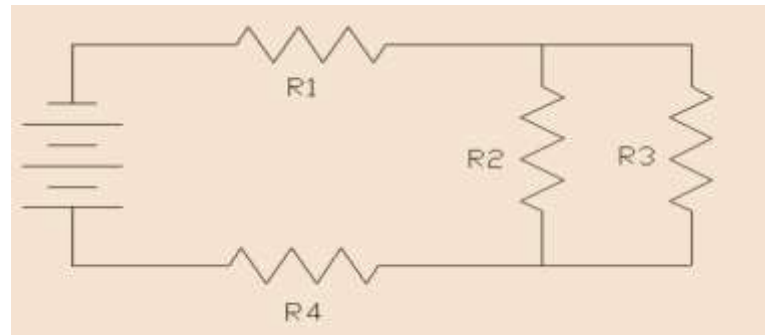



Parallel Circuit Calculations

- Allow current to follow Multiple Paths
- Current divides among paths
- Total resistance is always less than smallest resistor
- Resistance Formula: $R_t = 1 / [(1/R_1) + (1/R_2) + (1/R_3) \dots]$
 - This is Known as the Reciprocal Formula

$$R_1 = 10\Omega \quad R_2 = 20\Omega \quad R_3 = 30\Omega$$

$$R_t = 1 / [(1/R_1) + (1/R_2) + (1/R_3)]$$

$$R_t = 1 / [(1/10) + (1/20) + (1/30)]$$

$$R_t = 1 / [.1 + .05 + .033]$$

$$R_t = 1 / .183$$

$$R_t = 5.45 \Omega$$

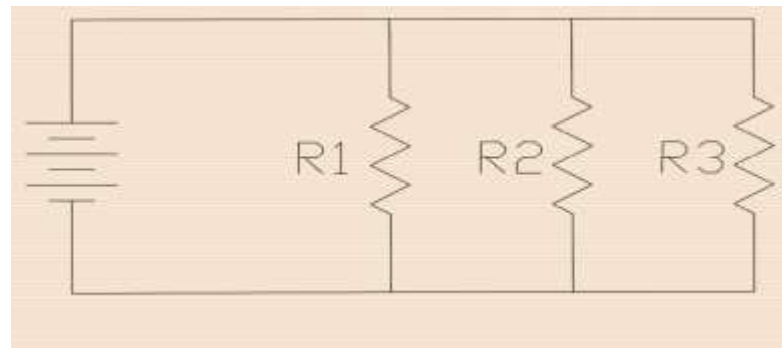



Parallel Circuit Calculations (Only Two Resistors)

- If only Two resistors are in parallel, then another formula can also be used to calculate total resistance
- This formula is: $R_t = (R_1 \times R_2) / (R_1 + R_2)$
- Total resistance is always less than smallest resistor

$$\mathbf{R_1 = 20\Omega \quad R_2 = 20\Omega}$$

$$R_t = (R_1 \times R_2) / (R_1 + R_2)$$

$$R_t = (20 \times 20) / (20 + 20)$$

$$R_t = 400 / 40$$

$$\mathbf{R_t = 10\Omega}$$

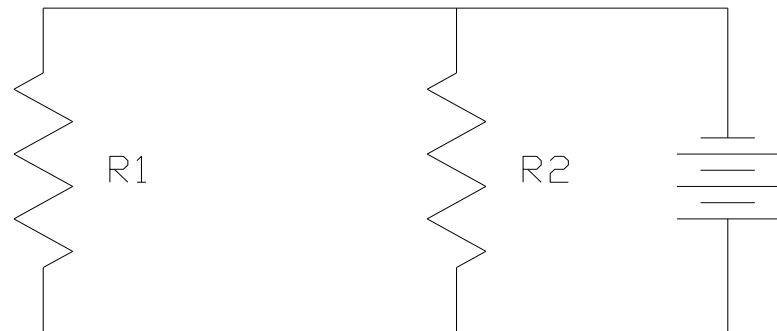



Parallel Circuit Calculations (All Resistors Are the Same)

- If all of the resistors in the circuit are equal, then this formula may be used:
 - $R_t = R / N$ (N = Number of resistors/ loads)
- Total resistance is always less than smallest resistor

$$R_1 = 30\Omega \quad R_2 = 30\Omega \quad R_3 = 30\Omega$$

$$R_t = R / N$$

$$R_t = 30 / 3$$

$$R_t = 10\Omega$$

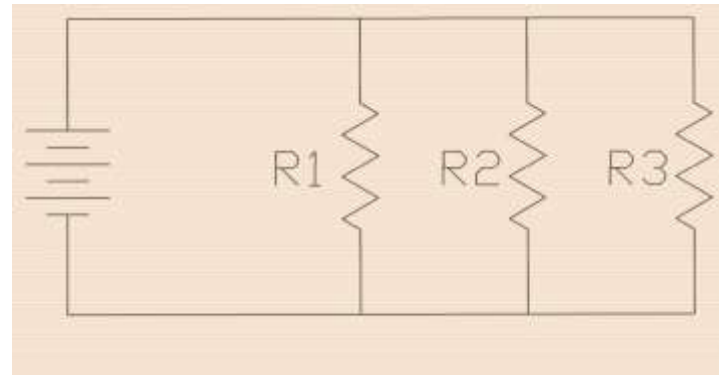



Guided Practice #1

- What kind of circuit is it?

Series Circuit

- What Formula can be used?

$$R_t = R_1 + R_2 + R_3$$

- What is the total resistance?

$$R_1 = 30\Omega$$

$$R_2 = 50\Omega$$

$$R_3 = 70\Omega$$

$$R_t = R_1 + R_2 + R_3$$

$$R_t = 30\Omega + 50\Omega + 70\Omega$$

$$\mathbf{R_t = 150\Omega}$$

