

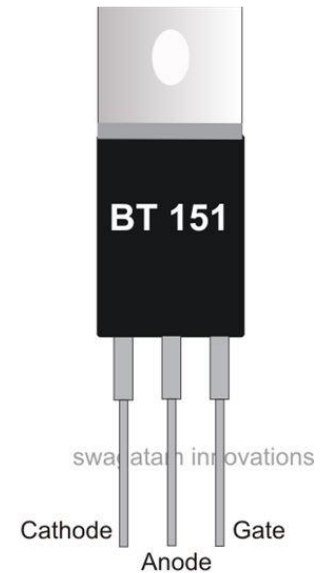

UNIT IV

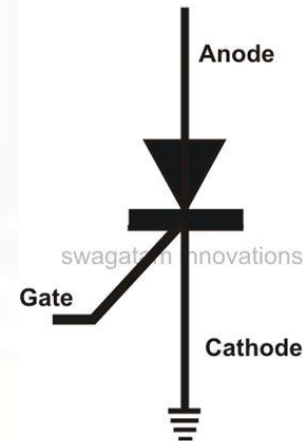

SILICON CONTROLLED RECTIFIER

Introduction

- SCR is most popular of thyristor family due to its *Fast switching action , small size and high voltage and current ratings.*
- It is commonly used in power electronic applications.
- SCR has 3 terminals (gate provides control)
- SCR is turned on by applying +ve gate signal when anode is +ve with respect to cathode.
- SCR is turned off by interrupting anode current.

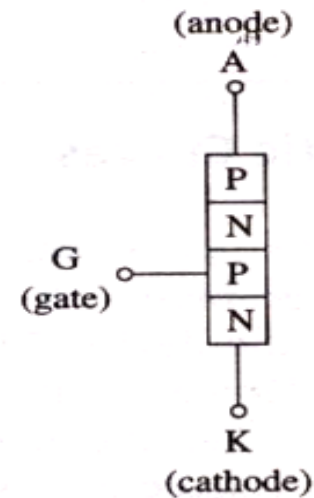

PNPN structure

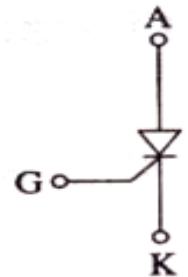

Symbol

What is a silicon control rectifier?

A Silicon Controlled Rectifier (SCR) is a four layer solid state device that controls current flow. SCR is a three terminal device.

The terminals are:

- Gate (G)
- Anode (A)
- Cathode (K)

Two main uses of SCR are:

- Switching
- Amplification

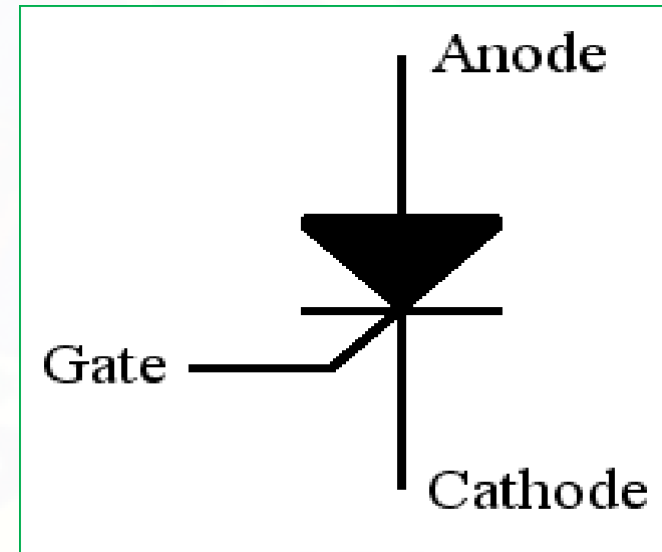

Basic SCR

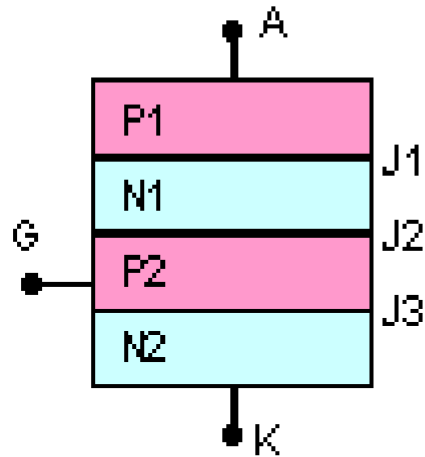

a. Simplified Construction

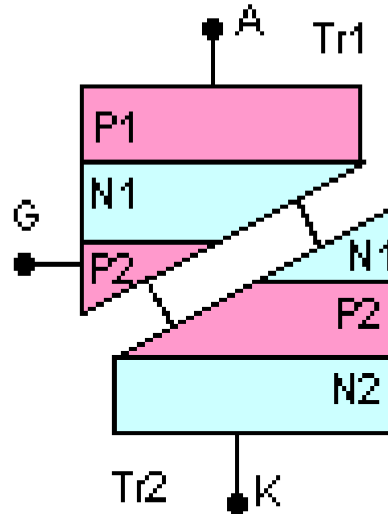

b. How we get the two transistor model

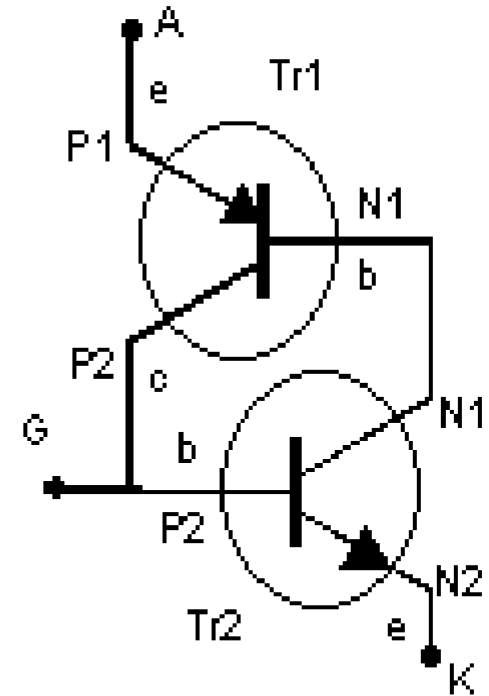

c. The Two Transistor Model

How does SCR work?

- Load is connected in series with anode.
- The anode is always kept at a higher potential than the cathode.

The working of SCR is to be studied under two different conditions:

1. When Gate (G) is open
2. When Gate (G) is positive with respect to Cathode (K)

-When Gate is Open

no voltage to the gate. J_2 is reverse biased while J_1 & J_3 are forward biased. reverse bias, no current will flow through the device \Rightarrow SCR is cut-off.

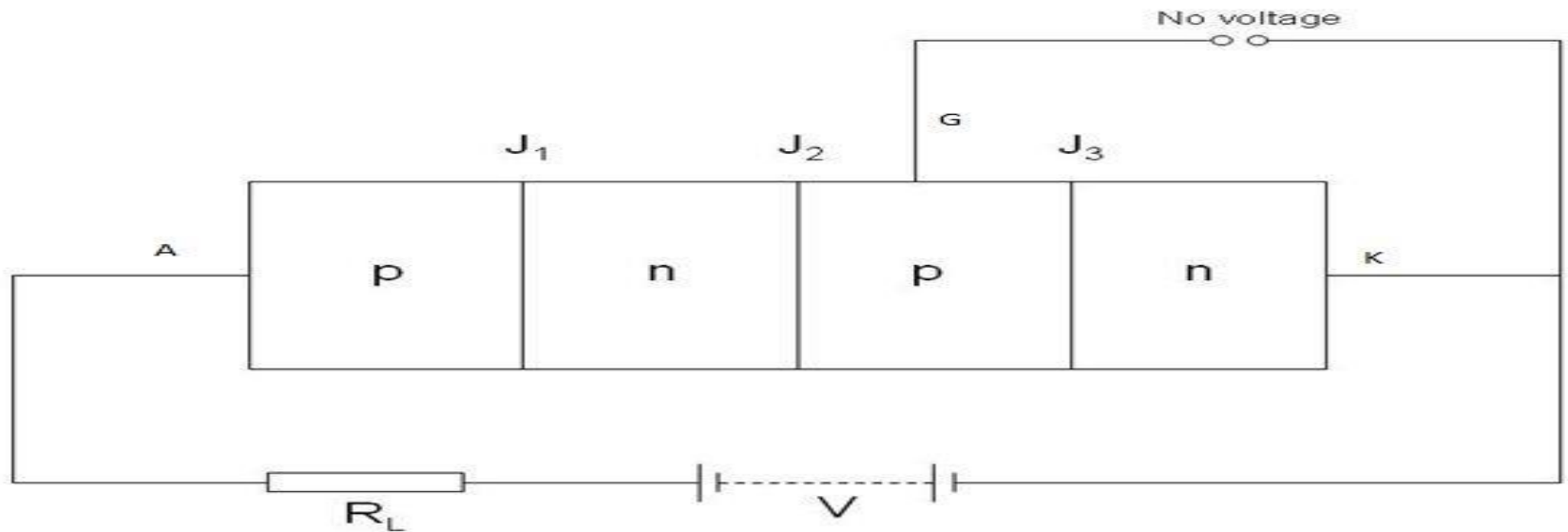

Fig: SCR with gate open

When Gate is positive with respect to cathode

- J3 is forward biased, J2 is reverse biased.
- Electrons from n-type material start moving across J3 towards left
- Similarly, holes move from p-type material towards the right.
- Eventually, the electrons that moved across J3 are now attracted across J2. This initiates the Gate current and the J2 is now conducting .

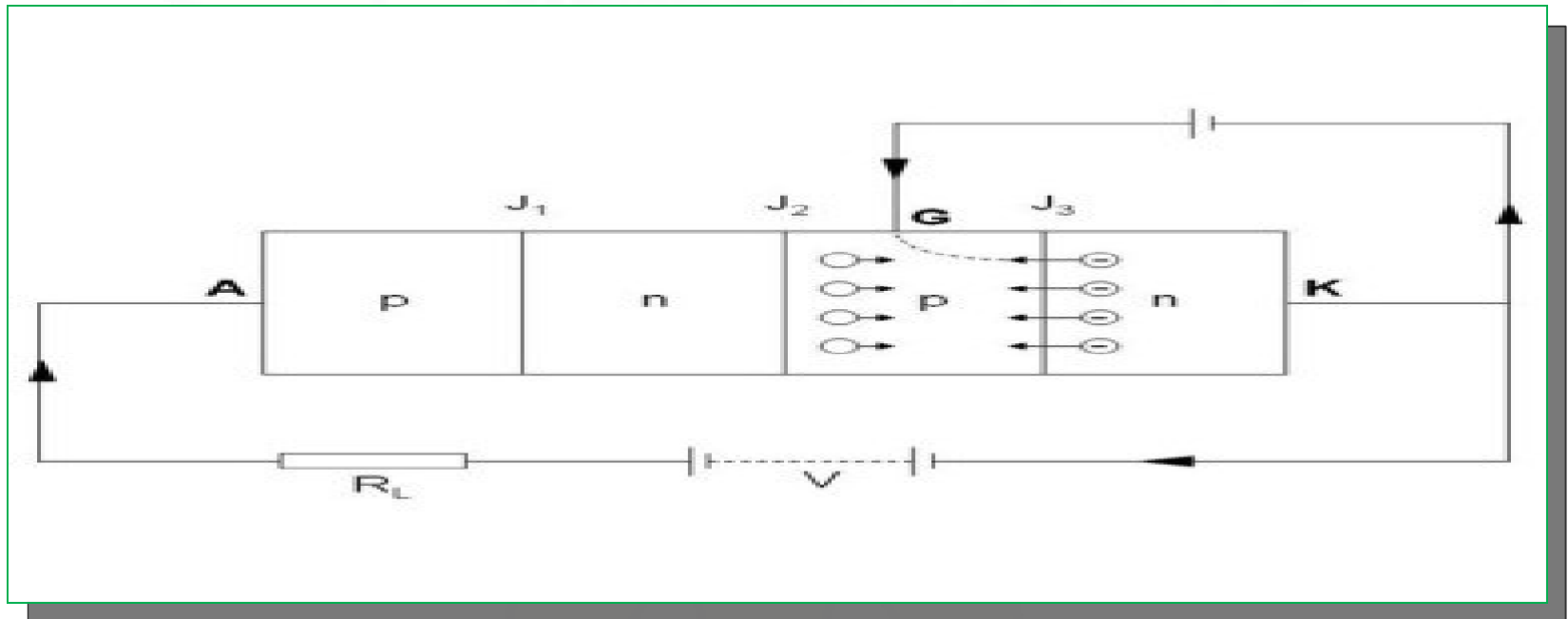
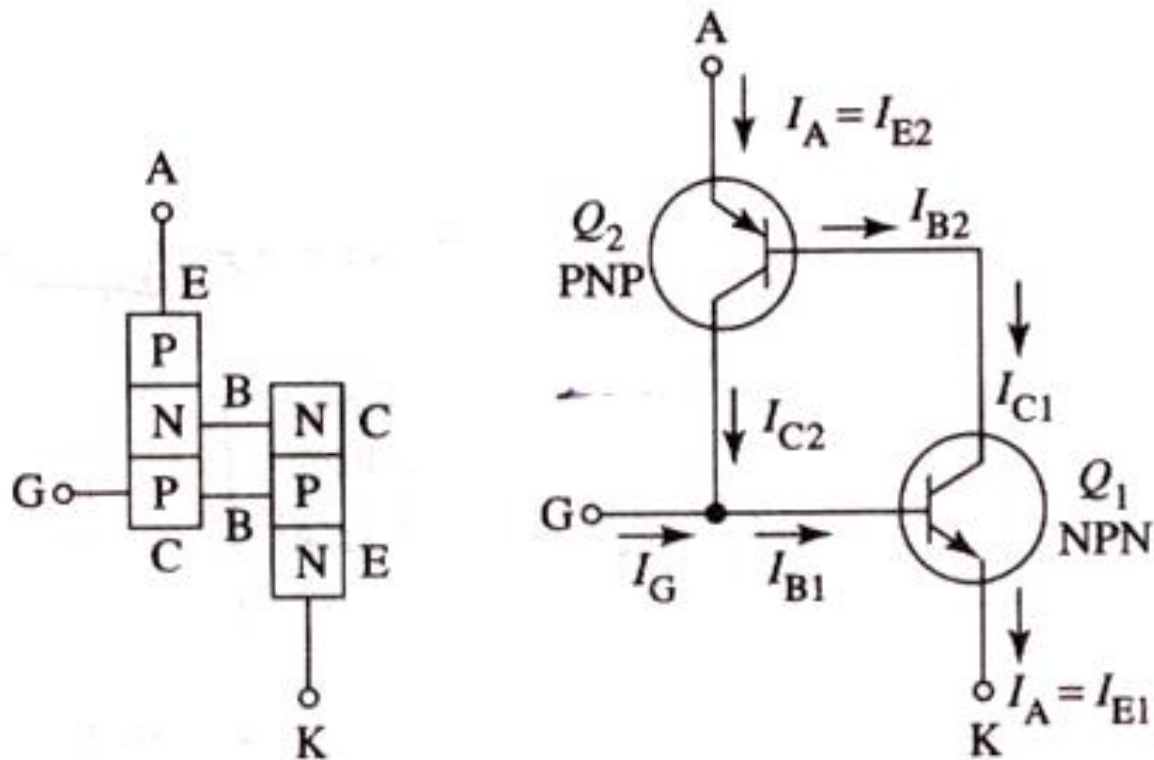

Fig: applying gate voltage

Two Transistor Model Of SCR



- *Gate requires small positive pulse for short duration to turn SCR on. Once the device is on, the gate signal serves no useful purpose and can be removed.*

SCR / Thyristor

- 4-layer (pnpn) device
- Anode, Cathode as for a conventional pn junction diode
- Cathode Gate brought out for controlling input

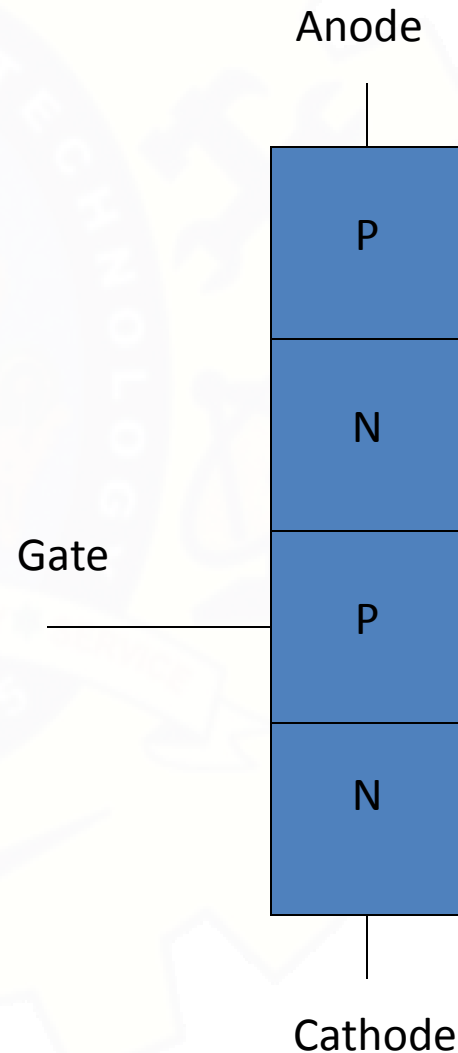

Equivalent Circuit

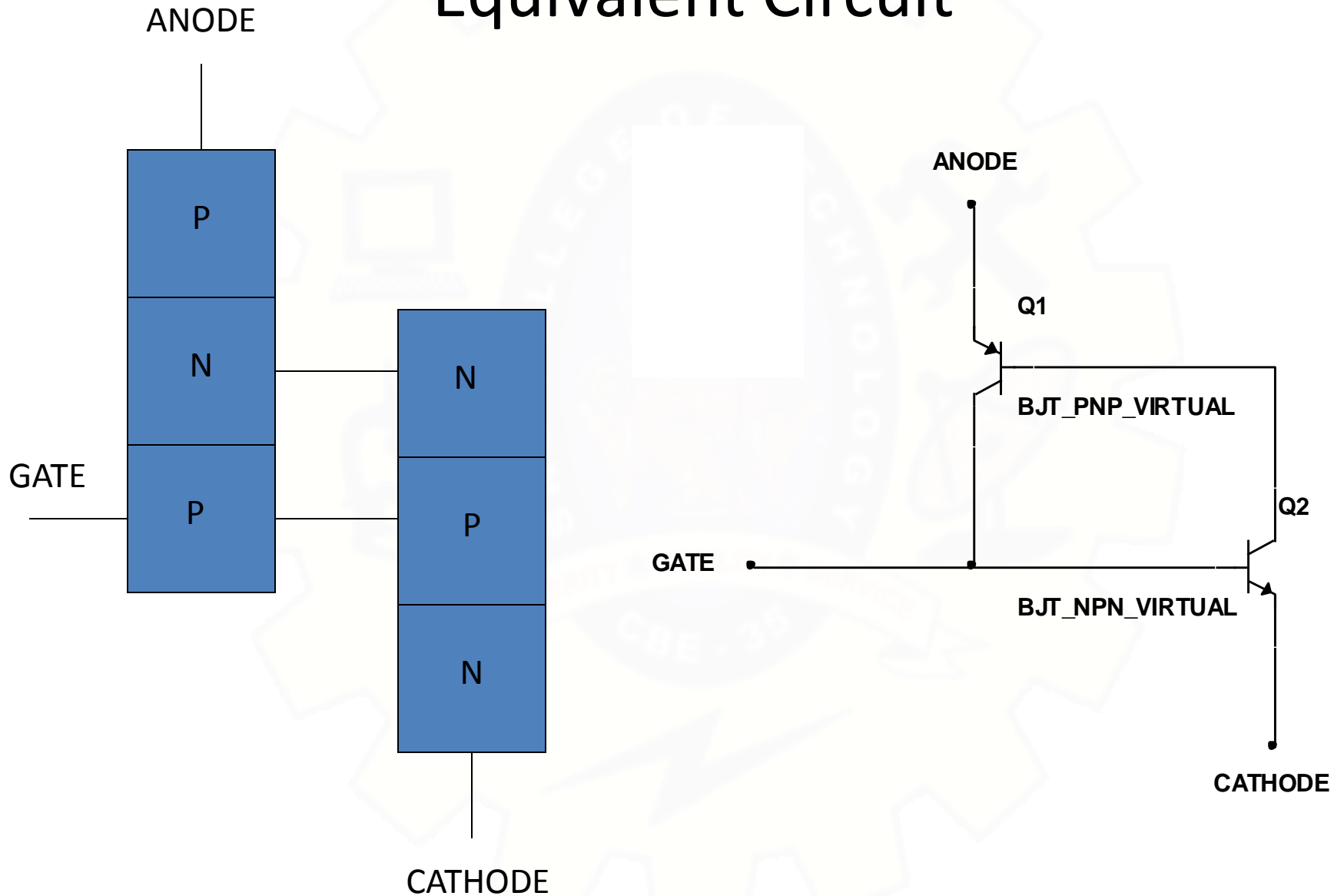

Apply Biasing

With the Gate terminal OPEN, both transistors are OFF. As the applied voltage increases, there will be a “breakdown” that causes both transistors to conduct (saturate) making $I_F > 0$ and $V_{AK} = 0$.

$$V_{\text{Breakdown}} = V_{\text{BR(F)}}$$

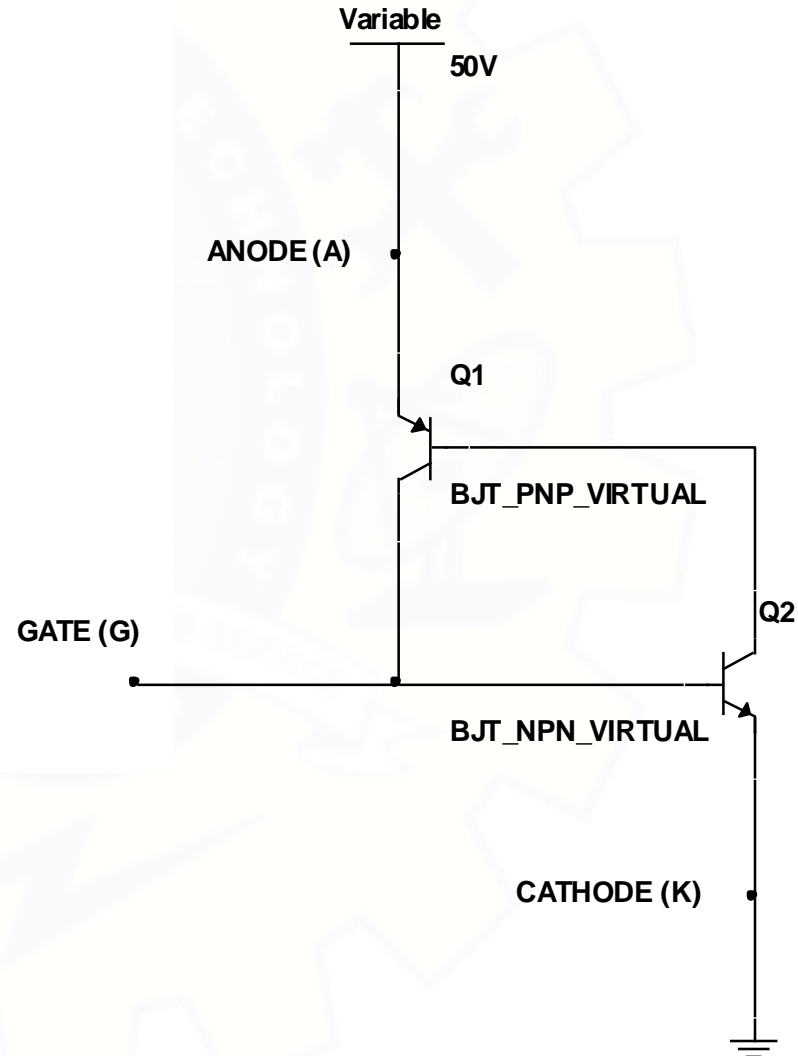

SCR Characteristic Curve

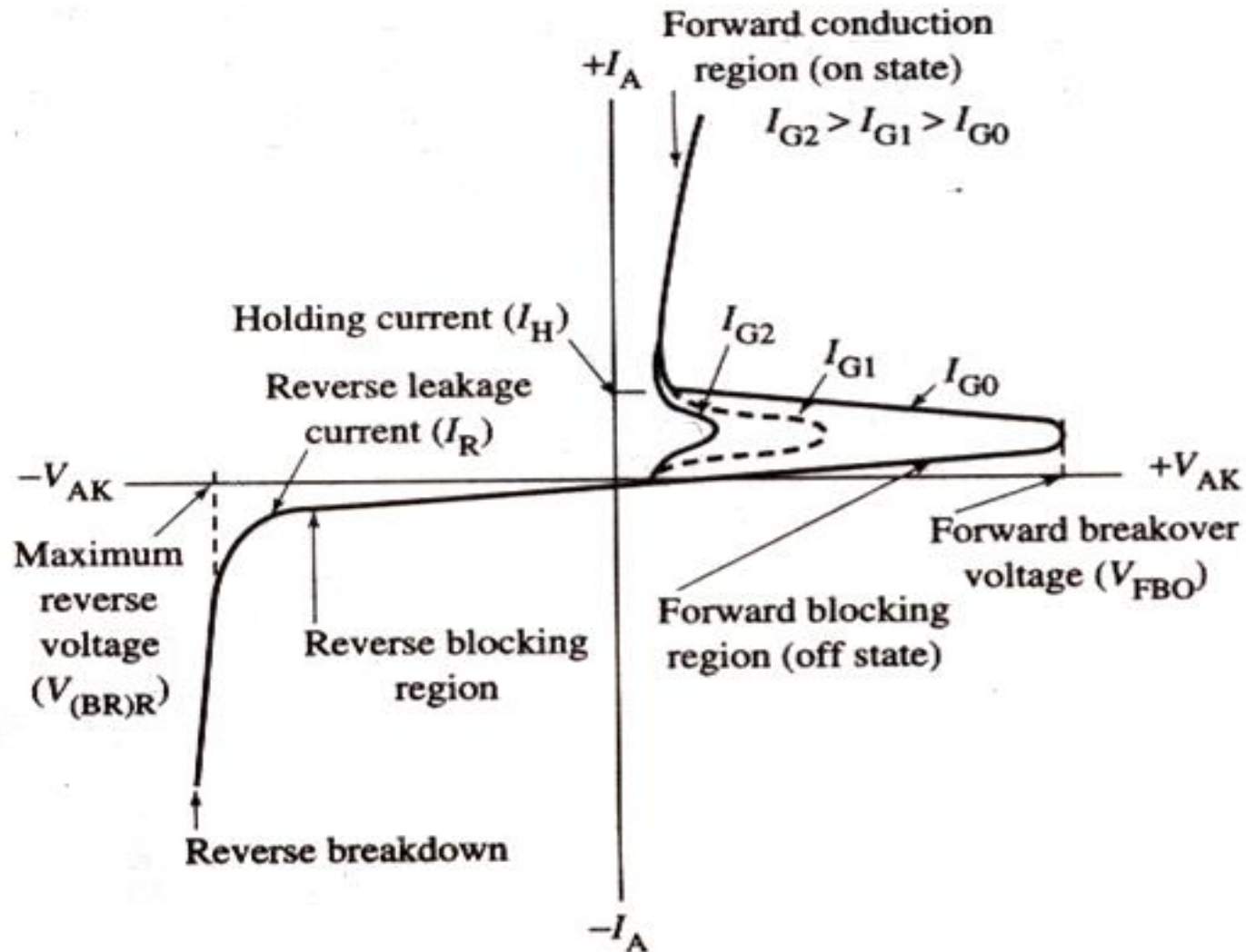

Apply a Gate Current

For $0 < V_{AK} < V_{BR(F)}$,

Turn Q_2 ON by applying a current into the Gate

This causes Q_1 to turn ON, and eventually both transistors SATURATE

$$V_{AK} = V_{CEsat} + V_{BEsat}$$

If the Gate pulse is removed, Q_1 and Q_2 still stay ON!

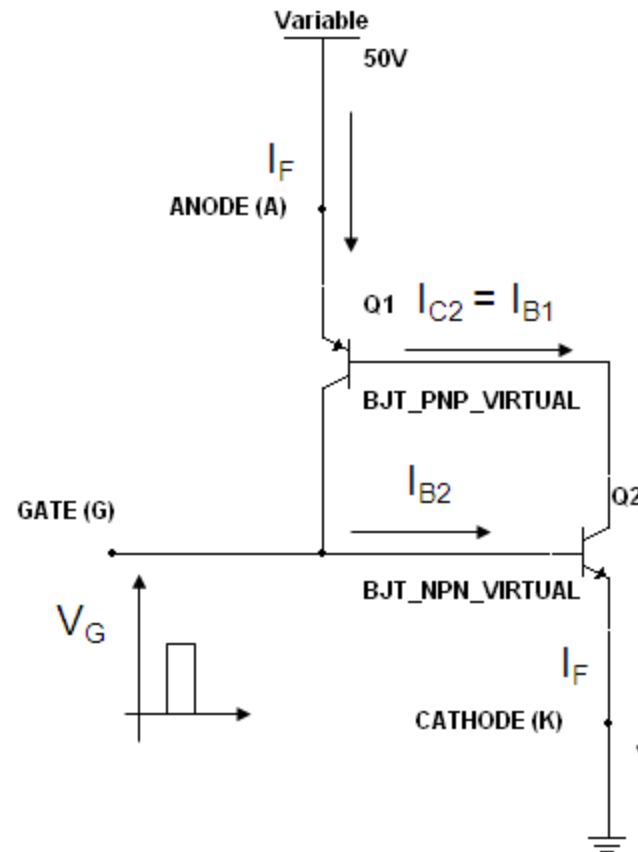

The SCR has three basic states:

1. Forward blocking mode or off state: In this mode or state the SCR operation is such that it blocks forward current conduction that would normally be carried by a forward biased diode.

2. Forward conduction mode or on state: In this mode the SCR has reached into conduction.

3. Reverse blocking mode or off state: In this mode or state the SCR blocks the current in the same way as that of a reverse biased diode.

How do turn it OFF?

- Cause the forward current to fall below the value if the “holding” current, I_H
- Reverse bias the device

Importance of SCR

- It has small size and gives trouble free service
- Reliable fast action and light weight
- no mechanical part , noiseless operation

Application for SCRs:

1. Rectification ,
2. Regulated power suppliers,
3. Static switches ,
4. Motor speed controls and,
5. Battery charger and heater controls, etc.

Conclusion

Finally , Silicon control rectifier (SCR) are widely used in many areas of electronics. SCR circuits can be used for many power applications as these electronics components are able to switch high currents very easily. In addition, these electronics components are very cheap and they are widely available.