



UPS and Battery Charger

UPS

An uninterruptible power supply (Ups) is a device that allows a computer to keep running at least a short time .when primary power source is lost .It also provides protection from power fluctuation . Thus we can say that Ups is a device that helps to provide consistent power to computer system



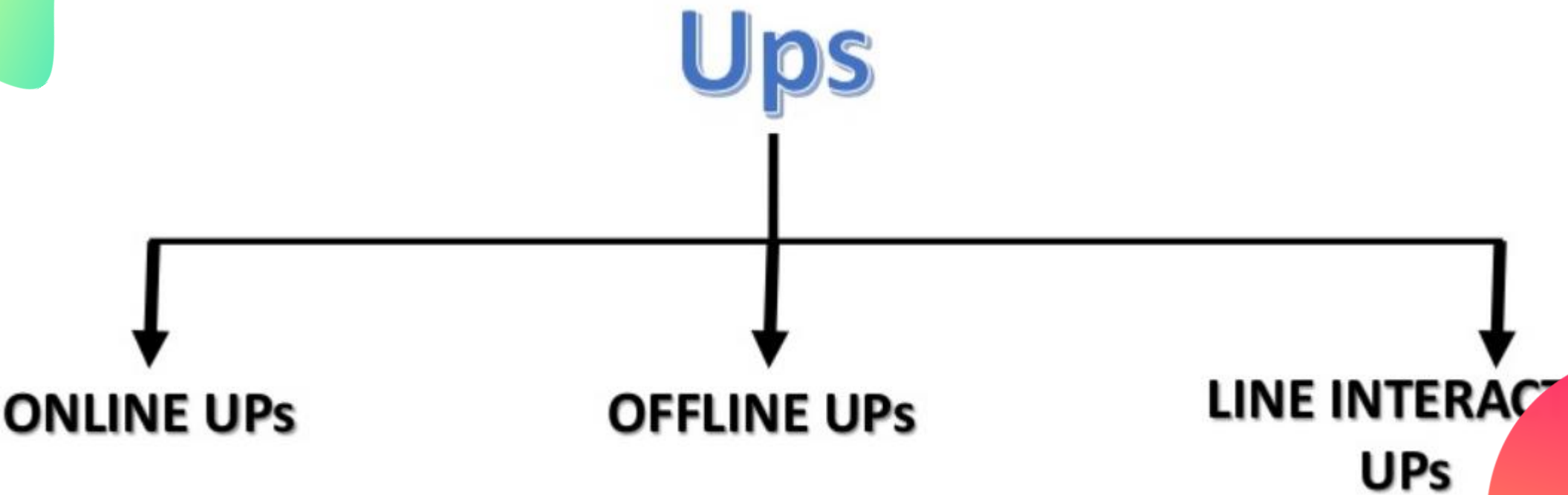

Online UPS

In this type of Ups , the system always remains on the Battery, Weather main is present or not.



Online UPS

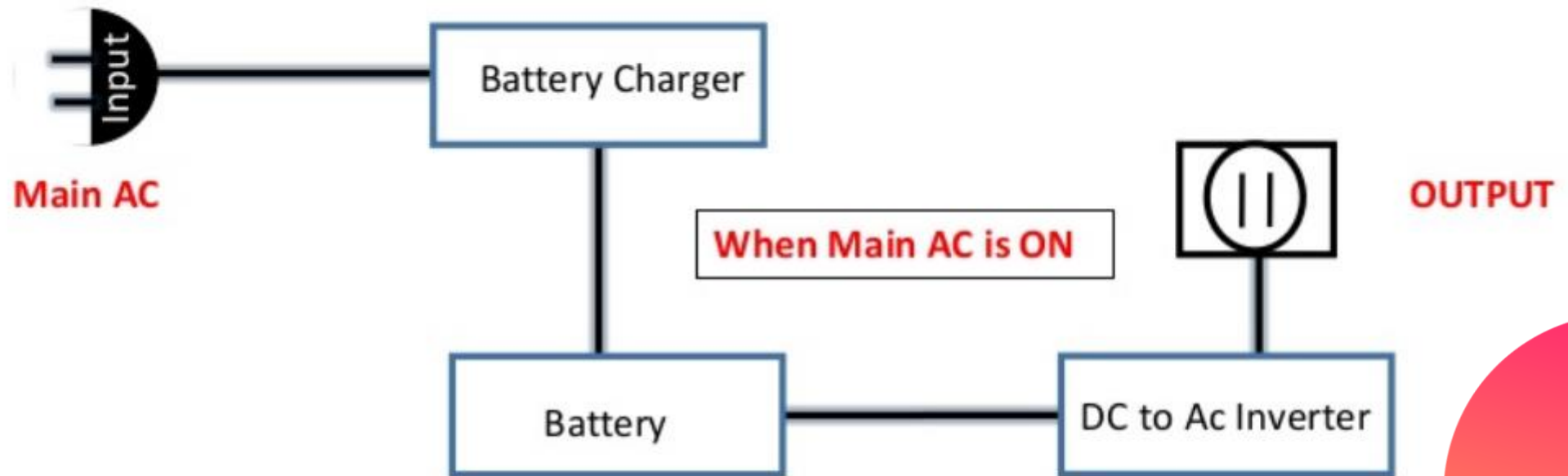

(Block Diagram Of Online Ups)

When **Main AC is Present**, it provides **power to DC Supply Of inverter Section** as well as **charges the battery** simultaneously .

Online UPS

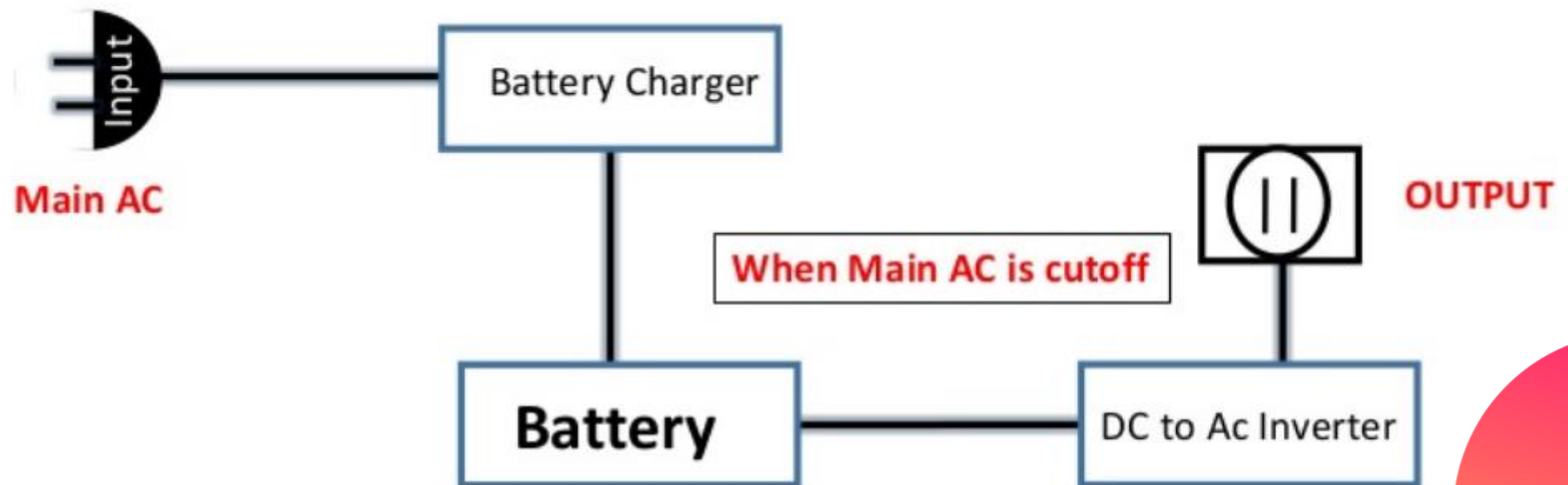

(Block Diagram Of Online Ups)

When **Main AC is not present**, it will run the **connected load till the battery** has a recommended discharge level.



Advantage of Online UPS

- When we use Online Ups there is no chance of surges , spikes , sags ,black out because the Main Ac passes through battery which gives accurate voltage supplies in any condition..
- Another advantage is that it passes charge regular through battery so there is no chance of failure of circuit like , change over timing or change over circuit.

Disadvantage of Online UPs

- In online Ups system always remain on battery, whether the Main Ac is present or not. When Main Ac is present it supplies DC to battery section for charging as well as battery also send charge to inverter section for Main Output. Due to this no battery life in Online Ups

Offline UPS

When Main AC is present ,AVR provides as output as is the Input mains.



B.CHRISTYJULIET AP/ EEE



ECED-I AIML 'A'



Offline UPS

(Block Diagram Of Offline Ups)

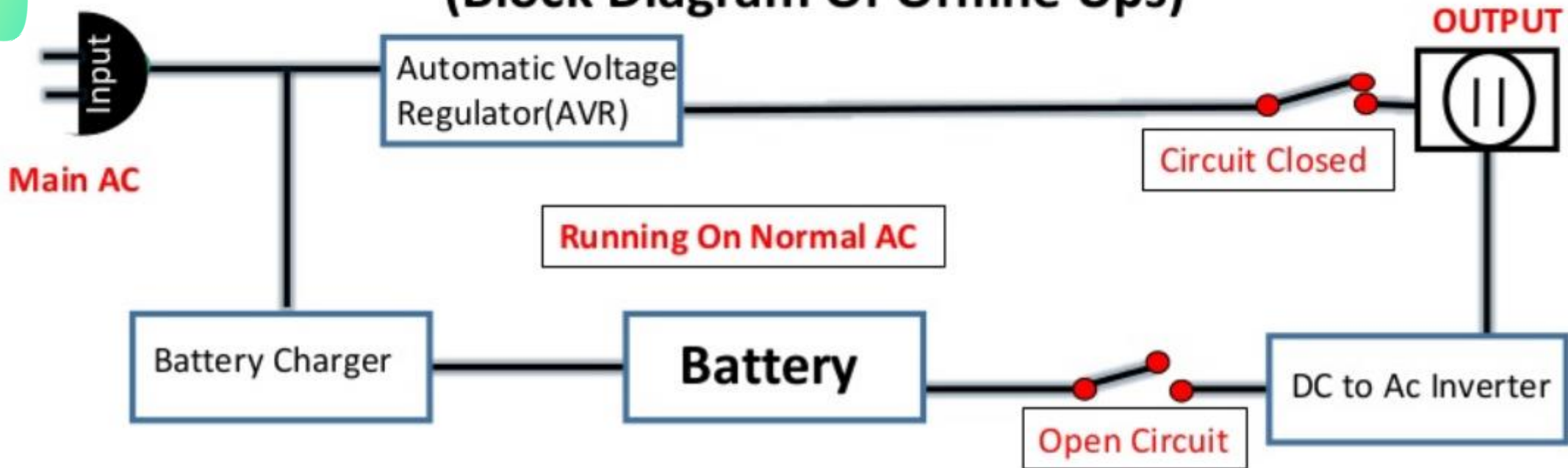

- ❖ Offline Ups use automatic voltage regulator (AVR) to regulate the output voltage close to 220V AC.
- ❖ Offline Ups are normal weight Ups and are widely used for domestic computers.



Offline UPS

(Block Diagram Of Offline Ups)

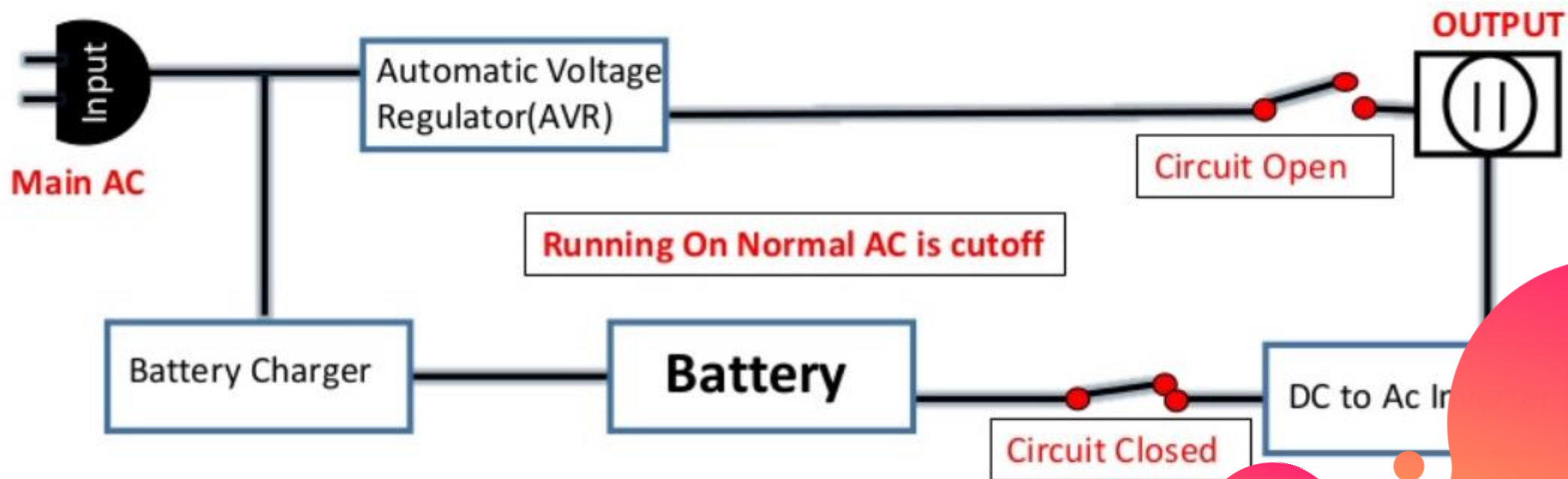

The Main is to battery changeover time or battery to mains changeover time on offline Ups is very low(3.8 milliseconds) as compared to inverter 500 milliseconds.



Advantage of Offline UPS

When Main AC is present , current passes through AVR(Automatic Voltage regulator) there is no load on battery all time therefore In offline Ups battery life is longer .



Disadvantage of Offline UPSs

- In offline UPS accuracy is less than online UPS because it passes charge through AVR therefore there would be little chance of surge and spikes passes.
- If there is problem in change over circuit it shutdown the PC.



Line Interactive UPS

Line interactive Ups work like online and offline Ups.



Line Interactive UPs

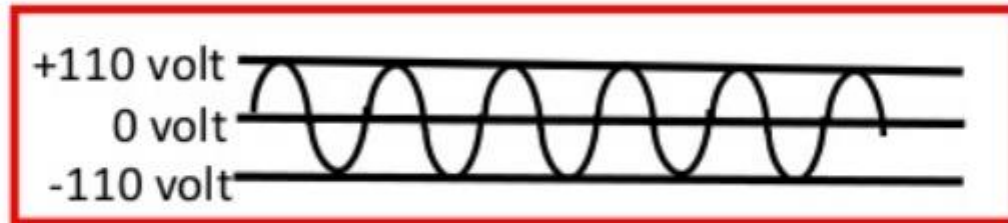
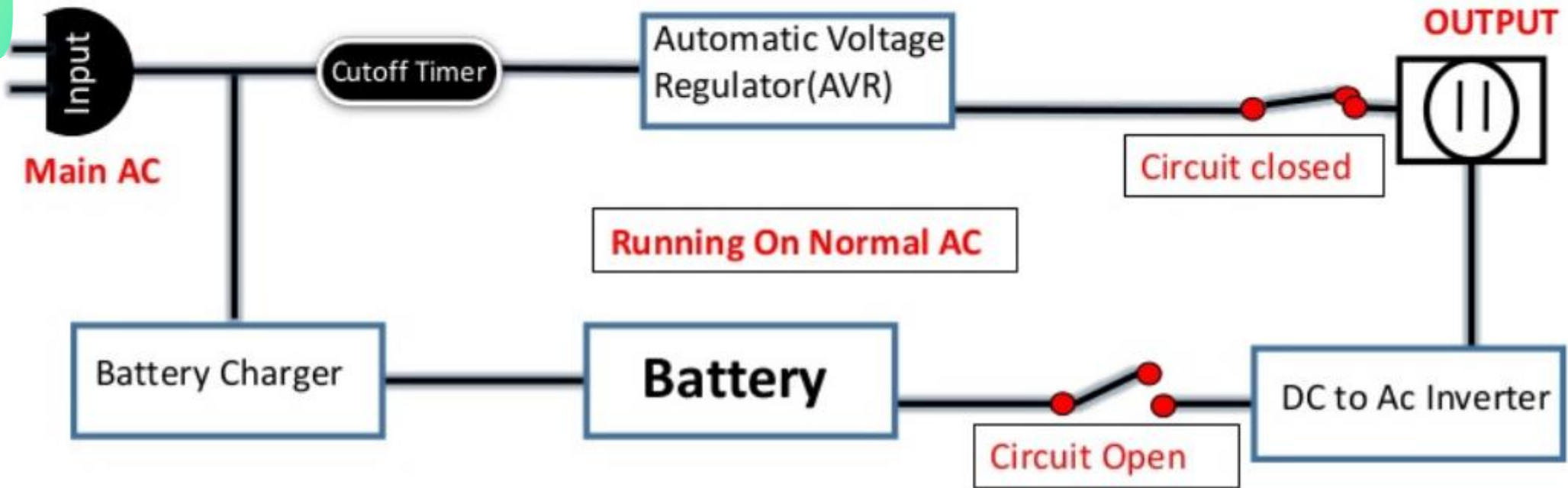

When main Ac flows normal ,it works like offline UPs



Line Interactive UPs

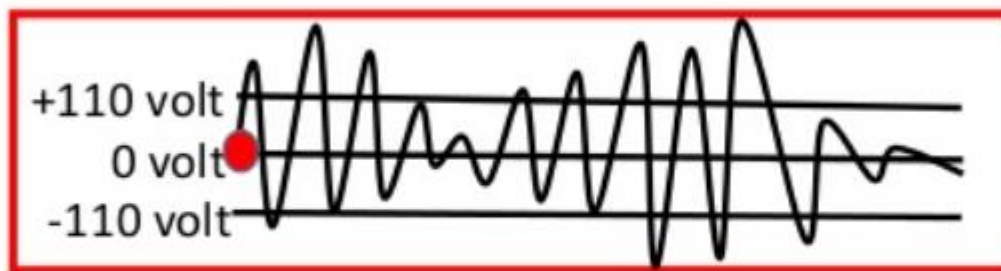
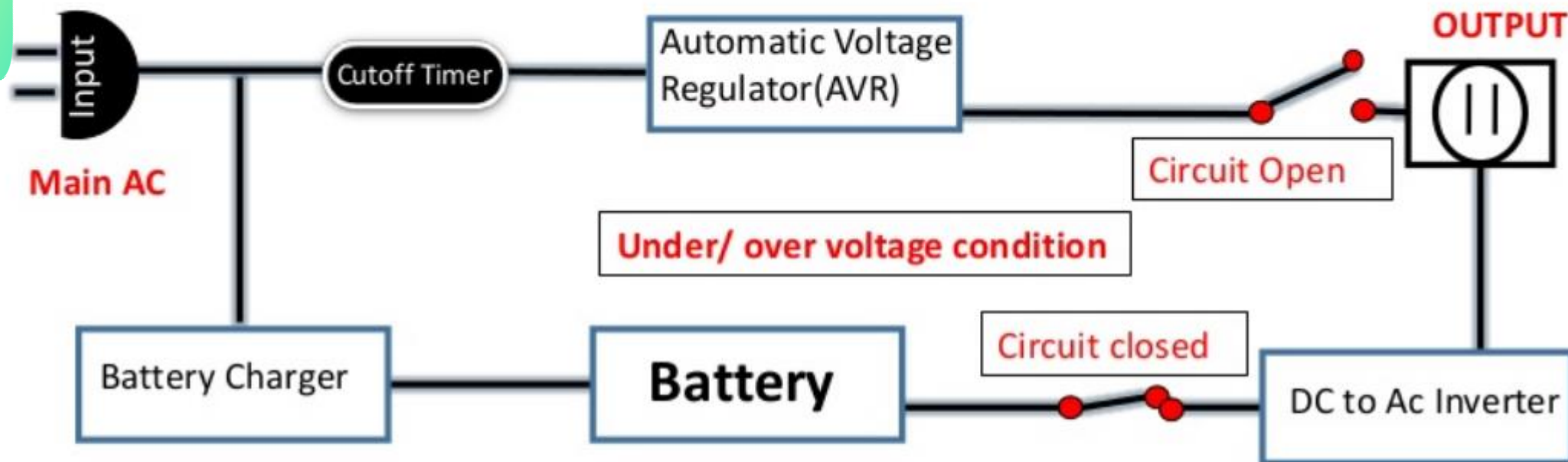

When there is fluctuation in Main AC, Cutoff timer cut the path of AC through AVR for specific time thus charge flow through the Battery. At this state ups works as Online UPS



Advantage of Line Interactive UPS

- Output power accuracy of line interactive Ups is higher than offline Ups because it passes Main Ac through Battery if there is fluctuation in Main AC.
- If there is no fluctuation in Main AC then it bypass through AVR(automatic voltage regulator)which can save Batt. Life.



Disadvantage of Line Interactive UPs

- Output power supplies of accuracy is less than online Ups because it works on both AC and battery mode.
- System may shutdown if there is problem comes in **change over circuit.**

