



# Voltage regulators, Filters



# What is Voltage Regulation



A **voltage regulator** is an electronic or electrical device that can sustain the voltage of power supply within suitable limits. The electrical equipment connected to the voltage source should bear the value of the voltage. The source voltage should be in a certain range which is acceptable for the connected pieces of equipment. This purpose is fulfilled by implementing a voltage regulator.

A voltage regulator – as the name suggests – regulates the voltage, regardless of the adjustments in the input voltage or connected load. It works as a shield for protective devices from damage. It can regulate both AC or DC voltages, depending on its design.



# Voltage Regulator- Block diagram

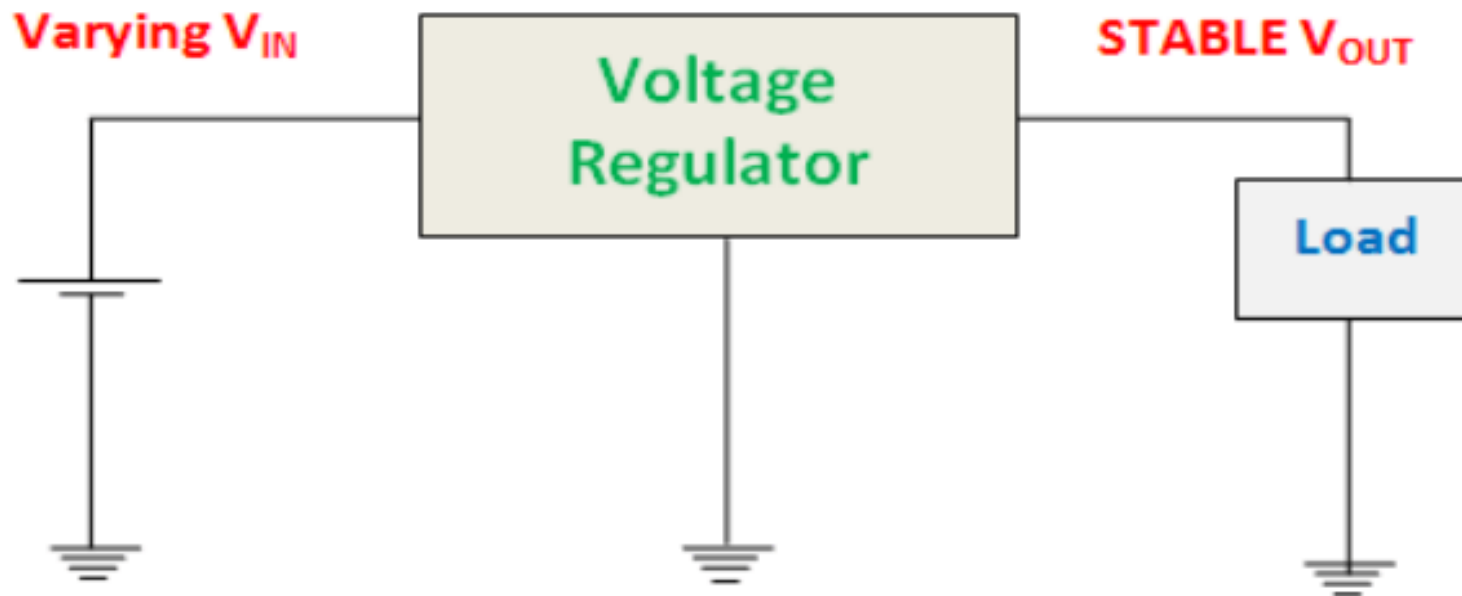



---

There are two main types of voltage regulators available:

- Linear Voltage Regulators
- Switching Voltage Regulators

These can be further classified into more specific voltage regulators, as discussed below.

## Linear Voltage Regulator

This type of voltage regulator performs as a **voltage divider**. It employs **FET** in Ohmic region. The steady output is sustained by varying the **resistance** of voltage regulator with respect to the load. Generally, these types of voltage regulator are of two types:

- Series voltage regulator
- Shunt voltage regulator



## Discrete Transistor Series Voltage Regulator

Here from the block diagram, we can see an unregulated input is first fed into a **controller**. It actually controls the input voltage magnitude and given to the output. This output is given to the feedback circuit. It is sampled by the sampling circuit and given to the comparator. There it is compared by the reference voltage and given back to the output.

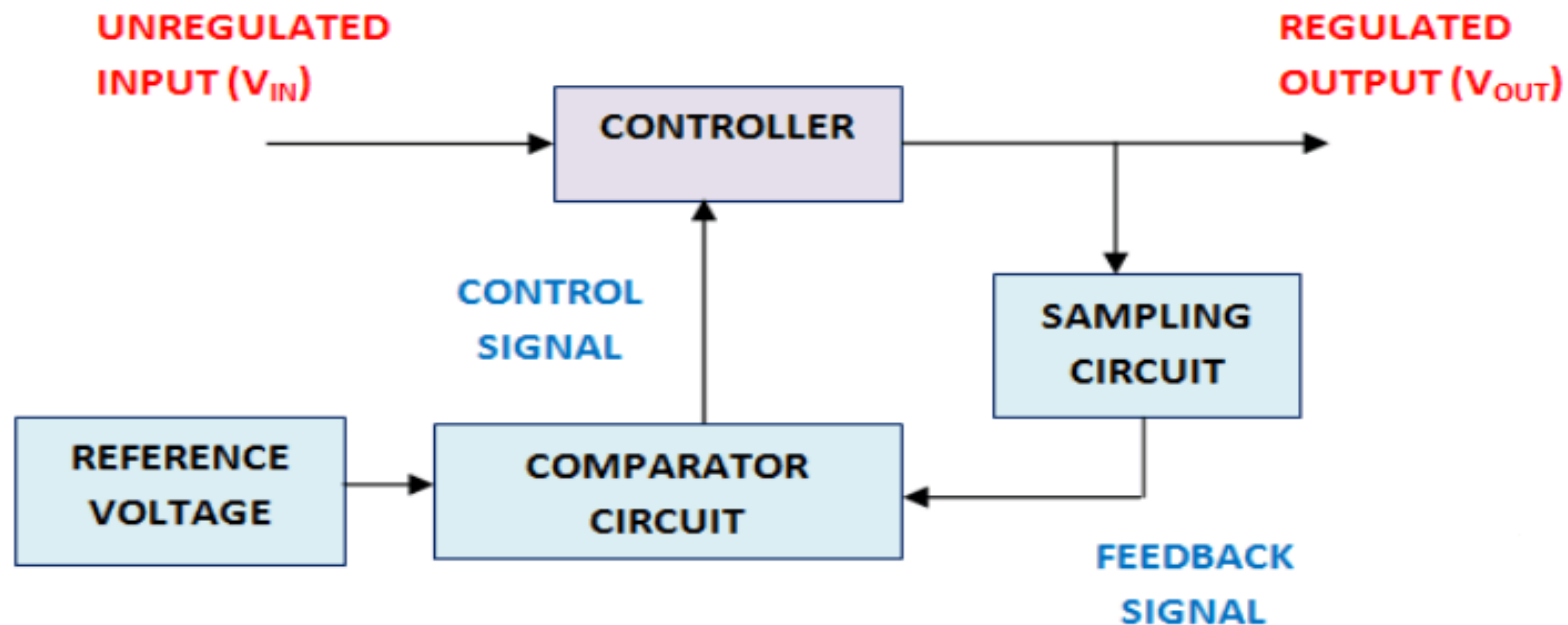



## Zener Diode as Voltage Regulator

When a **Zener diode** is used as a voltage regulator, it is known as a Zener controlled transistor series voltage regulator or an emitter follower voltage regulator. Here, the **transistor** used is emitter follower (see figure below). The emitter and the collector terminals of the series pass transistor used here are in series with respect to load. The variable element is a transistor and the Zener diode will supply the reference voltage.

$$V_{OUT} = V_{Zener} + V_{BE}$$

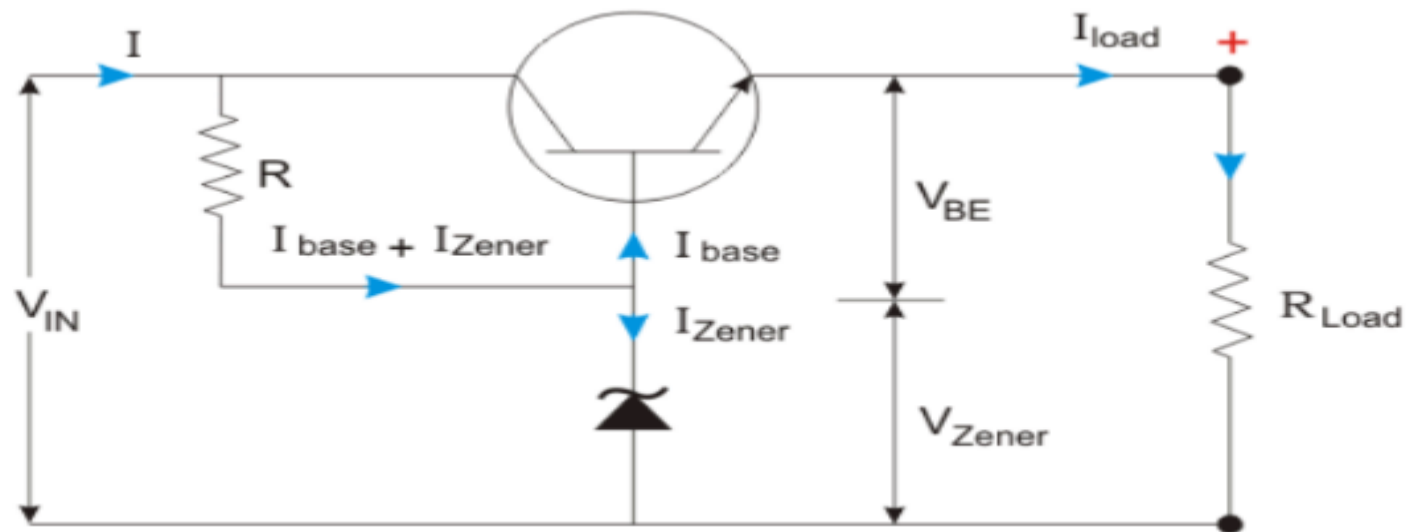



## Filter Circuits

To remove the AC components or filter them out in a rectifier circuit, a filter circuit is used. A filter circuit is a device to remove the A.C components of the rectified output, but allows the D.C components to reach the load. A filter circuit is in general a combination of inductor (L) and Capacitor (C) called LC filter circuit. A capacitor allows A.C only and inductor allows D.C only to pass. So a suitable L and C network can effectively filter out the A.C component from rectified wave.

A filter circuit consists of passive circuit elements i.e, inductors, capacitors, resistors and their combination. The filter action depends upon the electrical properties of passive circuit elements. For example, an inductor allows the D.C to pass through it. But it blocks A.C. On the other hand, a capacitor allows the A.C to pass through it. But it blocks the D.C. Some of the important filters are given below.

1. Inductor Filter
2. Capacitor Filter
3. LC Filter
4.  $\pi$  Filter



# Inductor Filter

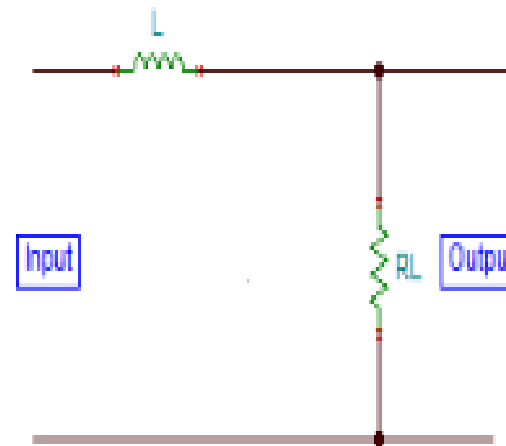

This type of filter is also called choke filter. It consists of an inductor  $L$  which is inserted between the rectifier and the load resistance  $R_L$ . The rectifier contains A.C components as well as D.C components. When the output passes through the inductor, it offers a high resistance to the A.C component and no resistance to D.C components. Therefore, A.C components of the rectified output is blocked and only D.C components reached at the load.

Navigation icons: back, forward, search, etc.





# Capacitor Filter

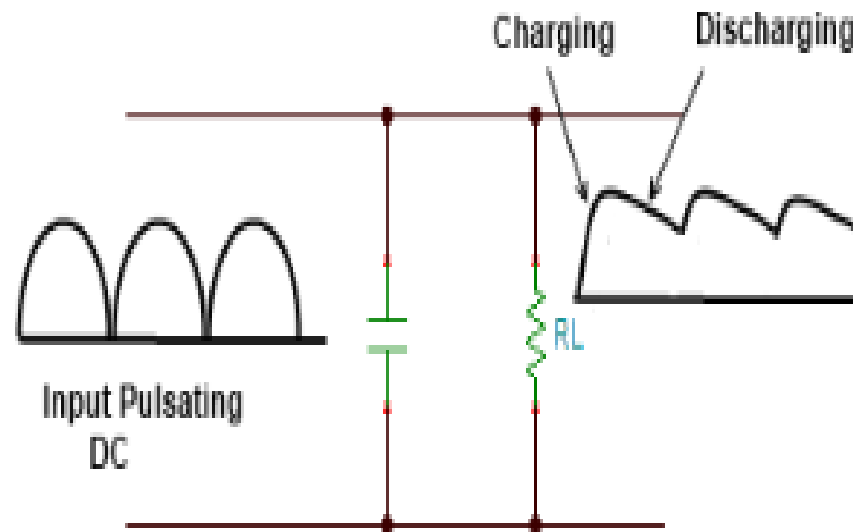

In this filter a capacitor is connected across the load during the rise of voltage cycle it gets charge and this charge is supply to the load during the fall in the voltage cycle. This process is repeated for each cycle and thus the ripple is reduced across the load. It is shown in the above Figure. It is popular, because of its low cost, small size, less weight and good characteristics. Useful for load up to 50mA as in transistor radio battery eliminators.



# LC Filter

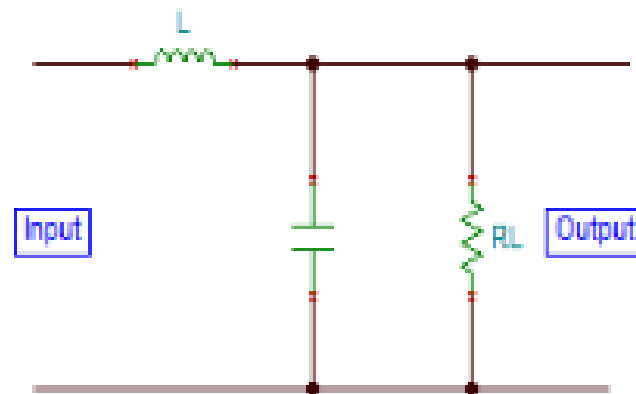

In inductor filter, the ripple factor is directly proportional to the load resistance. On the other hand in a capacitor filter, it is varying inversely with the load resistance. Hence if we combine the inductor filter with the capacitor the ripple factor will become almost independent of the load filter. It is also known as inductor input filter, choke input filter, L input or LC-section.

In this circuit a choke is connected in series with the load. It offers high resistances to the AC components and allows DC component to flow through the load. The capacitor across the load is connected in parallel which filter out any AC component flowing through the choke. In this way the reppls are rectified and a smooth DC is provided through the load.



## 2.1 Half-wave Rectifier with Capacitor Filter

### Half wave Rectifier with Capacitor Filter

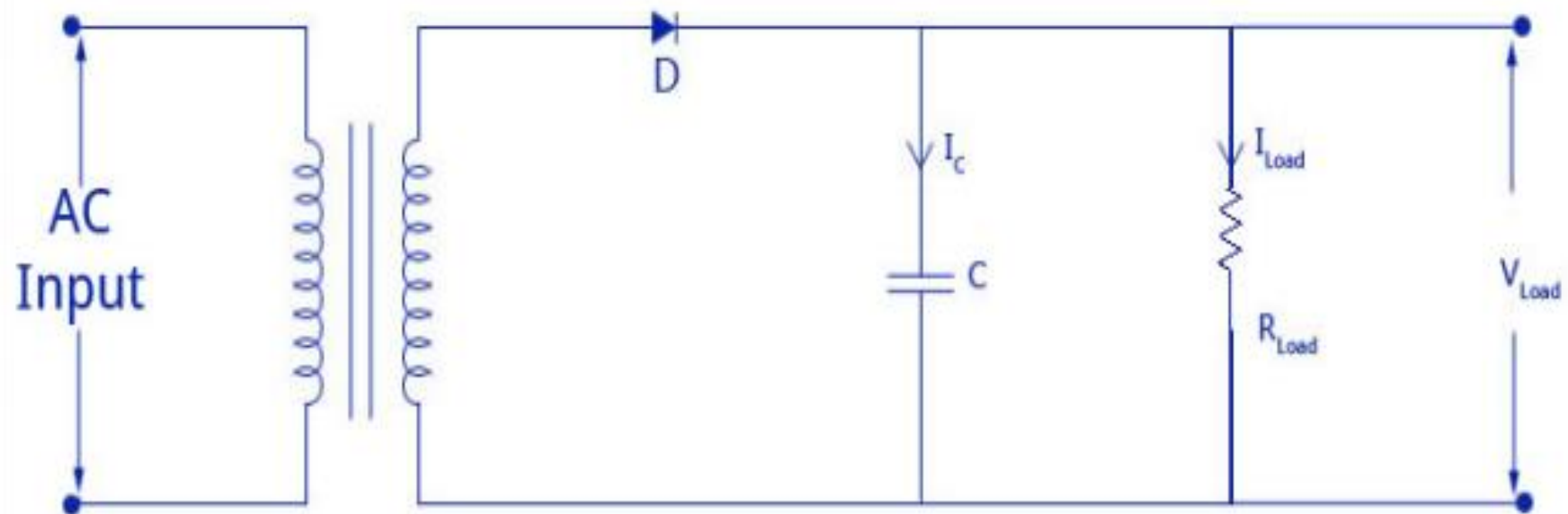



## Half wave Rectifier with Capacitor Filter - Waveform

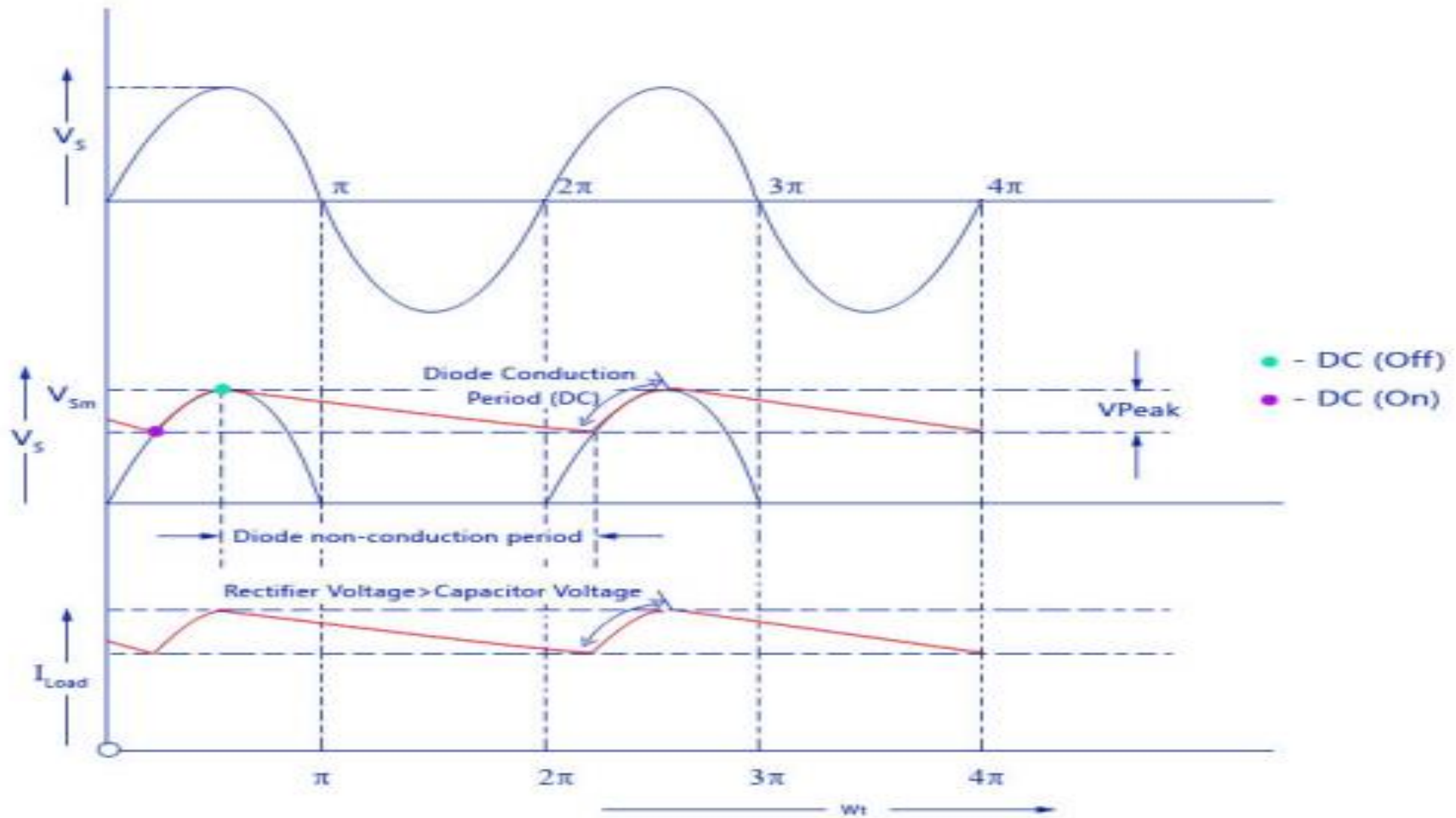



## 2.2 Full-wave Rectifier with Shunt Capacitor Filter

The circuit diagram of a full-wave rectifier with capacitor filter is shown below.

### Fullwave Rectifier with Capacitor Filter

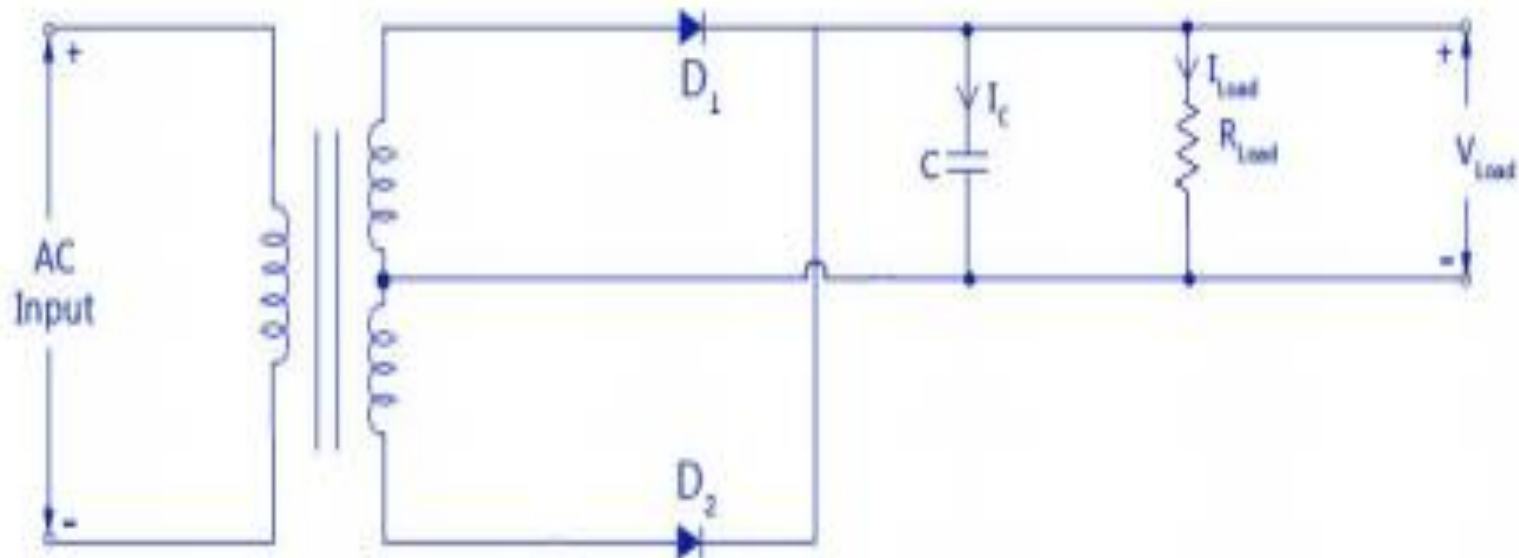



## Fullwave Rectifier with Capacitor Filter - Waveform

