

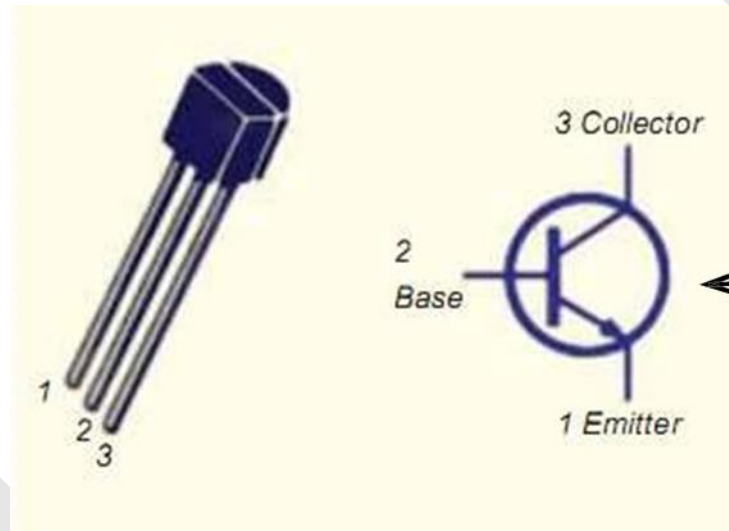

UNIT IV



BIPOLAR JUNCTION TRANSISTORS



Bipolar Junction Transistors

- The transistor is a three-layer semiconductor device consisting of either two n- and one p- type layers of material or two p- and one n- type layers of material.
- The former is called an npn transistor, while the latter is called a pnp transistor
- So, there are two types of BJT-
 - i) pnp transistor
 - ii) npn transistor



Bipolar Junction Transistors



In each transistor following points to be noted-

- i) There are two junction, so transistor can be considered as two diode connected back to back.
- ii) There are three terminals.
- iii) The middle section is thin than other.



Naming of Transistor Terminals

- Transistor has three section of doped semiconductor.
- The section one side is called “emitter” and the opposite side is called “collector”.
- The middle section is called “base”.

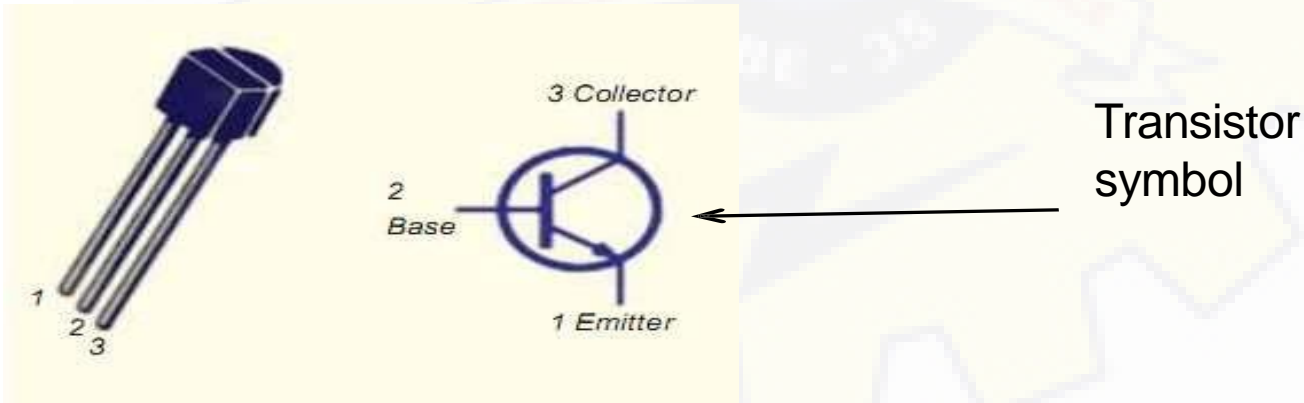



Naming of Transistor Terminals

1) Emitter:

→ The section of one side that supplies carriers is called emitter.

→ Emitter is always forward biased wr to base so it can supply carrier.

→ For “npn transistor” emitter supply holes to its junction.

→ For “pnp transistor” emitter supply electrons to its junction.



Naming of Transistor Terminals

2) Collector:

- The section on the other side that collects carrier is called collector.
- The collector is always reversed biased wr to base.

3) Base:

- The middle section which forms two pn junction between emitter and collector is called Base.



Some important factors to be remembered-

- The transistor has three region named emitter, base and collector.
- The Base is much thinner than other region.
- Emitter is heavily doped so it can inject large amount of carriers into the base.
- Base is lightly doped so it can pass most of the carrier to the collector.
- Collector is moderately doped.



Some important factors to be remembered-

- The junction between emitter and base is called emitter-base junction(emitter diode) and junction between base and collector is called collector-base junction(collector diode).
- The emitter diode is always forward biased and collector diode is reverse biased.
- The resistance of emitter diode is very small(forward) and resistance of collector diode is high(reverse).



Transistor Operation

1) Working of npn transistor:

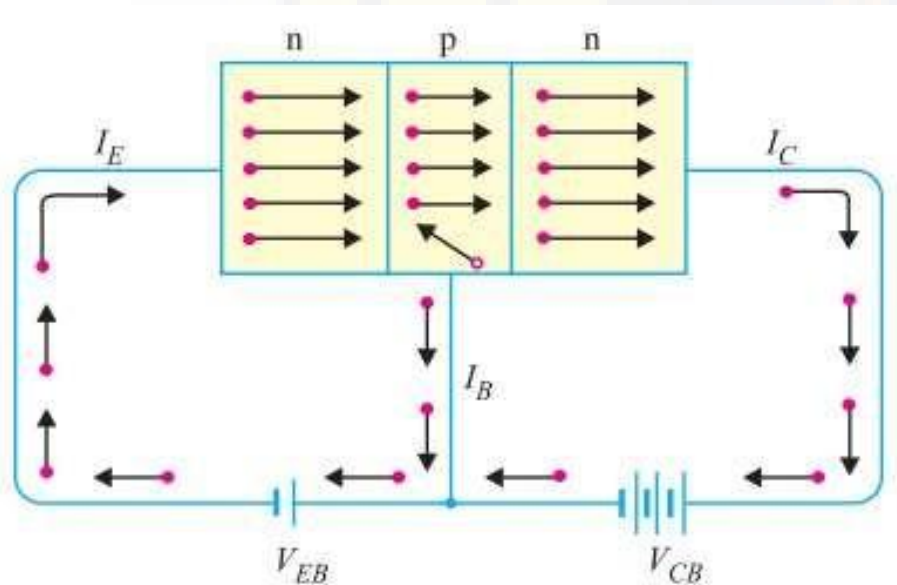

✓ Forward bias is applied to emitter-base junction and reverse bias is applied to collector-base junction.

✓ The forward bias in the emitter-base junction causes electrons to move toward



Transistor Operation

1) Working of npn transistor:

- ✓ As this electrons flow toward p-type base, they try to recombine with holes. As base is lightly doped only few electrons recombine with holes within the base.
- ✓ These recombined electrons constitute small base current.
- ✓ The remainder electrons crosses base and constitute $I_E = I_B + I_C$ current.



Transistor Operation

2) Working of pnp transistor:

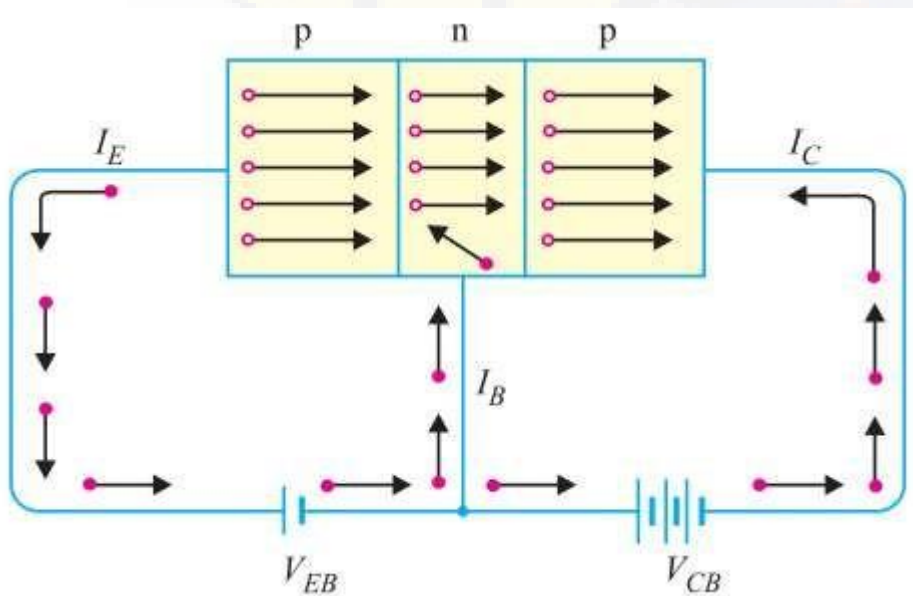

✓ Forward bias is applied to emitter- base junction and reverse bias is applied to collector- base junction.

✓ The forward bias in the emitter-base junction causes holes to move toward



Transistor Operation

2) Working of pnp transistor:

- ✓ As this holes flow toward n-type base, they try to recombine with electrons. As base is lightly doped only few holes recombine with electrons within the base.
- ✓ These recombined holes constitute small base current.
- ✓ The remainder holes crosses base and constitute collector current.



Transistor Symbol

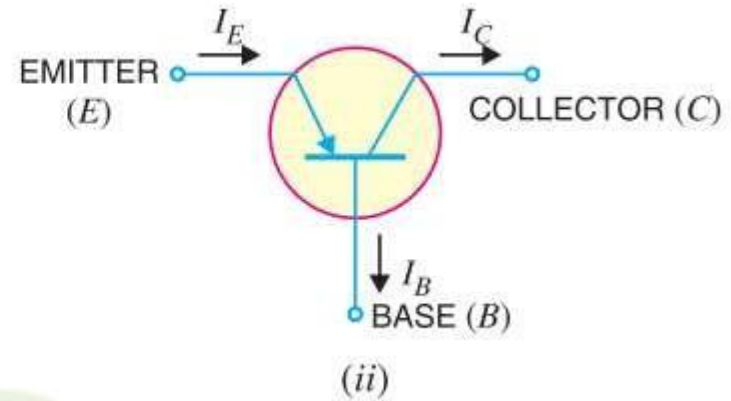
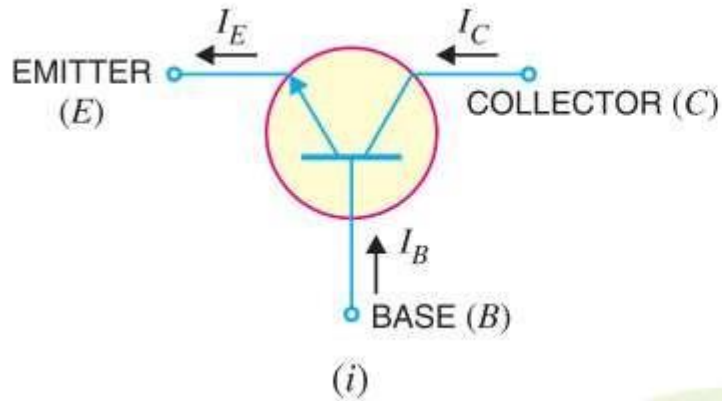
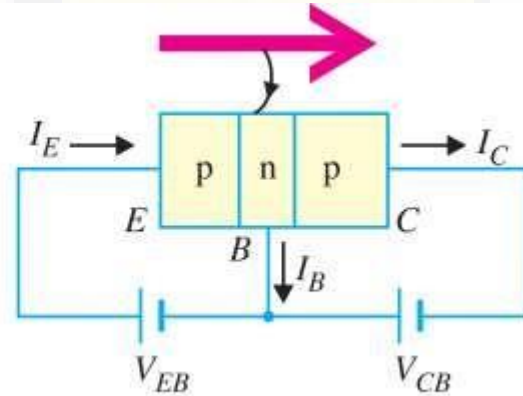
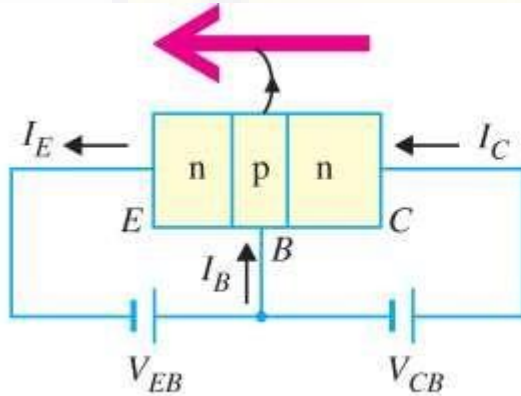



Transistor Connection

- Transistor can be connected in a circuit in following three ways-
- 1) Common Base
 - 2) Common Emitter
 - 3) Common Collector



Transistor Connection

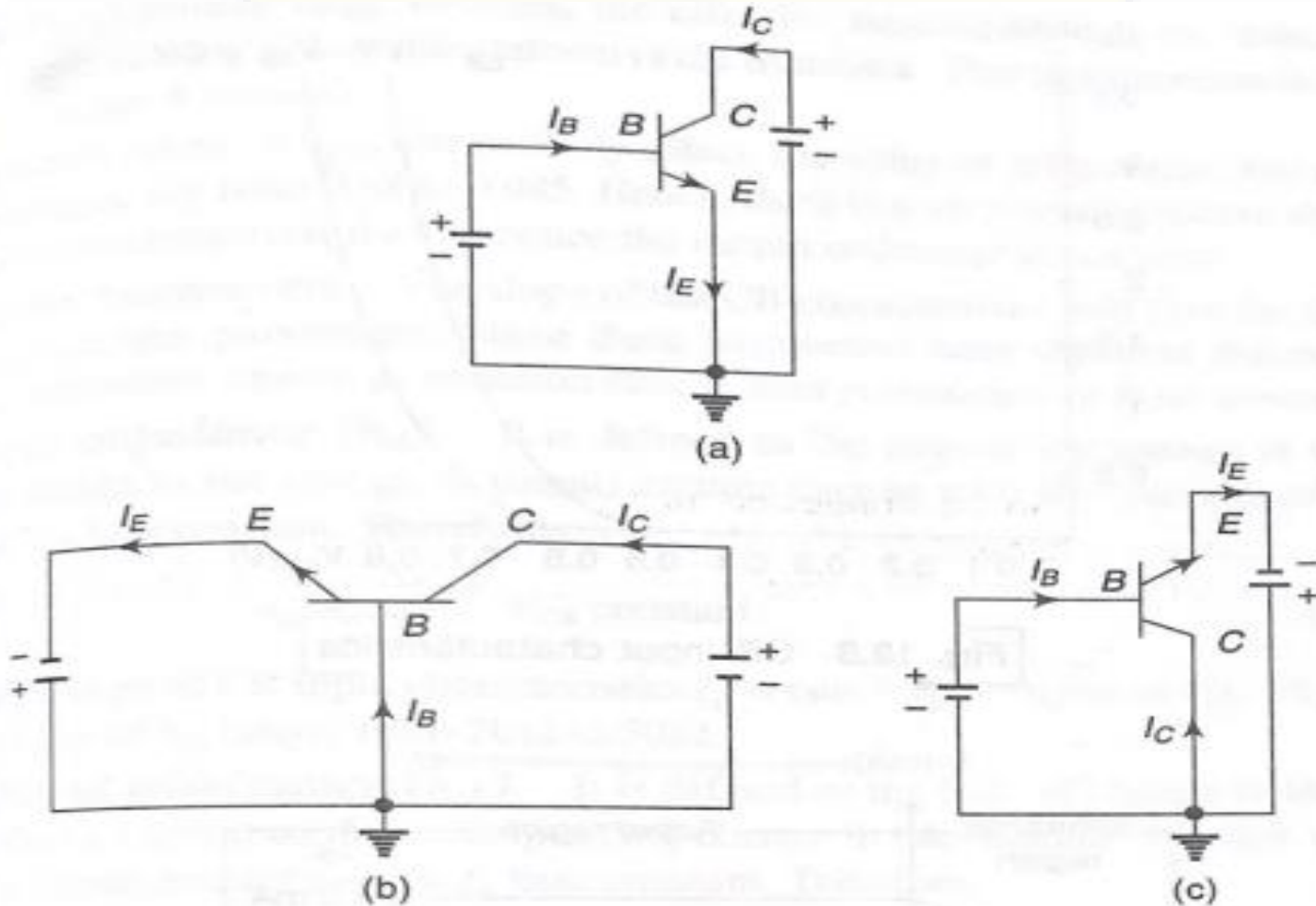

Fig. 13.6 Transistor configuration: (a) common base (b) common emitter and (c) common collector



Common Base Connection

- The common-base terminology is derived from the fact that the base is common to both the input and output sides of the configuration.

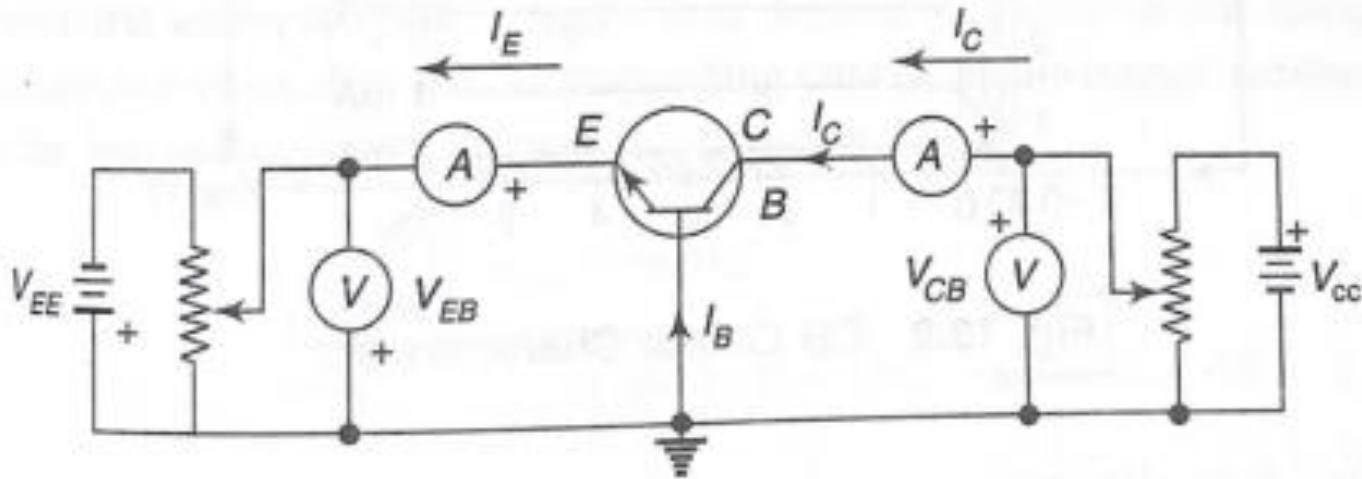

Fig. 13.7 Circuit to determine CB static characteristics



Common Base Connection

- Current amplification factor (α) :

The ratio of change in collector current to change in emitter current at constant V_{CB} is known

$$\alpha = \frac{\Delta I_C}{\Delta I_E} \text{ at constant } V_{CB}$$

→ Practical value of α is less than unity, but in the range of 0.9 to 0.99



Expression for Collector Current

→ Total emitter current does not reach the collector terminal, because a small portion of it constitute base current. So,

$$I_E = I_C + I_B$$

▪



Characteristics of common base configuration

- Input Characteristics:

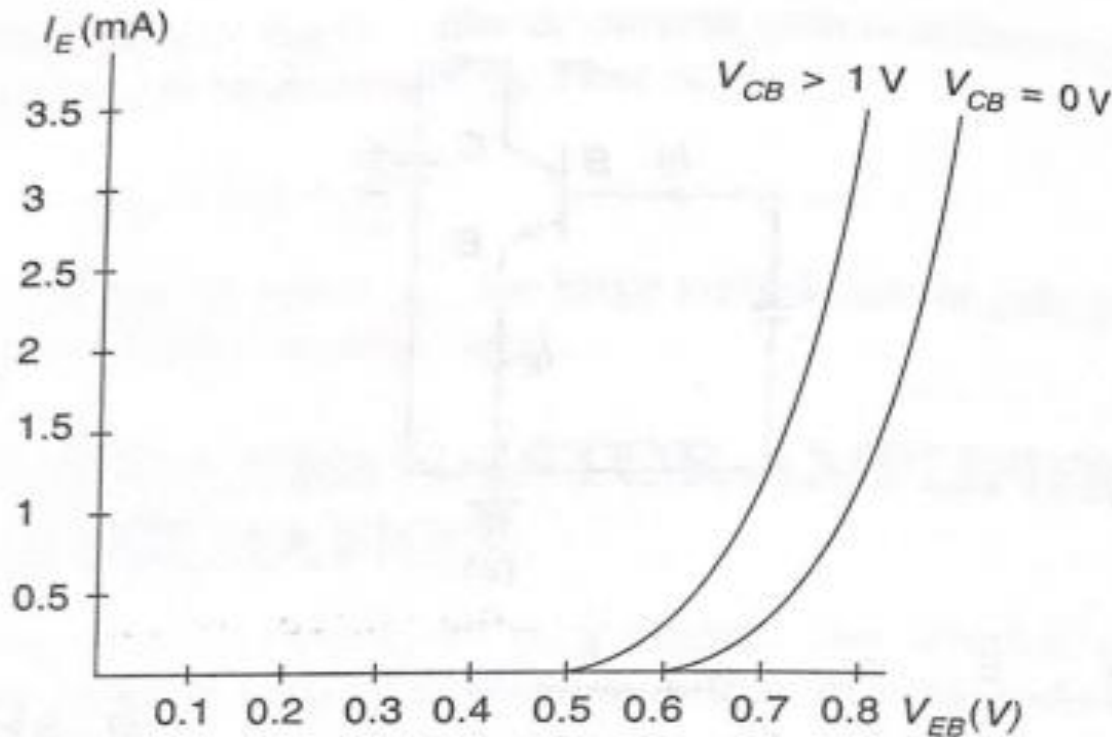

Fig. 13.8 CB Input characteristics



Characteristics of common base configuration

Output

Characteristics:

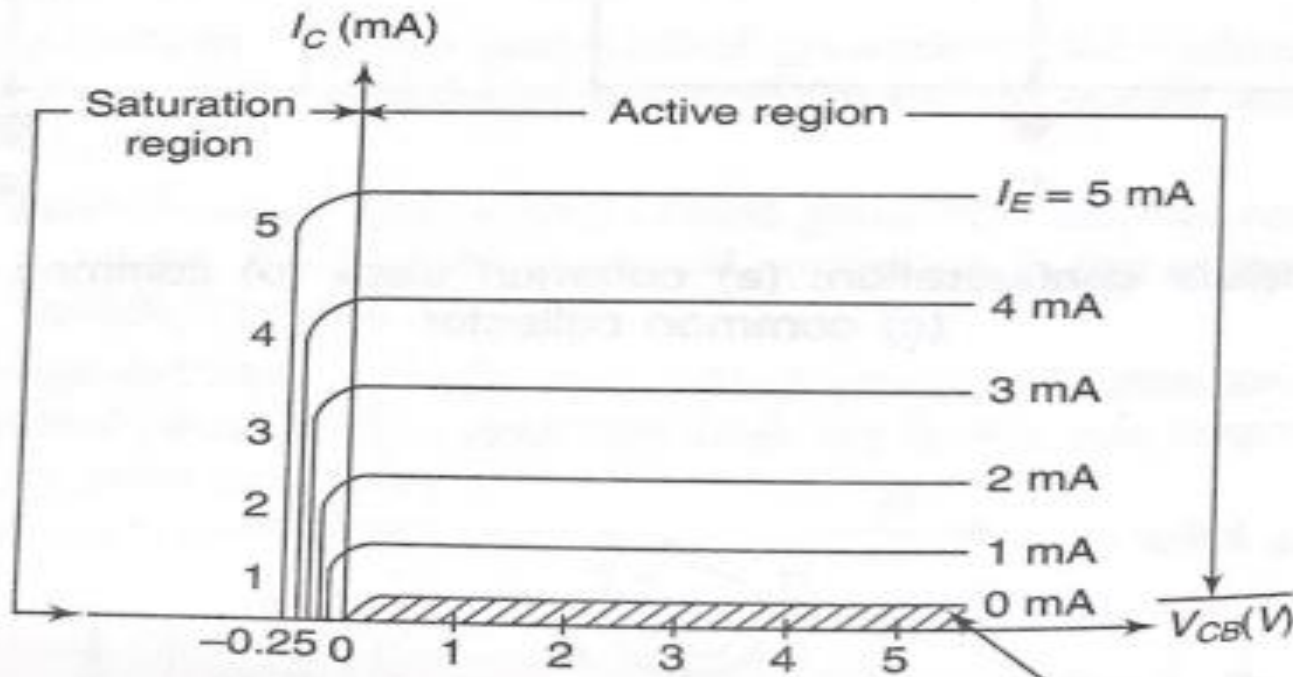

Fig. 13.9 CB Output Characteristics



Common Emitter Connection

- The common-emitter terminology is derived from the fact that the emitter is common to both the input and output sides of the configuration.

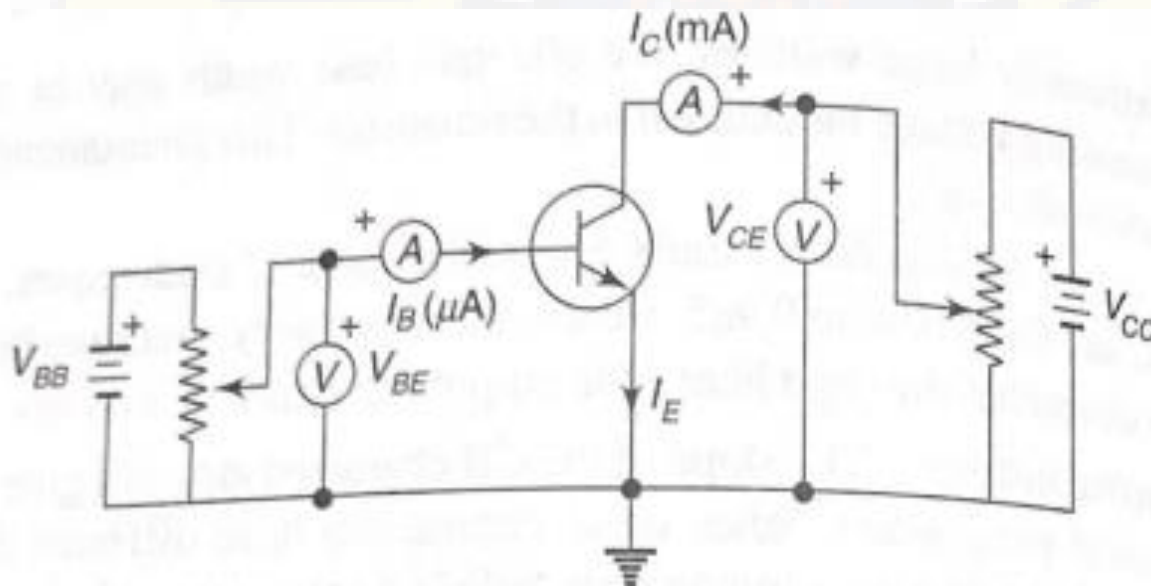

Fig. 13.10 Circuit to determine CE static characteristics



Common Emitter Connection

- Base Current amplification factor (β) :
- The ratio of change in collector current to the change in base current is known as base current

$$\beta = \frac{\Delta I_C}{\Delta I_B}$$

- Usually this range varies from 20 to 500.



Relation Between β and α

$$\beta = \frac{\Delta I_C}{\Delta I_B}$$

$$\alpha = \frac{\Delta I_C}{\Delta I_E}$$

$$\beta = \frac{\Delta I_C}{\Delta I_E - \Delta I_C}$$

$$\beta = \frac{\alpha}{1 - \alpha}$$



Characteristics of common emitter configuration

- Input Characteristics:

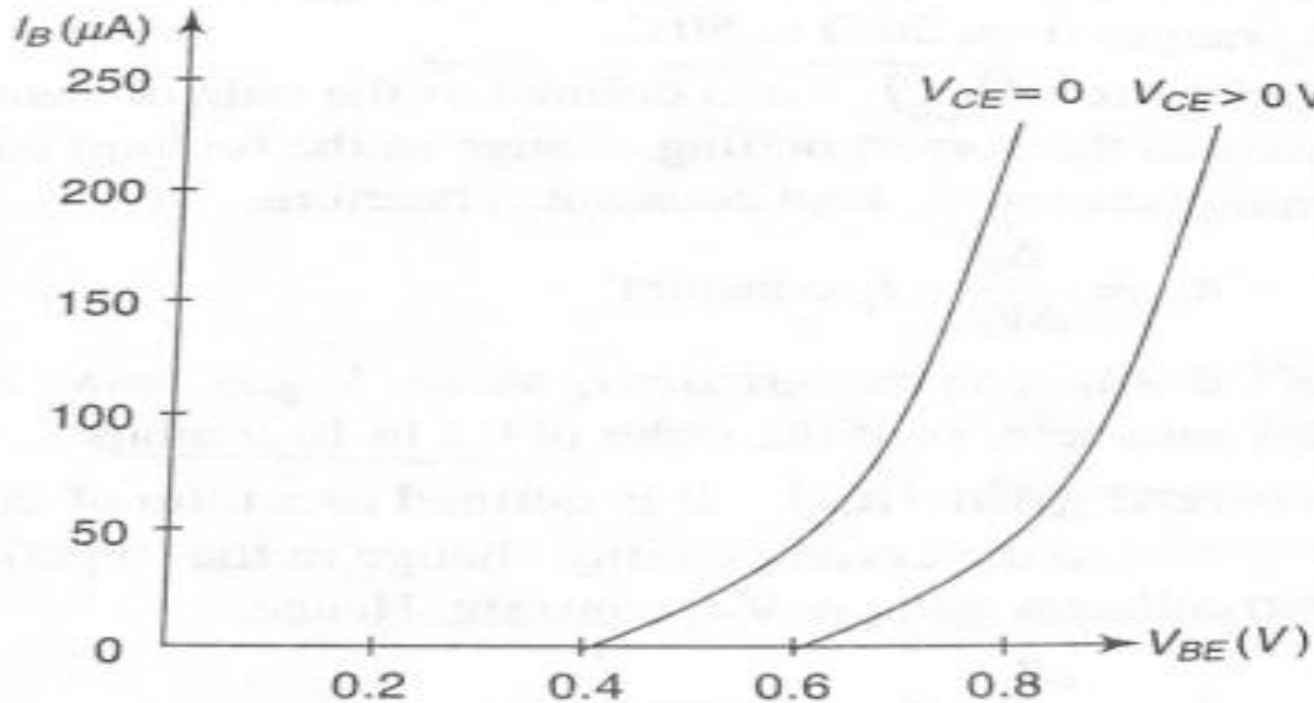



Common Collector Configuration

- The common-collector terminology is derived from the fact that the collector is common to both the input and output sides of the configuration.

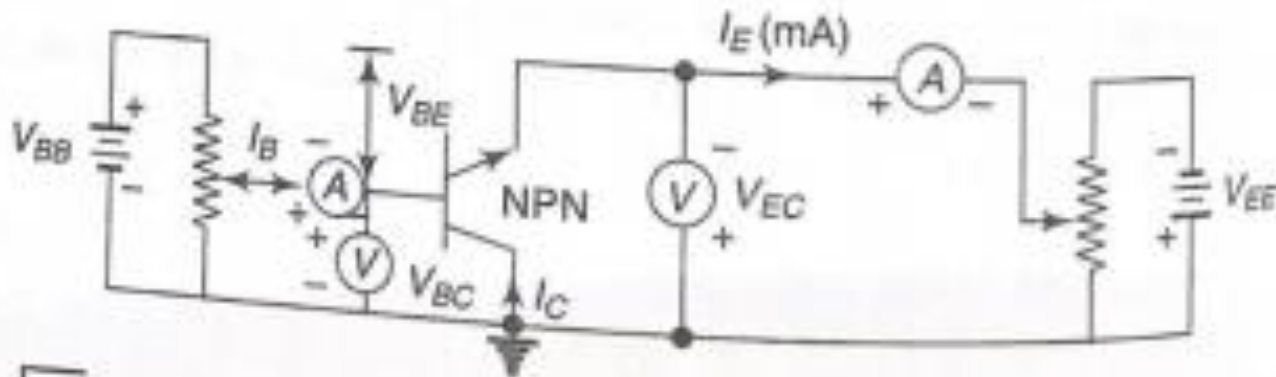

Fig. 13.13 Circuit to determine CC static characteristics



Common Collector Configuration

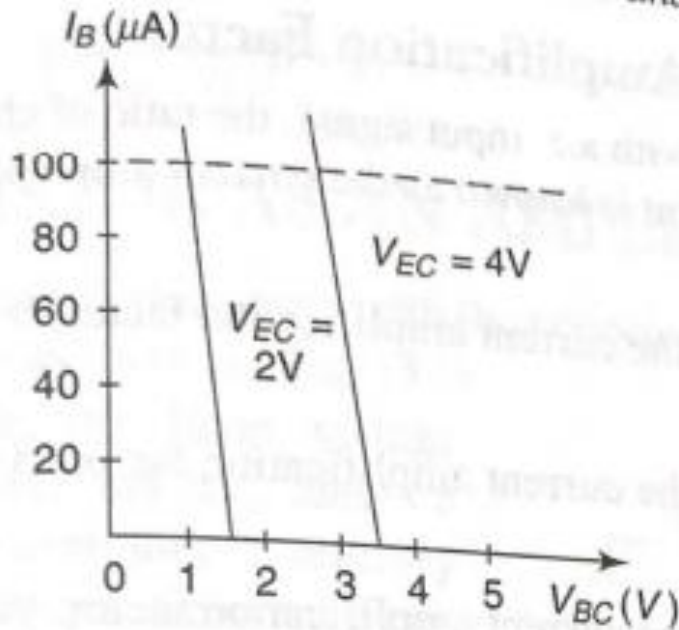

Fig. 13.14 CC input characteristics

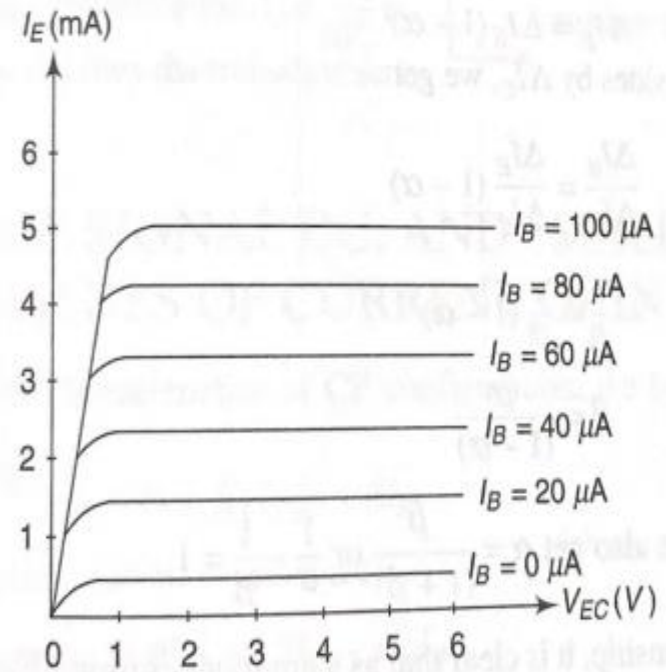

Fig. 13.15 CC output characteristics



Common Collector Configuration

- Current amplification factor (γ) :
- In common emitter connection input current is base current and output current is emitter current.
- The ratio of change in emitter current to the change in base current is known as current amplification

$$\gamma = \frac{\Delta I_E}{\Delta I_B}$$



Comparison of Transistor Connection

S. No.	Characteristic	Common base	Common emitter	Common collector
1.	Input resistance	Low (about 100 Ω)	Low (about 750 Ω)	Very high (about 750 k Ω)
2.	Output resistance	Very high (about 450 k Ω)	High (about 45 k Ω)	Low (about 50 Ω)
3.	Voltage gain	about 150	about 500	less than 1
4.	Applications	For high frequency applications	For audio frequency applications	For impedance matching
5.	Current gain	No (less than 1)	High (β)	Appreciable