

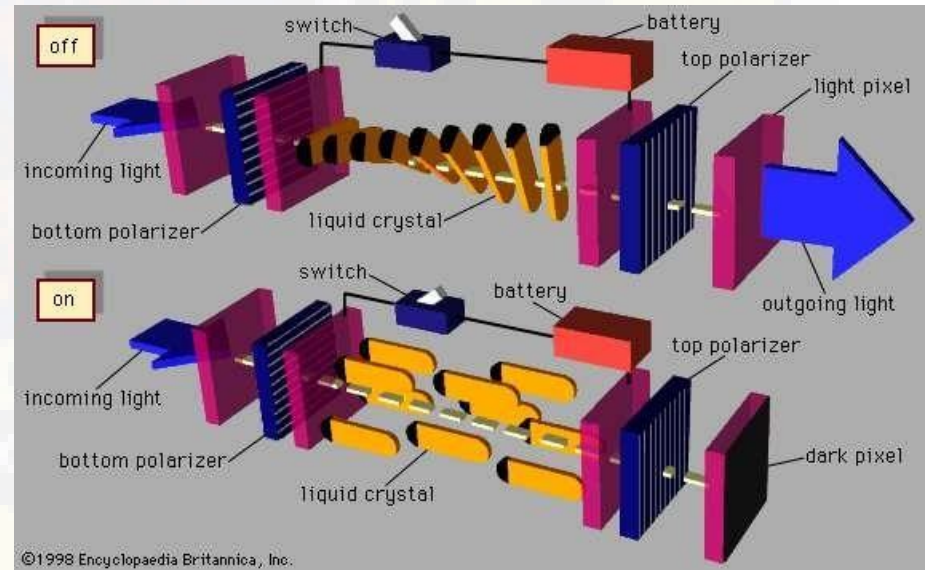

# UNIT IV



## LIQUID CRYSTAL DISPLAYS



# 1. What's Liquid Crystals (LC)

- intermediary substance between a liquid and solid state of matter.  
e.g. soapy water
- light passes through liquid crystal changes when it is stimulated by an electrical charge.



# Introduction

A Liquid Crystal Display (LCD) is a thin , flat panel display device used for electronically displaying information such as text ,images and moving picture.

- LCD is used in Computer monitors, Televisions , Instrument panels, Gaming devices etc.
- Polarization of lights is used here to display objects.



# Why LCD ?

- **Smaller size** —LCDs occupy approximately 60 percent less space than CRT displays an important feature when office space is limited.
- **Lower power consumption**—LCDs typically consume about half the power and emit much less heat than CRT displays.
- **Lighter weight** —LCDs weigh approximately 70 percent less than CRT displays of comparable size.
- **No electromagnetic fields** —LCDs do not emit electromagnetic fields and are not susceptible to them. Thus, they are suitable for use in areas where CRTs cannot be used.
- **Longer life** —LCDs have a longer useful life than CRTs.



# Examples of LCs

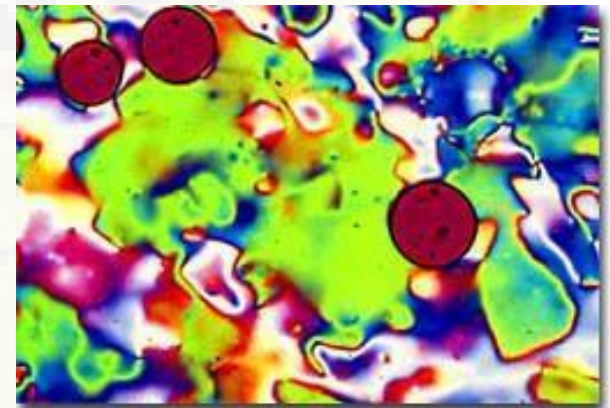
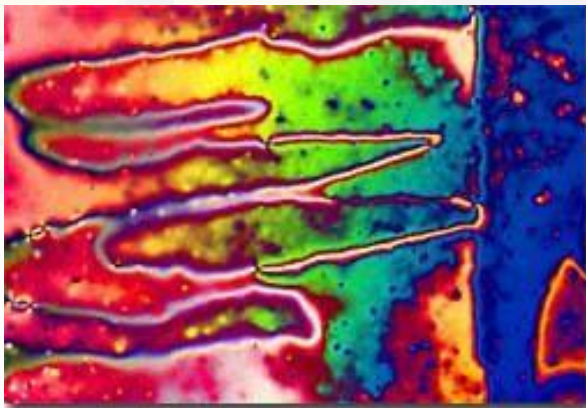
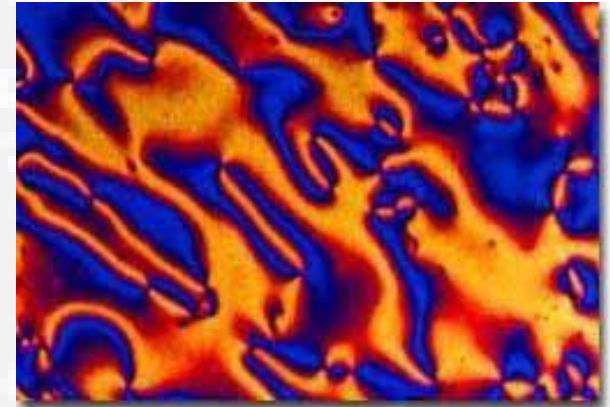
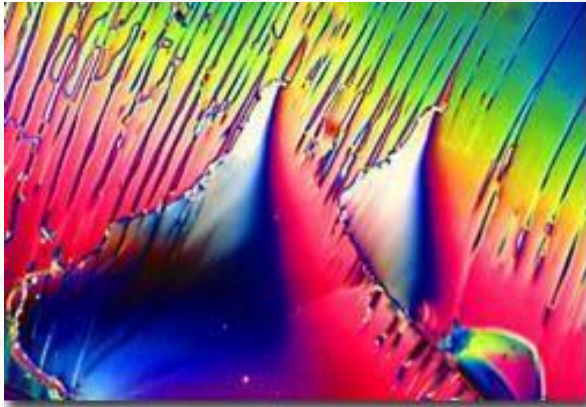



## 2. Introduction to Liquid Crystal Displays

- Consists of an array of tiny segments (called pixels) that can be manipulated to present information.
- Using polarization of lights to display objects.
- Use only ambient light to illuminate the display.
- Common wrist watch and pocket calculator to an advanced VGA computer screen



# Different types of LCDs

## **Passive Matrix LCDs (AMLCD) and Active Matrix LCDs (AMLCD)**

- Passive Twisted Nematic Displays (TNLCD)
- Super Twisted nematic LCD (STNLCD)
- Thin Film Transistor LCD (TFT LCD)
- Reflective LCD
- Rear Projection LCD

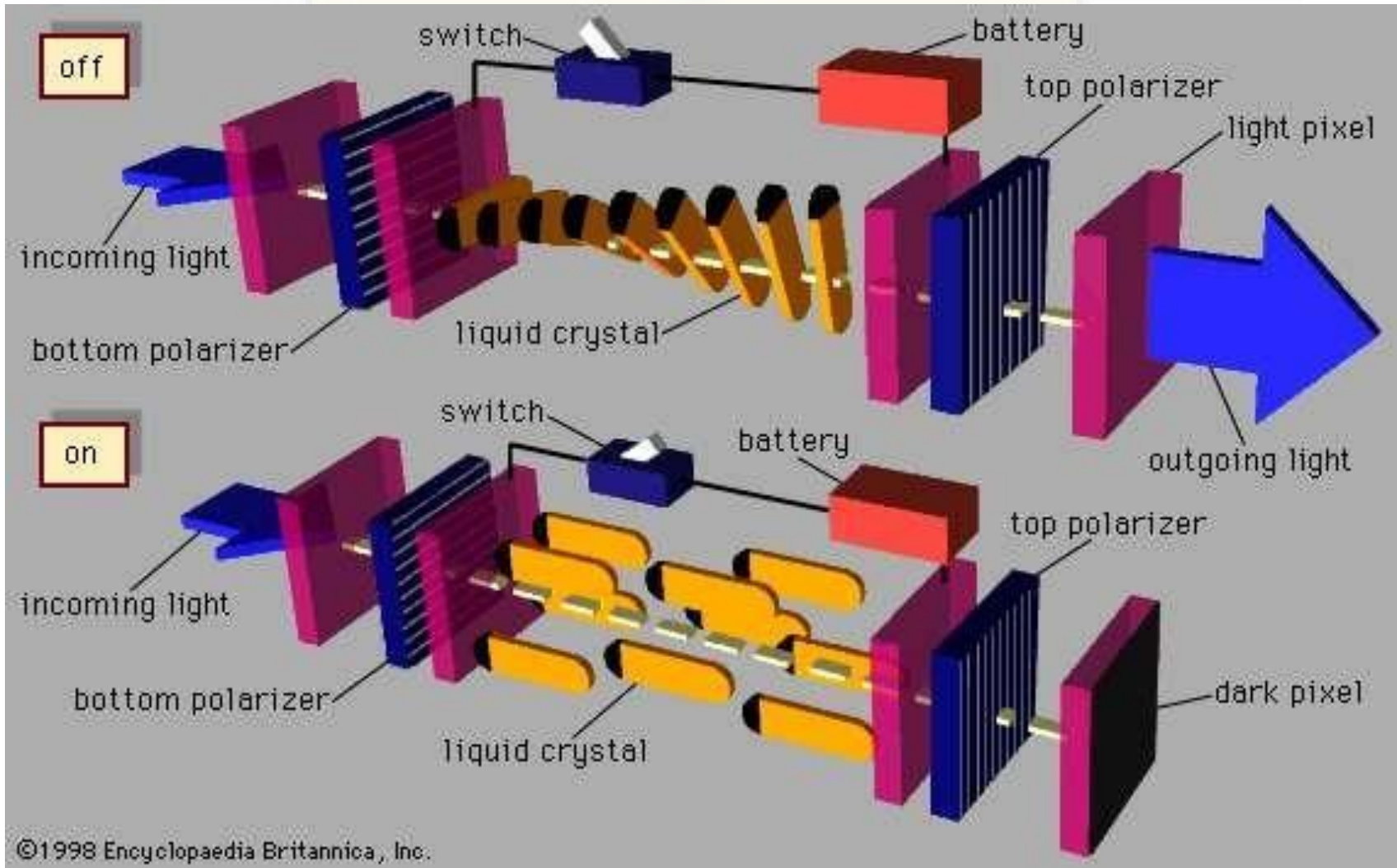





# Liquid Crystal Display (LCD)

- Light enters polarizer
- Nematic crystals twist based on voltage
- Allowing light to pass through to other

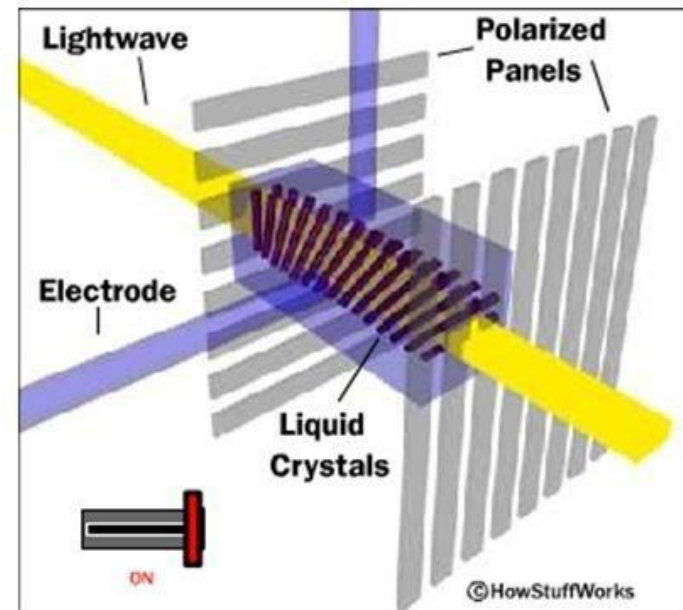
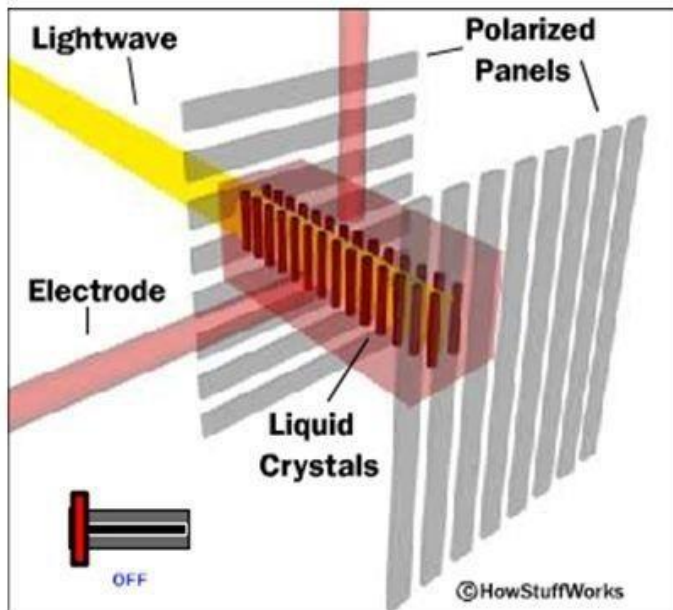



# Operating Principle

- The parallel arrangement of liquid crystal molecules along grooves
- When coming into contact with grooved surface in a fixed direction, liquid crystal molecules line up parallel along the **grooves**.

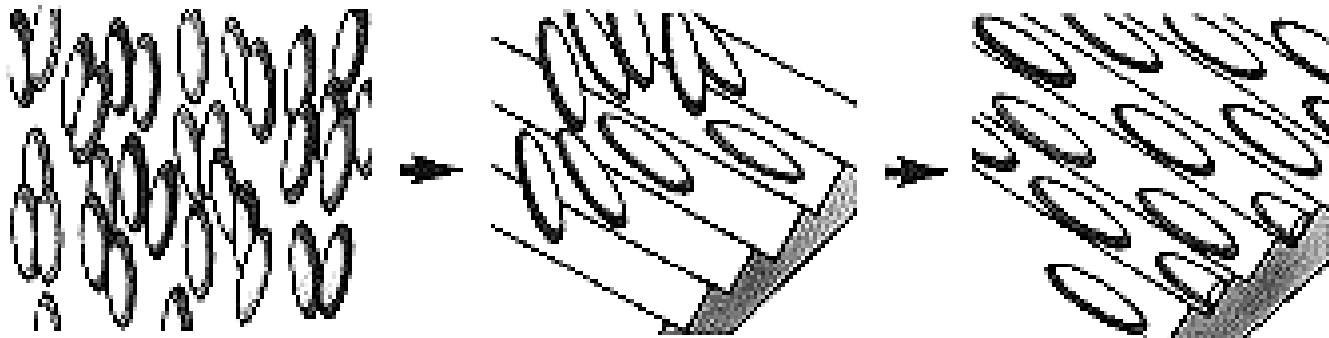



## 3. Operating Principle

### Molecules movement

*Offline (no voltage is applied)*

- Along the upper plate : Point in direction 'a'
- Along the lower plate : Point in direction 'b'
- Forcing the liquid crystals into a twisted structural arrangement. (Resultant force)

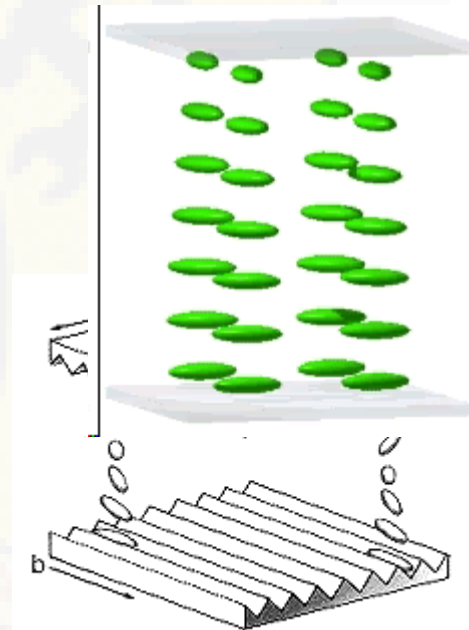



## 3. Operating Principle

### Light movement

*Offline (no voltage is applied)*

- Light travels through the spacing of the molecular arrangement.
- The light also "twists" as it passes through the twisted liquid crystals.
- Light bends 90 degrees as it follows the twist of the molecules.
- Polarized light pass through the analyzer (lower polarizer).

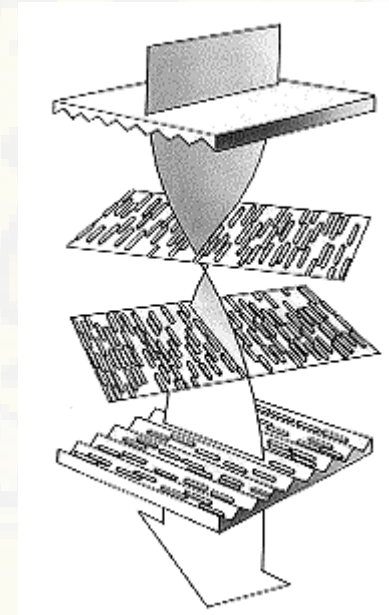



## 3. Operating Principle

### Molecules movement

*Online (voltage is applied)*

- Liquid crystal molecules straighten out of their helix pattern
- Molecules rearrange themselves vertically (Along with the electric field)
- No twisting throughout the movement
- Forcing the liquid crystals into a straight structural arrangement. (Electric force)

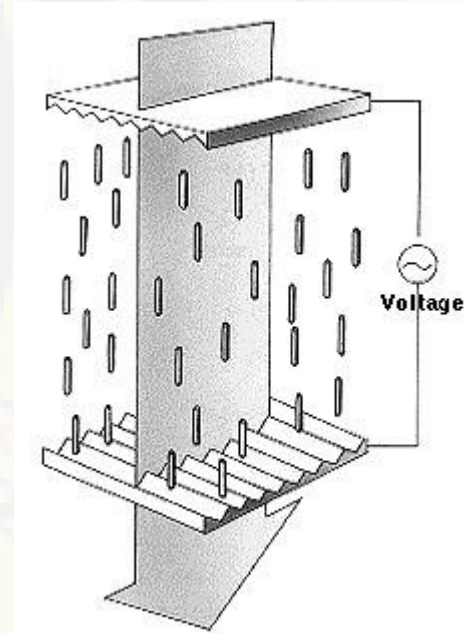



## 3. Operating Principle

### Light movement

*Online (voltage is applied)*

- Twisted light passes straight through.
- Light passes straight through along the arrangement of molecules.
- Polarized light cannot pass through the lower analyzer (lower polarizer).
- Screen darkens.

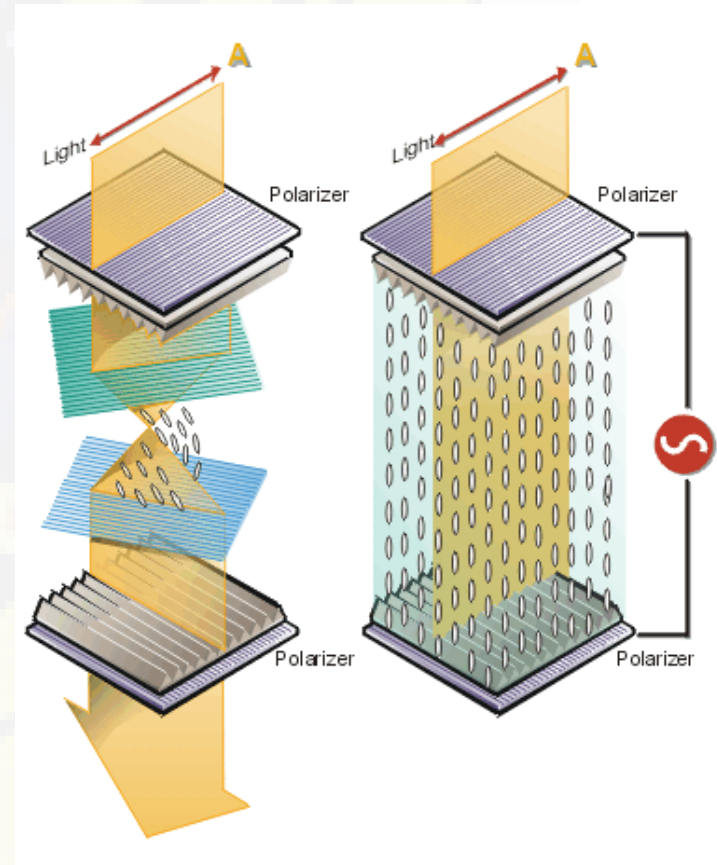



## 3. Operating Principle

Sequences of offline and online mode

### *Offline*

1. Surrounding light is polarized on the upper plate.
2. Light moves along with liquid crystals and twisted at right angle.
3. Molecules and lights are parallel to the lower analyzer.
4. Light passes through the plate.
5. Screen appear transparent.

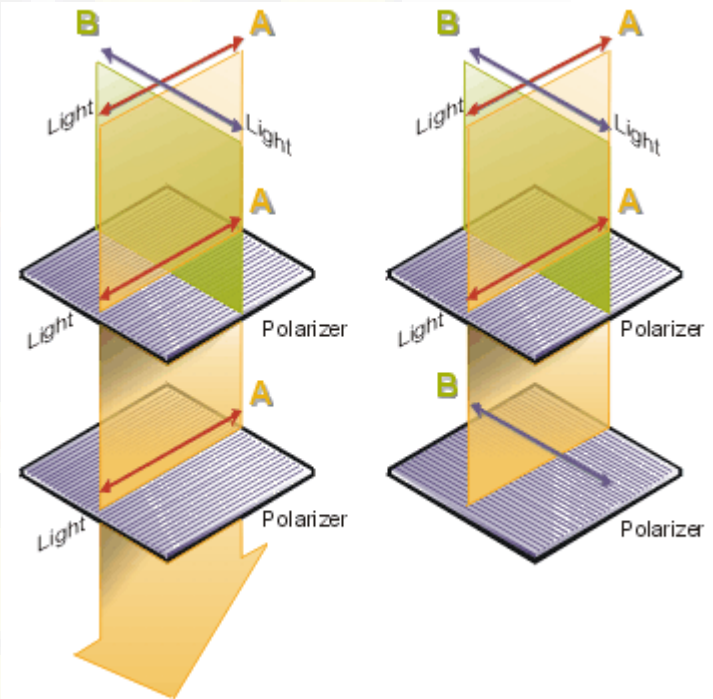

Offline

Online



## 3. Operating Principle

Sequences of offline and online mode

### *Online*

1. Surrounding light is polarized on the upper plate.
2. Light moves along with liquid crystals which moves straight along the electric field.
3. Molecules and lights are perpendicular to the lower analyzer.
4. Light cannot pass through the plate.
5. Screen appear dark.

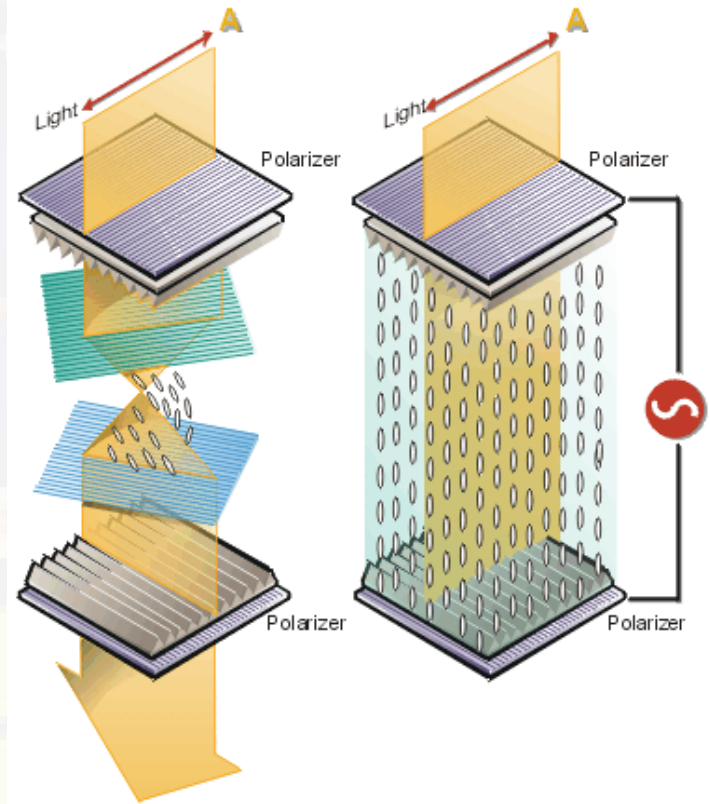

Offline

Online





# 3. Operating Principle

## Polarization of light

- When unpolarized light passes through a polarizing filter, only **one plane of polarization is transmitted**. Two polarizing filters used together transmit light differently depending on their relative orientation.

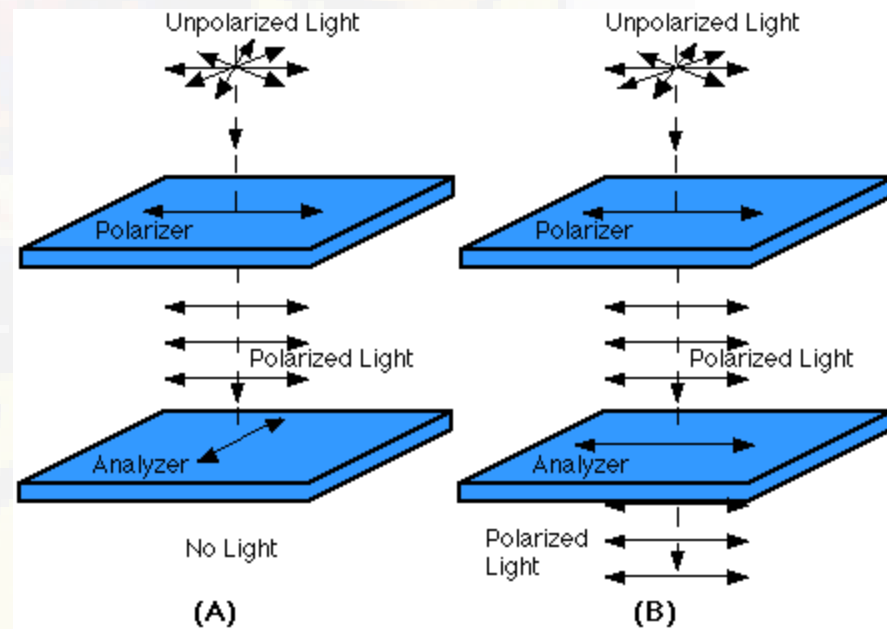
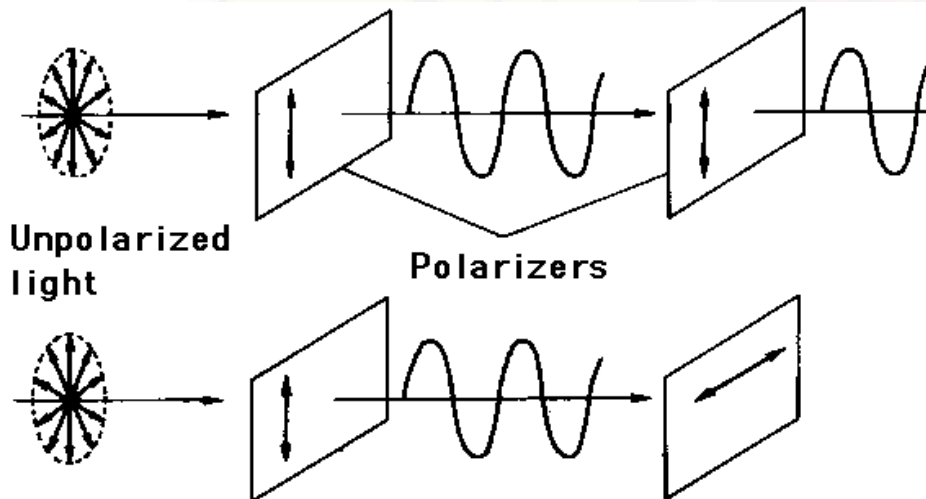



## 3. Operating Principle

### Construction of Liquid Crystal Display

- Two bounding plates (usually glass slides), each with a **transparent conductive coating** (such as indium tin oxide) that **acts as an electrode**;
- A polymer alignment layer : undergoes a rubbing process as grooves.
- **Spacers** to **control the cell gap precisely**;
- Two crossed polarizers (the **polarizer** and the **analyzer**);
- Polarizers are usually perpendicular to each other.

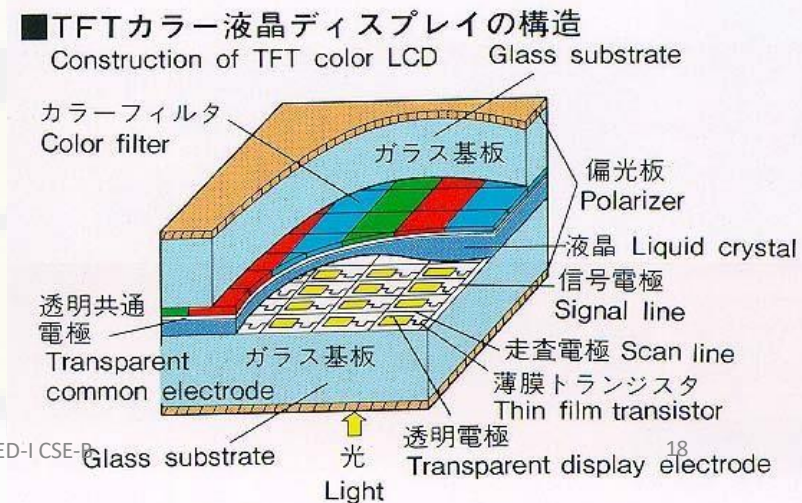
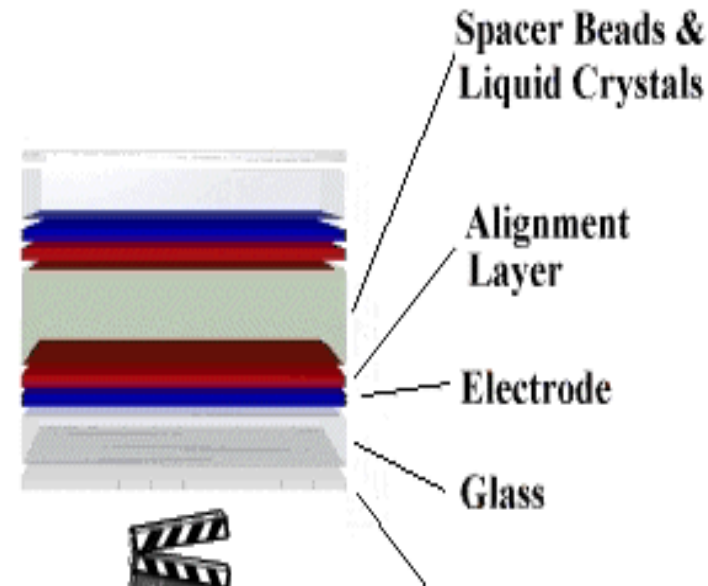



## 3. Operating Principle

### Properties of LCD Display

- Small footprint (approx 1/6 of CRT)
- Light weight (typ. 1/5 of CRT)
- power consumption (typ. 1/4 of CRT)
- Completely flat screen - no geometrical errors
- Crisp pictures - digital and uniform colors
- No electromagnetic emission
- Fully digital signal processing possible
- Large screens (>20 inch) on desktops
- High price (presently 3x CRT)
- Poor viewing angle (typ. 50 degrees)
- Low contrast and luminance (typ. 1:100)
- Low luminance (typ. 200 cd/m<sup>2</sup>)



Maximum luminosity : 50% of CRT as 50% of light is blocked by the upper polarizer.



## 3. Operating Principle

### Advantage of LCD over CRT

- **Smaller size**—AMLCDs occupy approximately percent less space than CRT displays—an important feature when office space is limited.
- **Lower power consumption**—AMLCDs typically consume about half the power and emit much less heat than CRT displays.
- **Lighter weight**—AMLCDs weigh approximately 70 percent less than CRT displays of comparable size.
- **No electromagnetic fields**—AMLCDs do not emit electromagnetic fields and are not susceptible to them. Thus, they are suitable for use in areas where CRTs cannot be used.
- **Longer life**—AMLCDs have a longer useful life than CRTs; however, they may require replacement of the backlight.



Maximum luminosity : 50%  
as 50% of light is blocked by  
the upper polarizer.



# Applications

## A) Thin Film Transistor (TFT)

- Constructed on a glass surface using a photolithographic process.
- The source and gate are the control electrodes. The drain electrode connects to the liquid crystal pixel. The thin layer of amorphous silicon is the semiconducting material that allows the TFT to function. The capacitor is attached to the pixel electrode, but is not an integral part of the TFT.

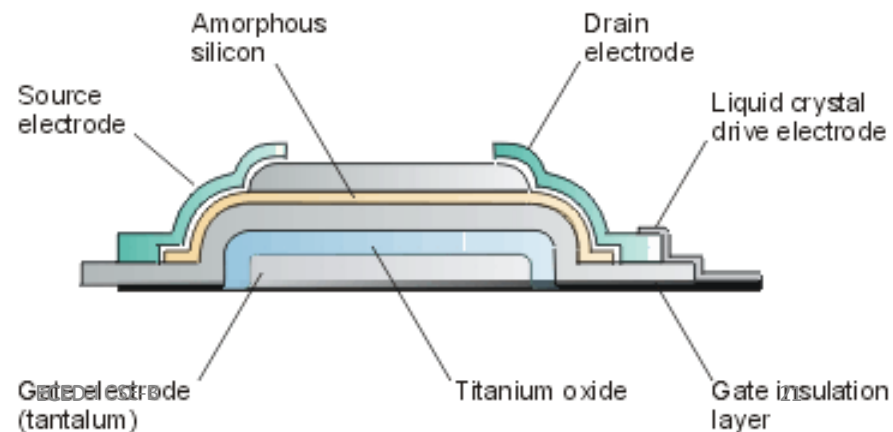
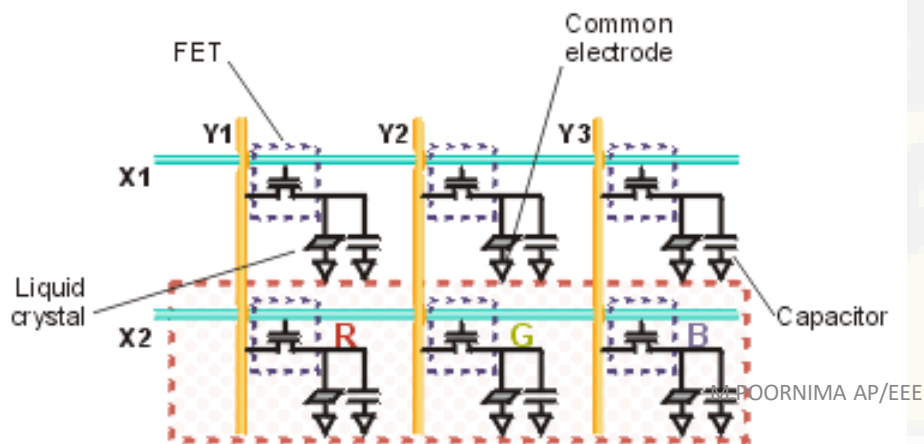



# Applications

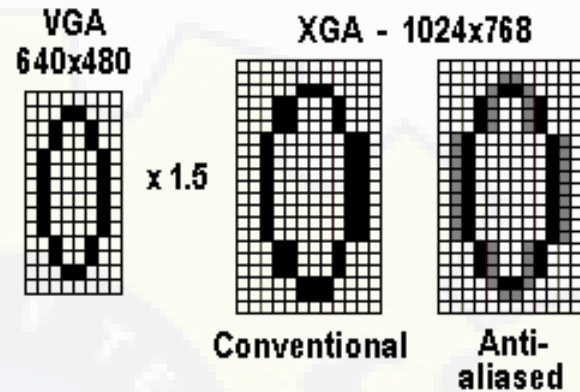

## B) Alpha-numeric display

- Digital letters can be displayed by blocking the lights in different plates we place.
- For applications such as **digital watches** and **calculators**, ***a mirror is used*** under the bottom polarizer. With no voltage applied, ambient light passes through the cell, reflects off the mirror, reverses its path, and re-emerges from the top of the cell, giving it a silvery appearance.
- When the electric field is on, the aligned LC molecules do not affect the polarization of the light. ***The analyzer prevents the incident light from reaching the mirror and no light is reflected***, causing the cell to be ***dark***. When the ***electrodes are shaped in the form of segments of numbers and letters*** they can be turned on and off to form an alpha-numeric display.



# Applications

## C) Back lighting systems

- Alpha-numeric displays are not very bright because the **light must pass through multiple polarizers** which **severely cut down on the intensity of the light**, in addition to the various layers of the display which are only semi-transparent. Therefore a **more intense source** is employed in the form of a **back lighting system**.

### For brighter displays

- Light bulbs mounted behind
- At the edges of the display replace the reflected ambient light.
- **Disadvantage** : very power intensive. Back lighting systems are used in more complex displays such as **laptop computer screens, monitors, LCD projectors, pda, digital devices such as digital camera and DV.**