



SNS COLLEGE OF TECHNOLOGY

Coimbatore-35
An Autonomous Institution

Accredited by NBA – AICTE and Accredited by NAAC – UGC with 'A+' Grade
Approved by AICTE, New Delhi & Affiliated to Anna University, Chennai

DEPARTMENT OF MECHATRONICS

19MCB302 – INDUSTRIAL ELECTRONICS & APPLICATION III YEAR V SEM

UNIT 1 – INTRODUCTION TO POWER ELECTRONICS

TOPIC – SCR

Mr. M.Anand., M.E.,(Ph.D.,)

ASSISTANT PROFESSOR,

DEPARTMENT OF MECHATRONICS,

SNSCT, Coimbatore.





Revision



Differentiate Power Electronics Switch and Solid state switch.

Why Power Electronics Switch?

4 Type of Conversion process.





SCR

The Silicon Controlled Rectifier (SCR) is the most important and mostly used member of the thyristor family. SCR can be used for different applications like rectification, regulation of power and inversion, etc. Like a diode, SCR is a unidirectional device that allows the current in one direction and opposes in another direction.

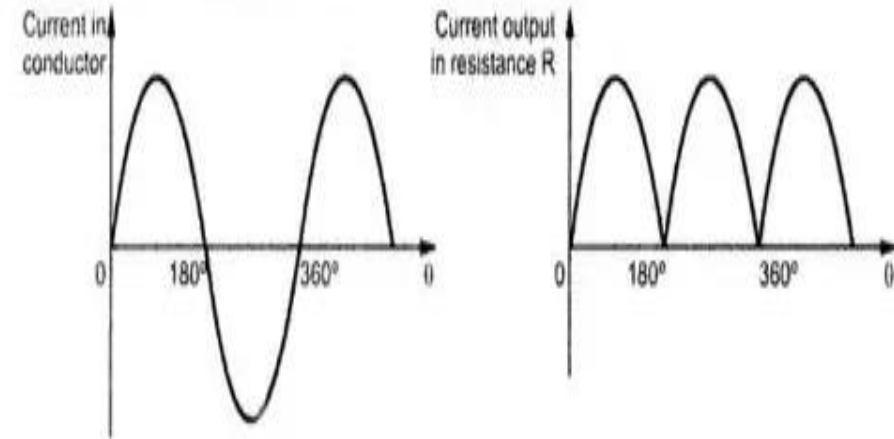
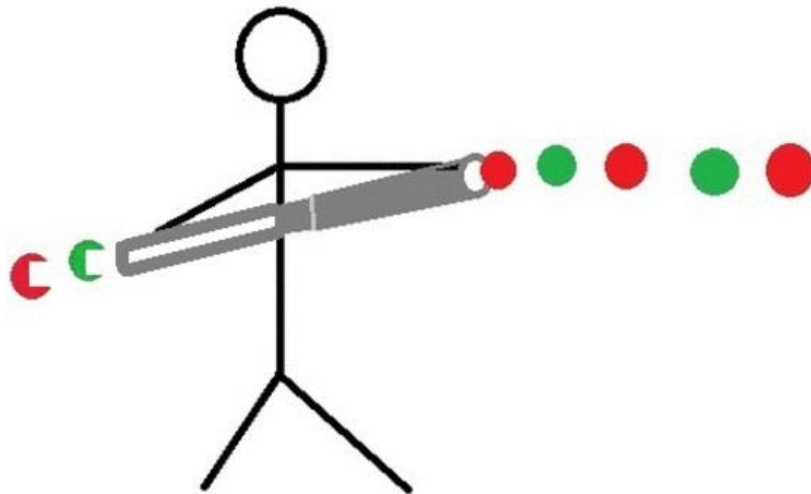



SYMBOL

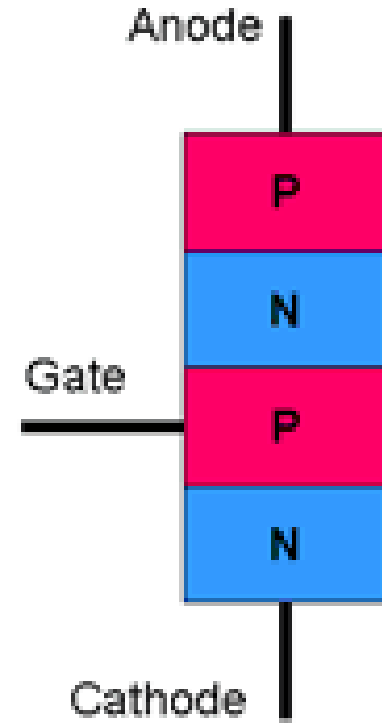
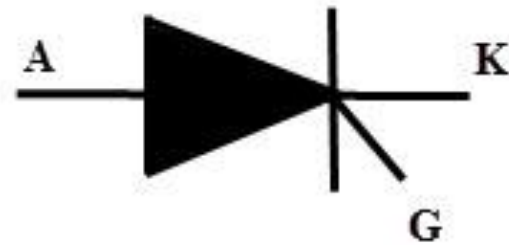
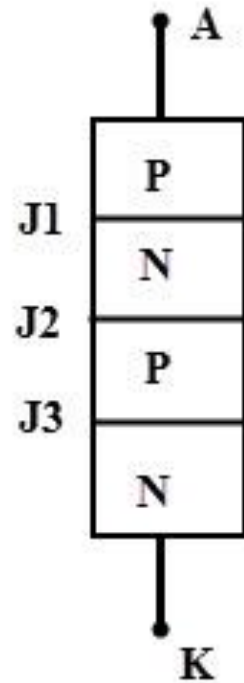



LAYER

1

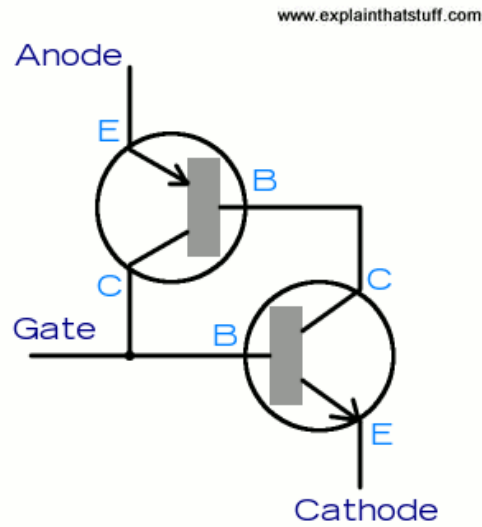

www.explainthatstuff.com

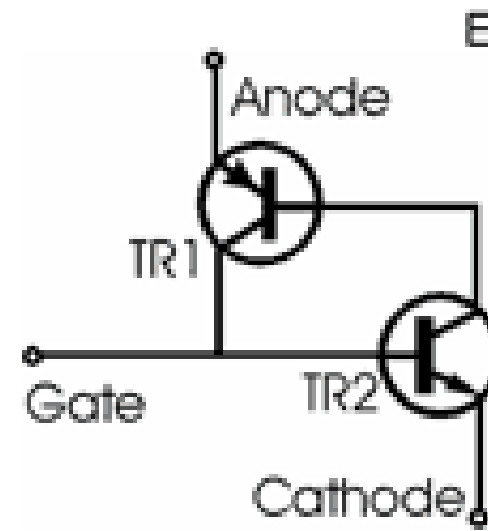
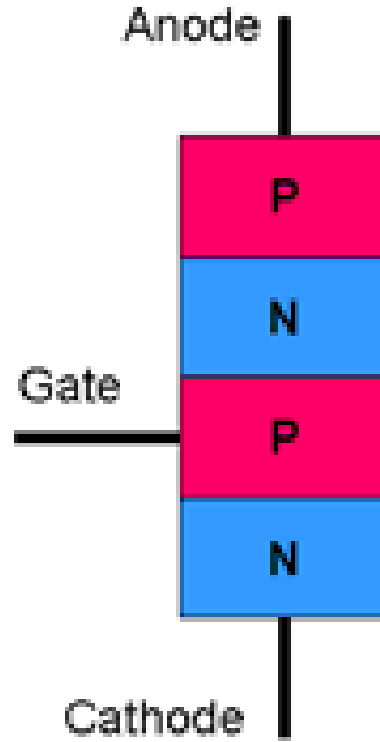

Equivalent circuits

Thyristor

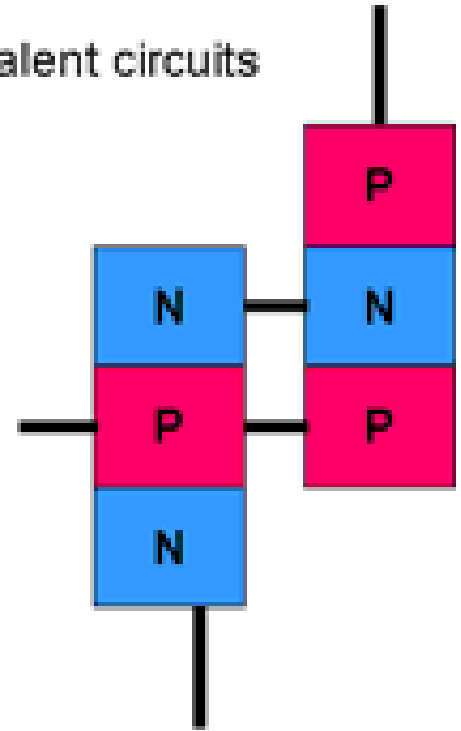



CIRCUIT DIAGRAM

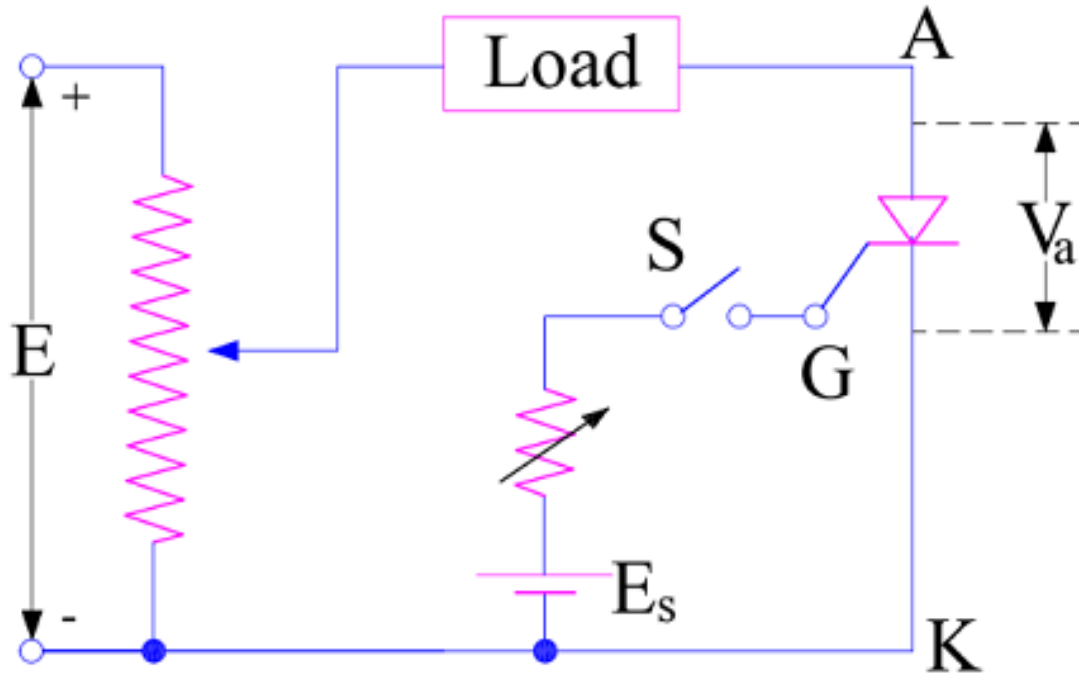

<https://www.youtube.com/watch?v=xefULD5GEpo>



How SCR works:

Forward Blocking mode



Reverse Blocking mode



Forward Conduction mode

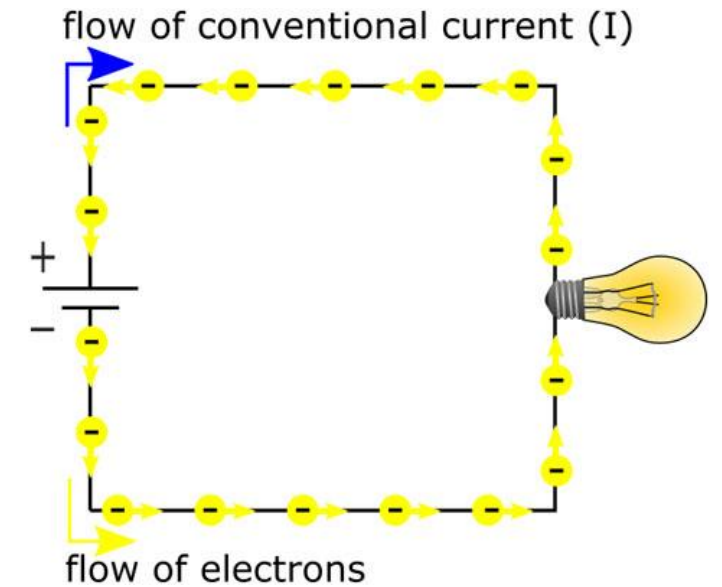

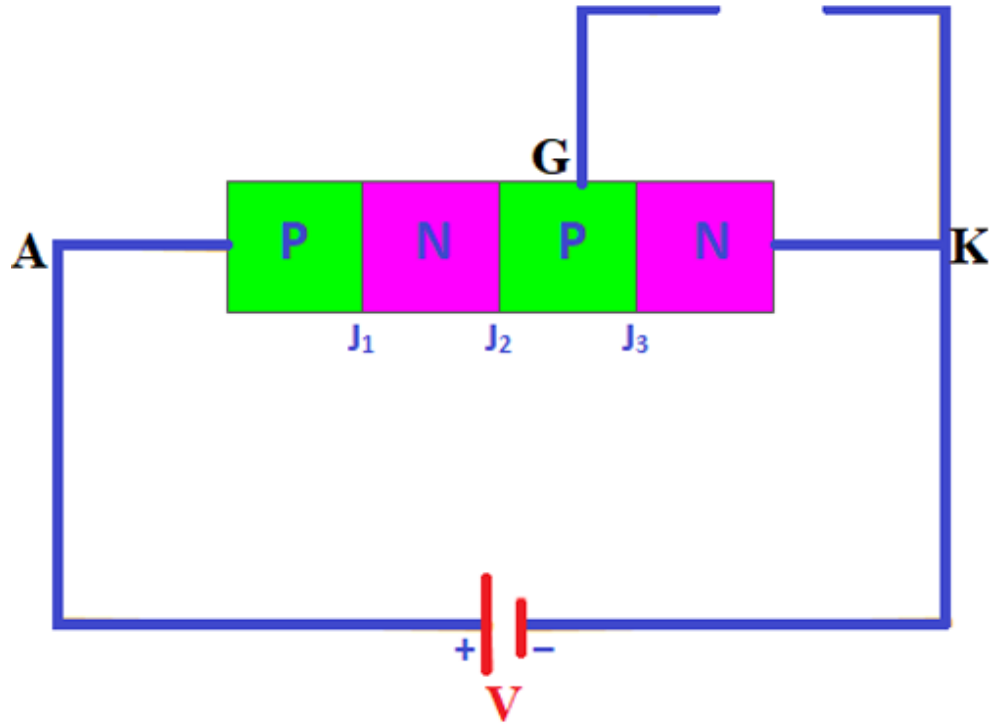

Forward Blocking Mode of SCR

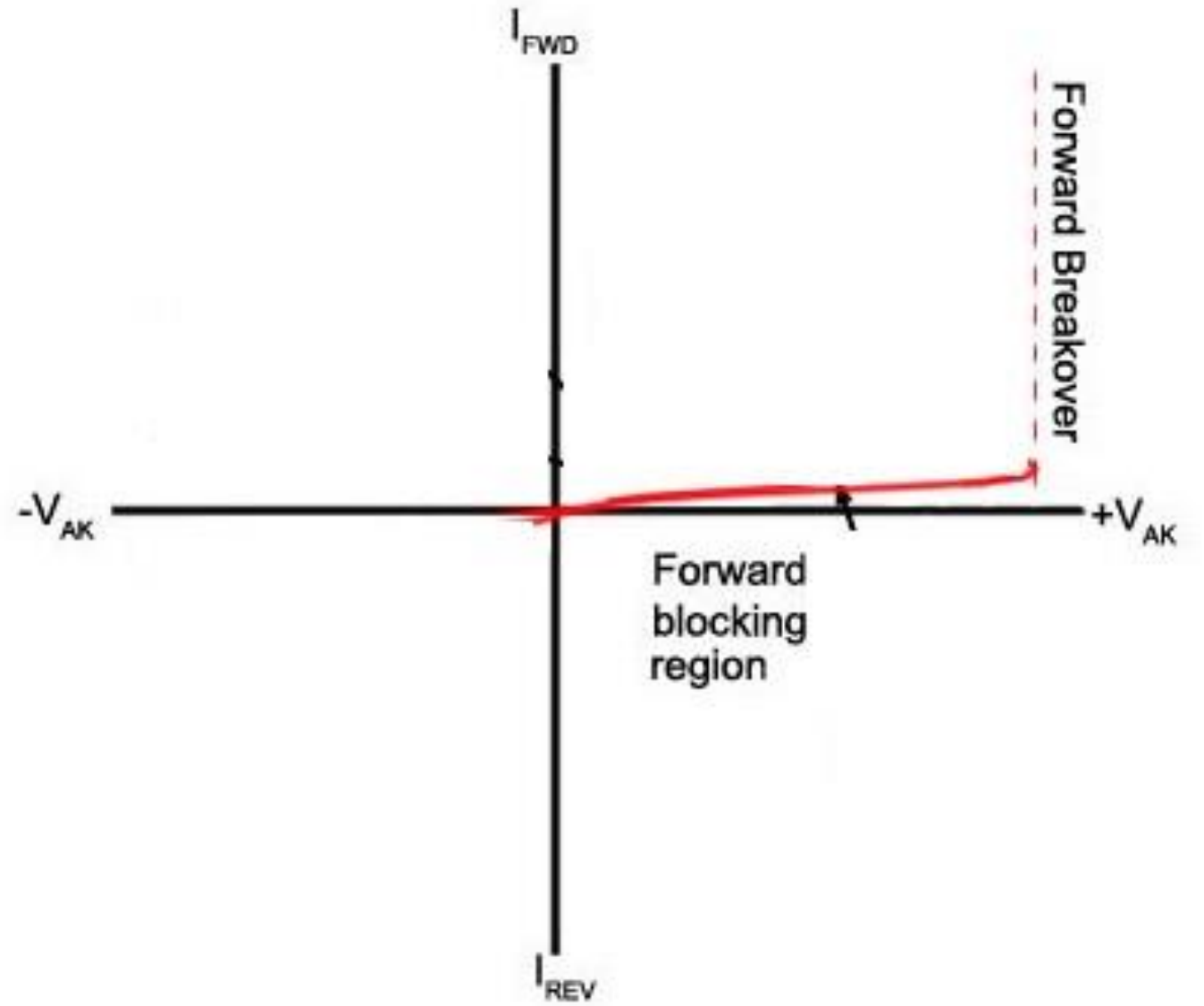

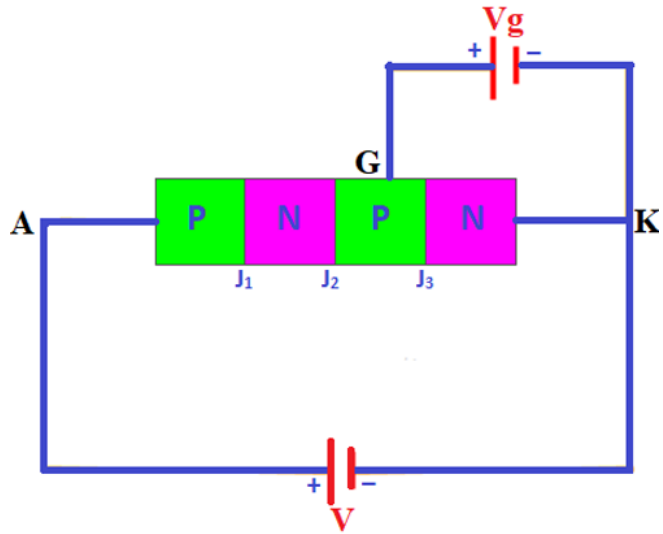

Forward Conducting Mode of SCR

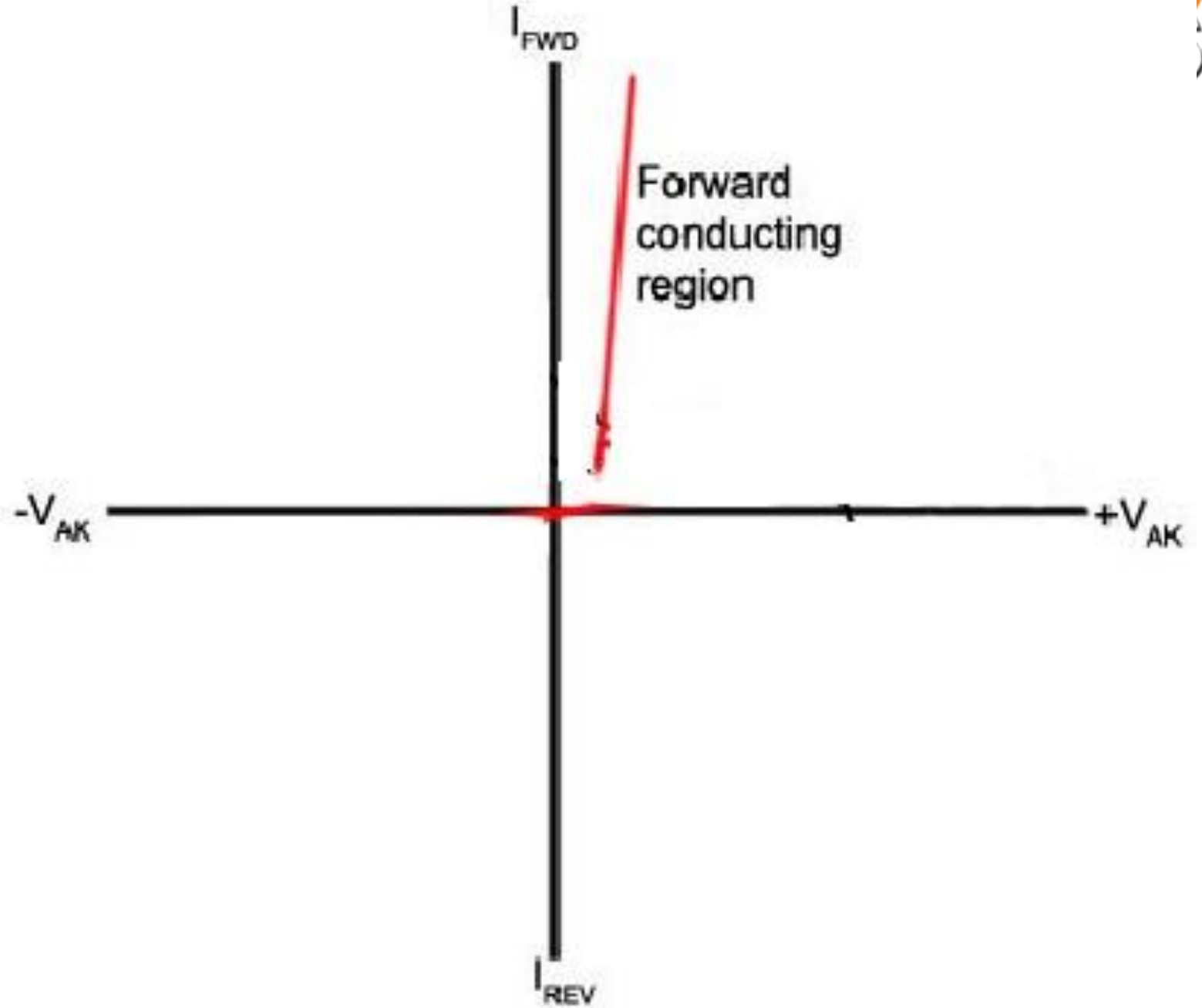

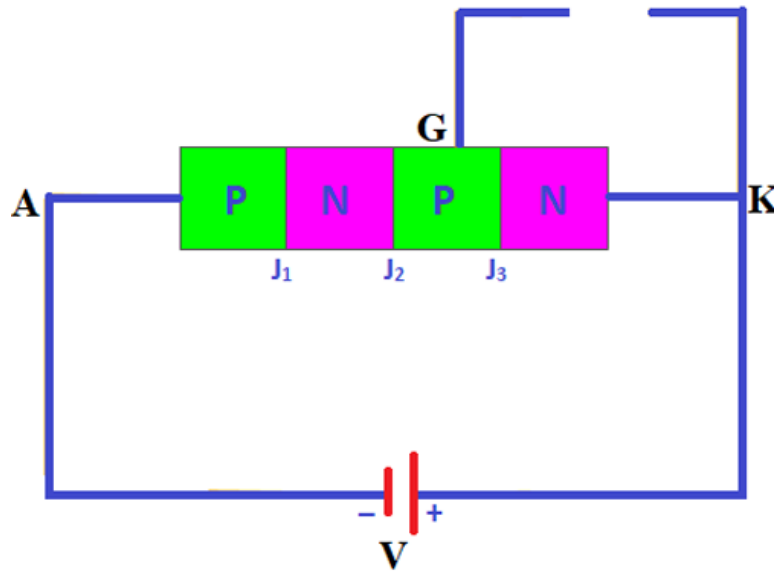

Reverse Blocking Mode of SCR

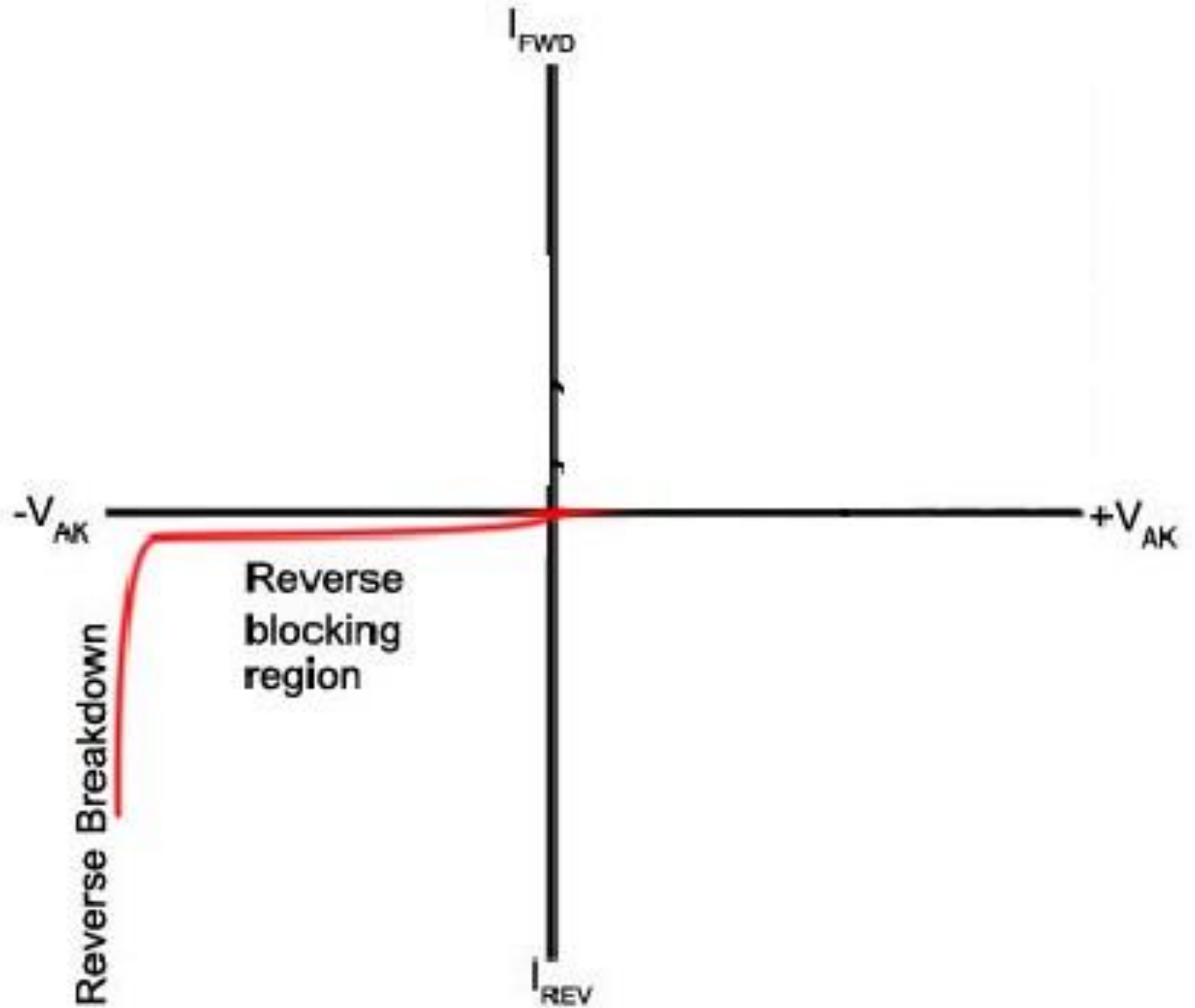



Thyristor Operating modes

Thyristors have three modes :

- **Forward blocking mode:** Only leakage current flows, so thyristor is not conducting.
- **Forward conducting mode:** large forward current flows through the thyristor.
- **Reverse blocking mode:** When cathode voltage is increased to reverse breakdown voltage, Avalanche breakdown occurs and large current flows.

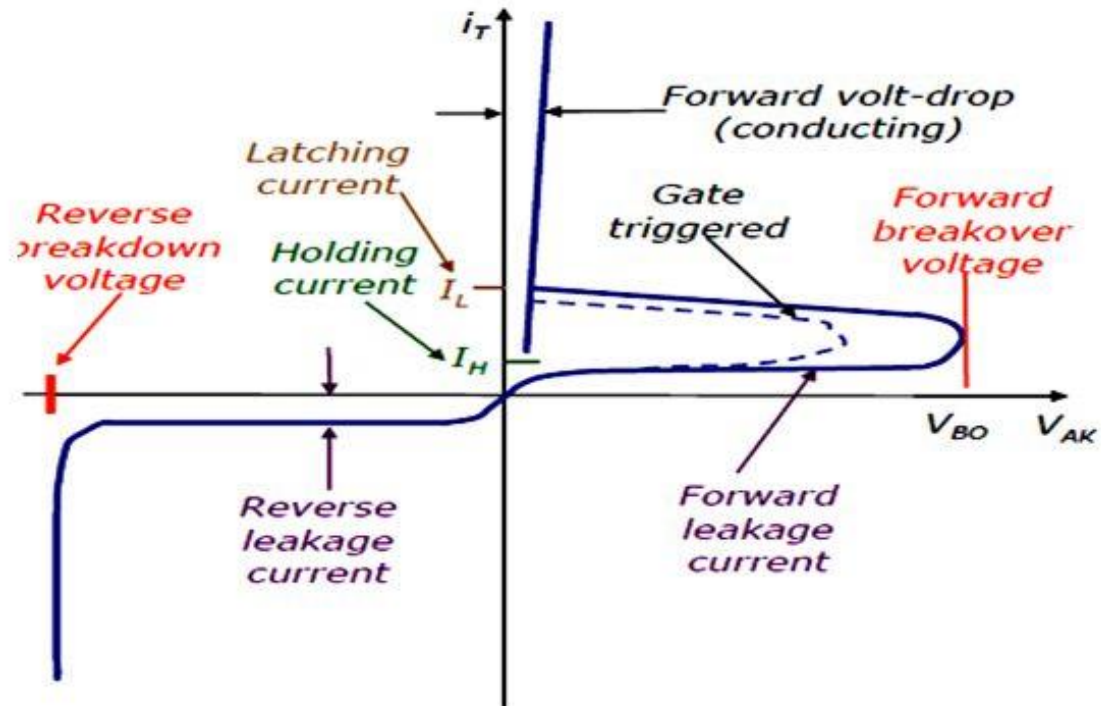



Advantages of Silicon Controlled Rectifier

- ✓ As compared with electromechanical or mechanical switch, SCR has no moving parts. Hence, with a high efficiency it can deliver noiseless operation.
- ✓ The switching speed is very high as it can perform 1 nano operations per second.
- ✓ These can be operated at high voltage and current ratings with a small gate current.
- ✓ More suitable for AC operations because at every zero position of the AC cycle the SCR will automatically switch OFF.
- ✓ Small in size, hence easy to mount and trouble free service.



Application





ASSESSMENT

Find the Difference and justify it.

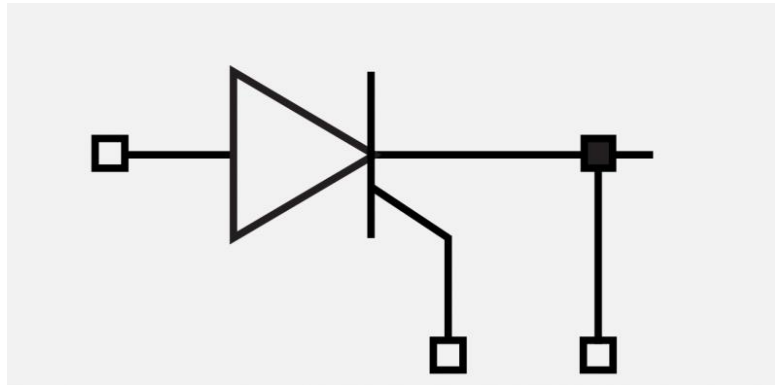

A

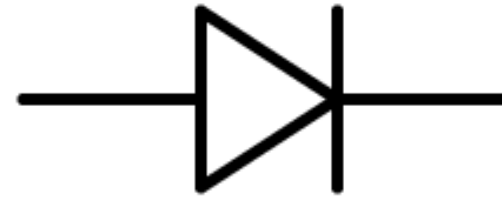

B





References

1. <https://components101.com/articles/scr-introduction-working-and-applications-in-power-electronics>
2. <https://www.electrical4u.com/thyristor-silicon-controlled-rectifier-scr/>
3. <https://www.allaboutcircuits.com/textbook/semiconductors/chpt-7/silicon-controlled-rectifier-scr/>
4. https://www.youtube.com/watch?v=9h7_vDUE908
5. https://www.youtube.com/watch?v=npRk_P5A5cs

