

Dr.SNS RAJALAKSHMI COLLEGE OF ARTS AND SCIENCE  
(Autonomous)  
Accredited by NAAC - UGC with 'A+ Grade (Cycle IV)  
(Recognised by UGC, Approved by AICTE & Affiliated to Bharathiar University)  
Coimbatore- 49



**DEPARTMENT OF COMMERCE WITH INFORMATION  
TECHNOLOGY**

**21UCI507 -Business Information Technology**  
**Memory Units**

**Mrs.M.Viveka, MCA., M.Phil., (Ph.D).,**  
**Assistant Professor,**

**Department of Commerce with Information Technology**

# Memory Units



- ✓ Memory means storage of data and the program.
- ✓ Both data and programs are stored in the binary form.
- ✓ The binary system has only two values 0 and 1. These are called bits.
- ✓ A bit is an acronym for binary digit, which stands for one binary piece of information. This can be either 0 or 1.
- ✓ Memory unit is made up of several small storage locations called cells. Each of these cells can store a fixed number of bits called word length.
- ✓ Each cell has a unique number assigned to it called the address of the cell and it is used to identify the cells.
- ✓ The address starts at 0 and goes up to (N-1).

# Memory Units

Memory sizes(Capacity): The size of memory is termed in terms KB,MB,GB etc.,

- ✓ 1 Byte = 8 bits
- ✓ 1 Kilo Byte(KB) = 1024 Bytes(2<sup>10</sup>)
- ✓ 1 Mega Byte(MB) = 1024 KB
- ✓ 1 Giga Byte(GB) = 1024 MB
- ✓ 1 Tera Byte(TB) = 1024 GB
- ✓ 1 Peta Byte(PB) = 1024 TB
- ✓ 1 Exa Byte(EB) = 1024 PB
- ✓ 1 Zetta Byte(ZB) = 1024 EB
- ✓ 1 Yotta Byte(YB) = 1024 ZB

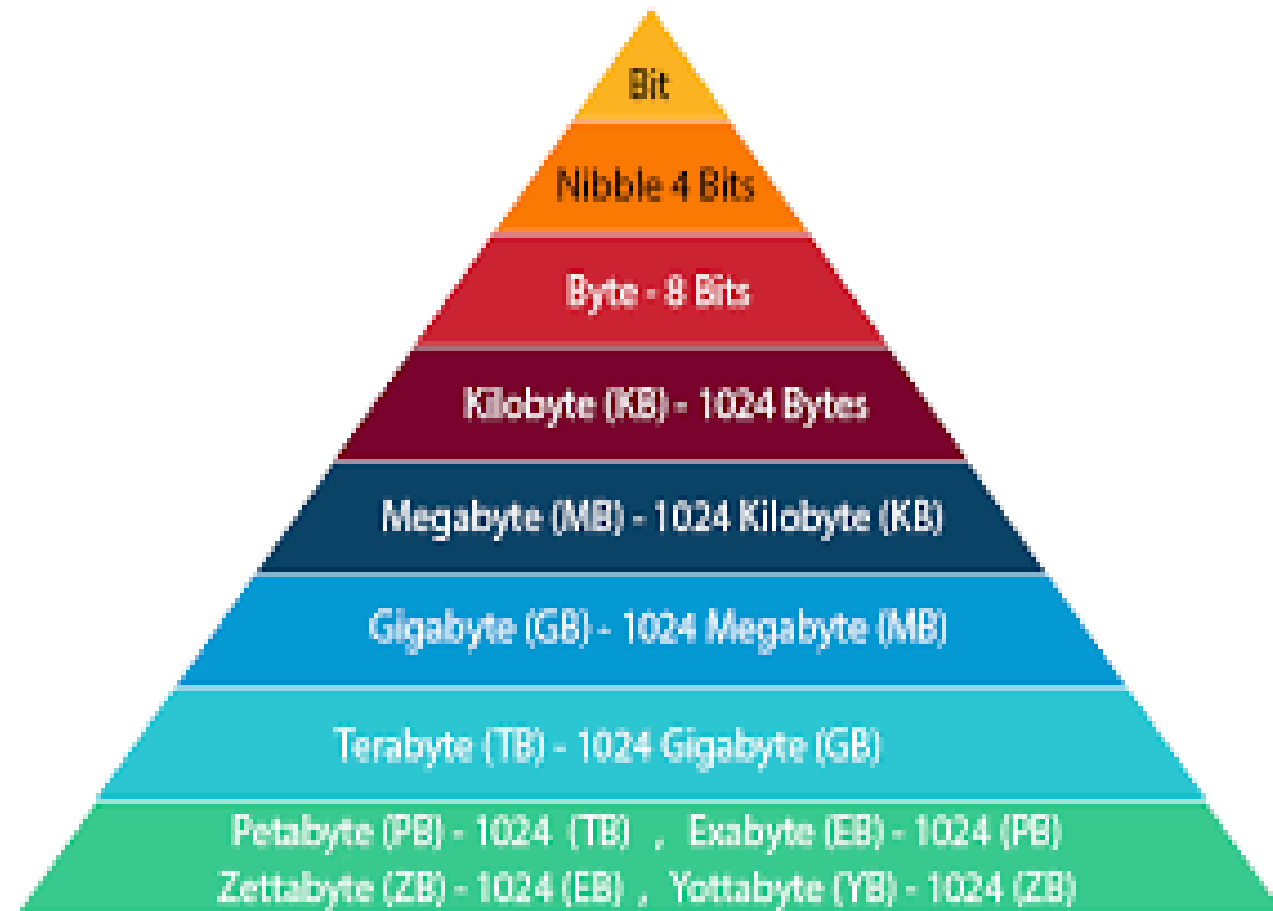

## Primary Memory

- ✓ Known as internal memory or main memory.
- ✓ Qs soon as the computer is switched off, the contents of the primary memory is lost.
- ✓ Primary memory is more expensive than secondary memory. When the computer is doing any job, the data that have to be processed are stored in the primary memory.
- ✓ This data may come from an input device like keyboard or from a secondary storage device like a floppy disk, memory card or pen drive etc.,

# Memory Units

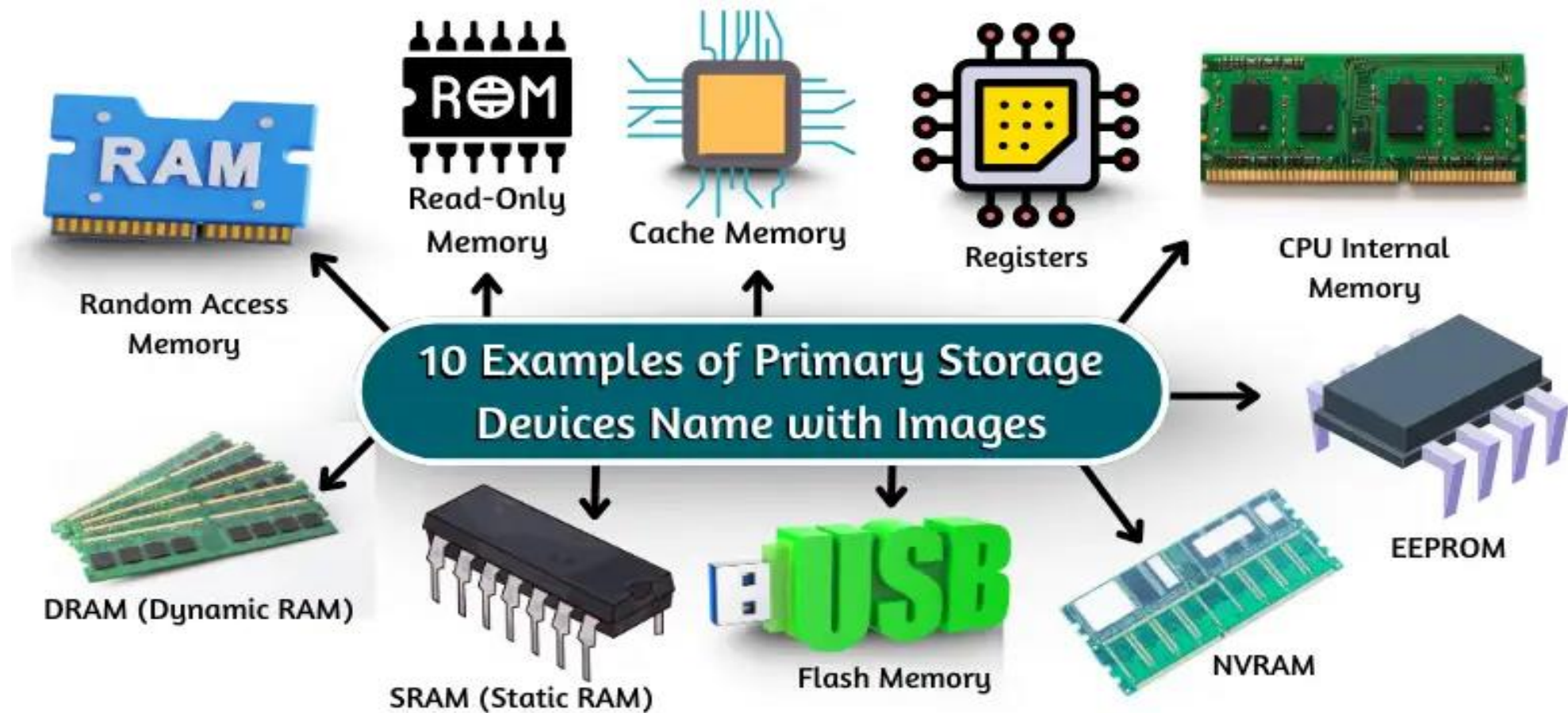

# Memory Units

## How does Computer Memory Works ?

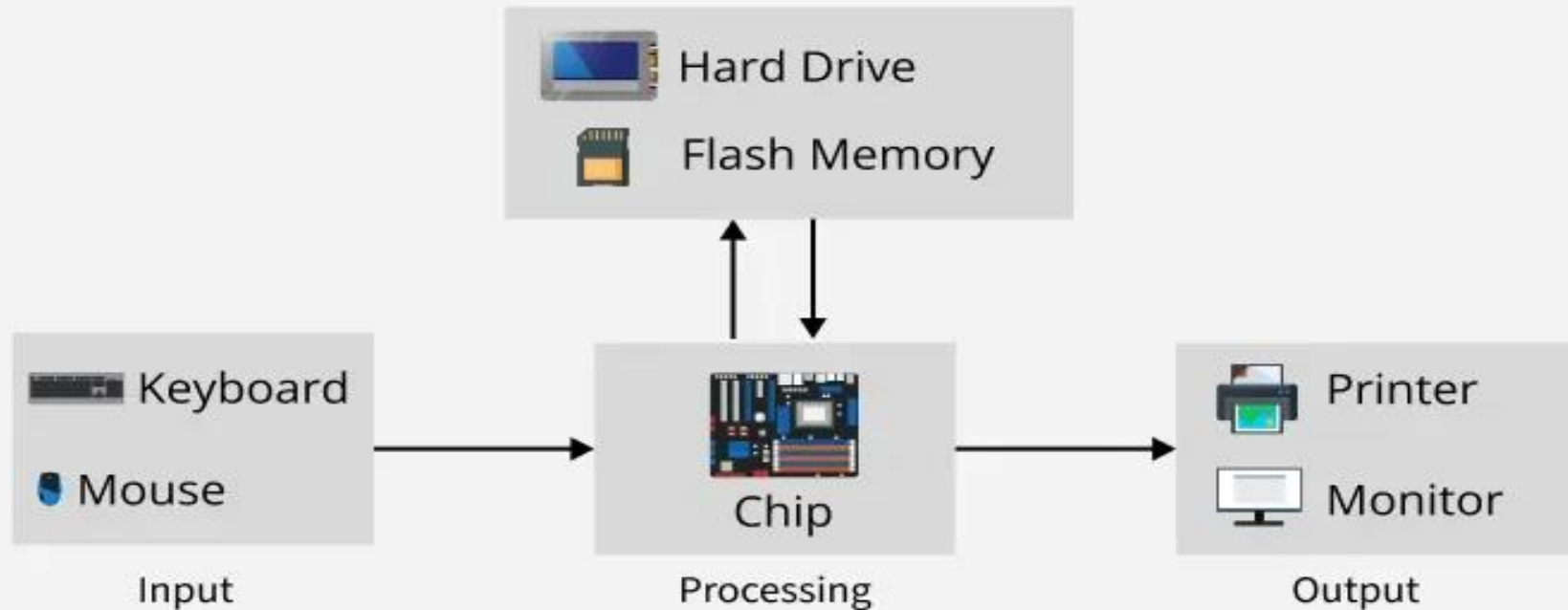

# Memory Units-RAM

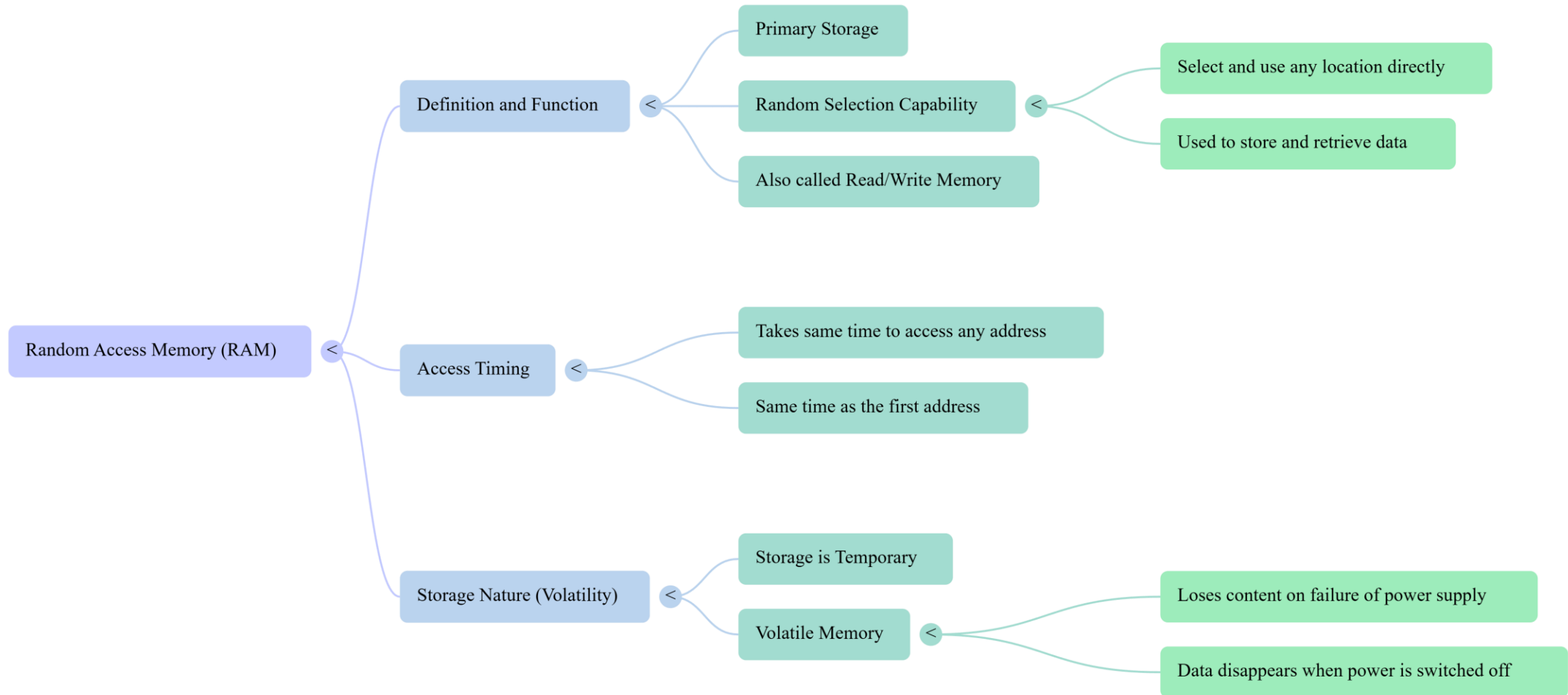

# Memory Units-ROM

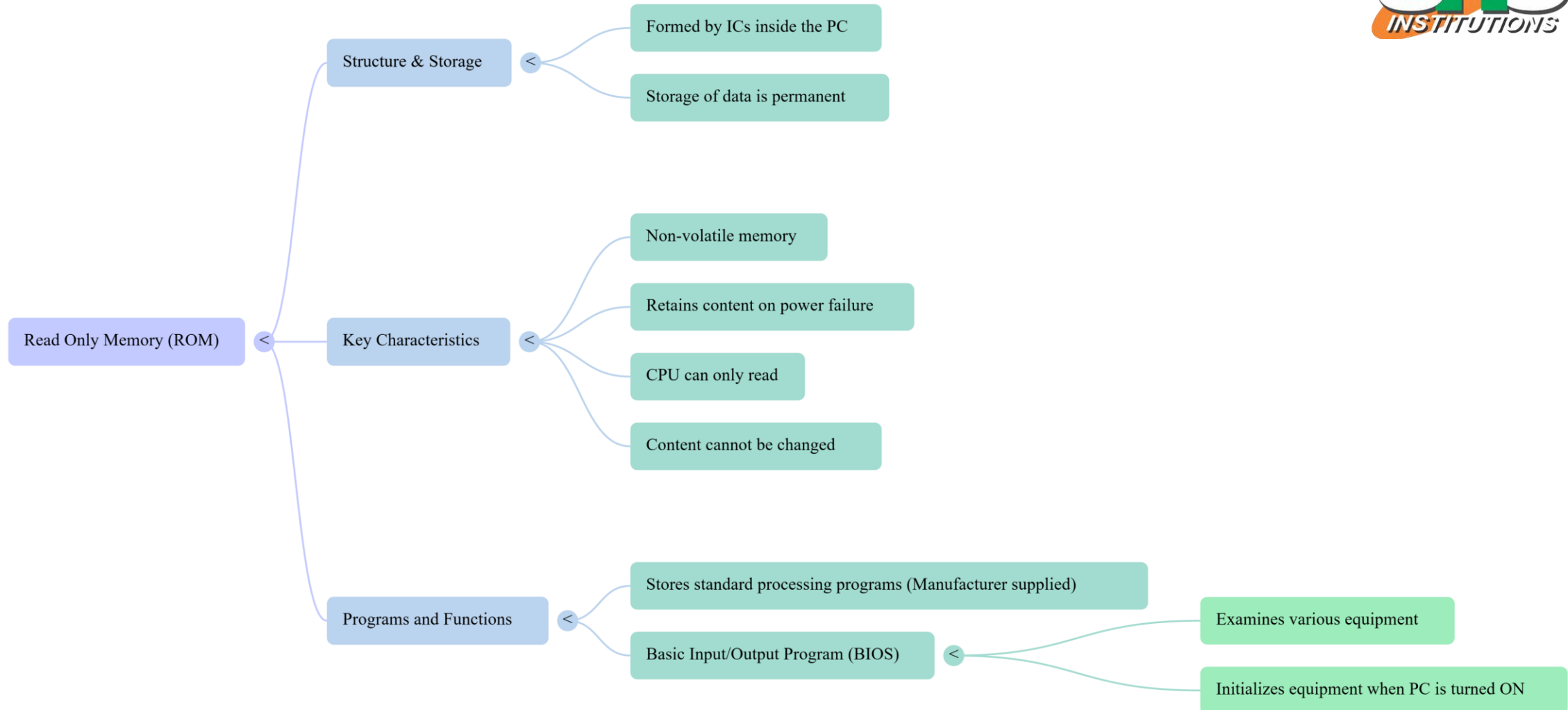

# Memory Units

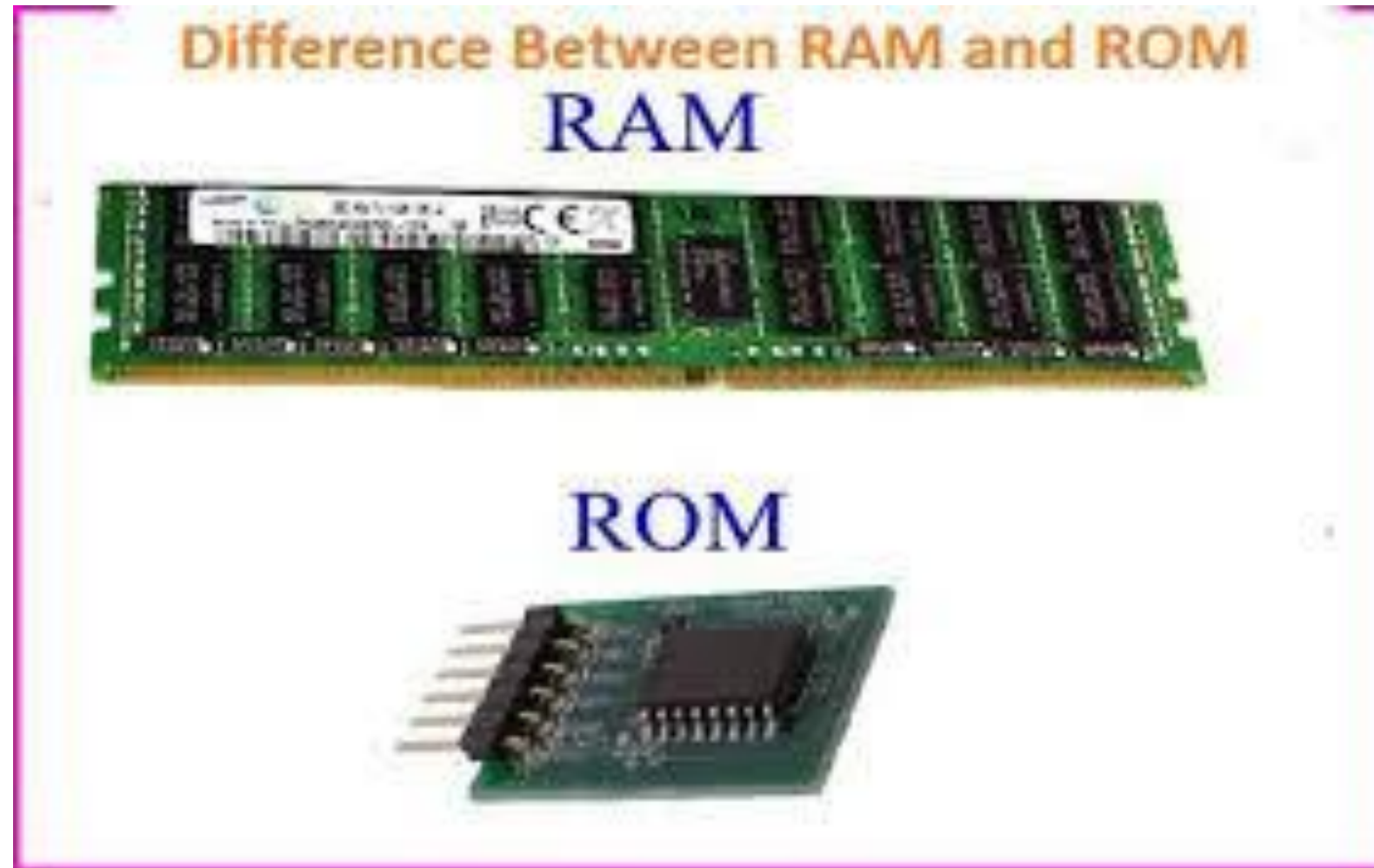

## PROM :

- ✓ Another type of primary memory in computer - Programmable Read Only Memory (PROM).
- ✓ It is not possible to modify or erase programs stored in ROM, but it is possible for you to store your program in PROM chip.
- ✓ Once the programs are written it cannot be changed and remain intact even if power is switched off.
- ✓ Therefore, programs or instructions written in PROM or ROM cannot be erased or changed.

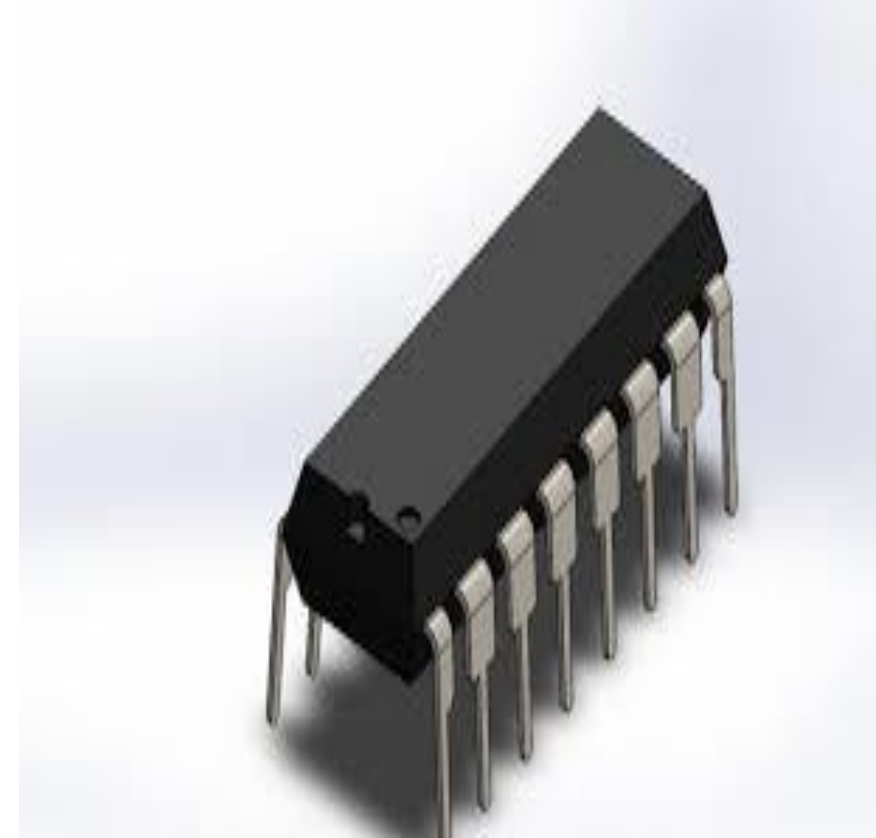

- ✓ Erasable Programmable Read Only Memory, which overcome the problem of PROM and ROM.
- ✓ EPROM chip can be programmed time and again by erasing the information stored earlier in it.
- ✓ Information can be erased by exposing it to ultraviolet light.
- ✓ Memory can be reprogrammed using a special programming facility. When the EPROM is in use, information can only be read



## **EAPROM :**

- ✓ This stands for Electrically Alterable Programmable Read Only Memory.
- ✓ The only difference is that the memory can be altered using electrical signals. The whole of the memory need not be erased.

## **Registers :**

- ✓ The CPU processes data and instruction with high speed.
- ✓ Movement of data between various units of the computer.
- ✓ Transfer the processed data with high speed & uses a number of special memory units.
- ✓ They are not part of the main memory but they store data or information temporarily and pass it on as directed by the control unit

## CACHE MEMORY

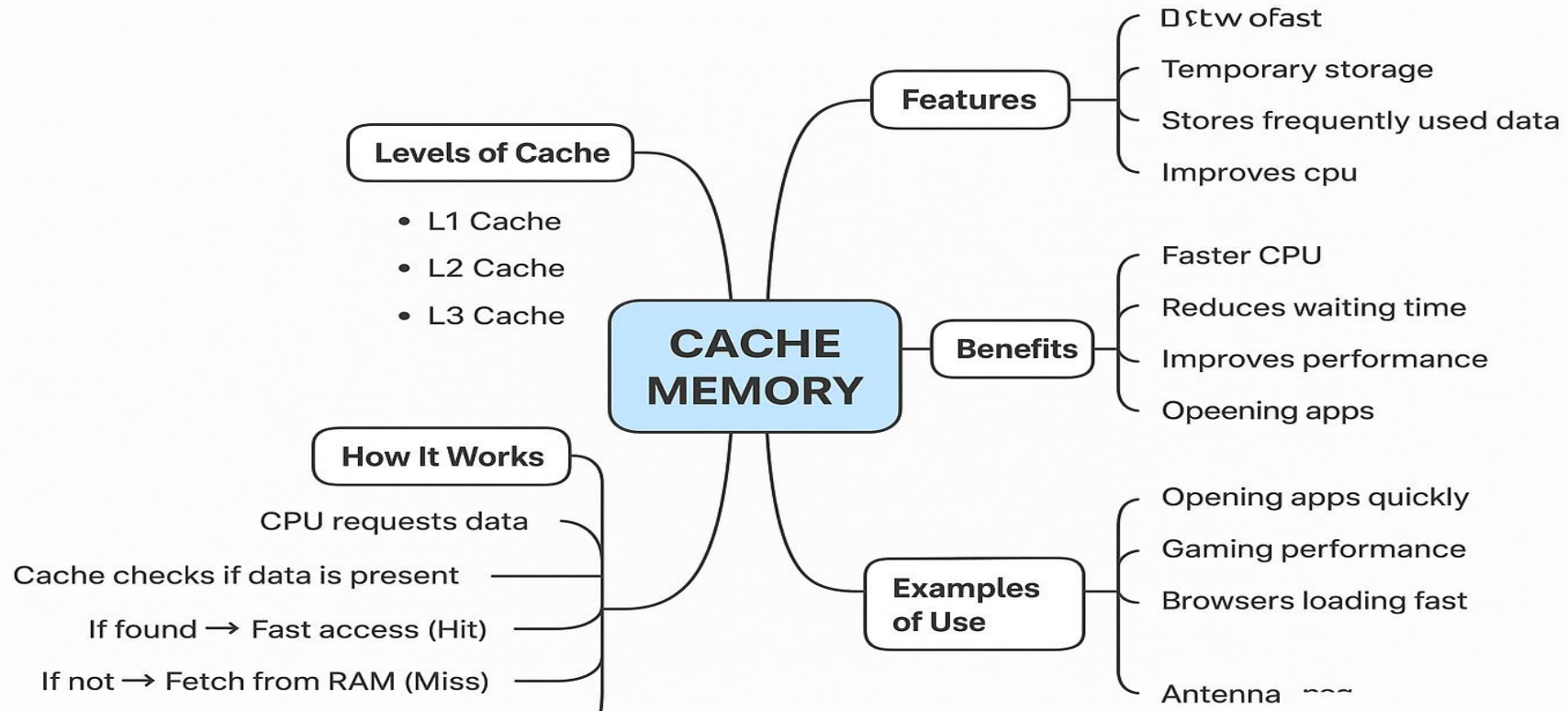

## How does Microsoft optimize auxiliary storage devices in Azure cloud platforms? (Microsoft, 2025 )

Microsoft Azure is one of the world's leading cloud platforms that provides storage for huge volumes of data. In Azure, **auxiliary storage devices** refer to secondary storage like Hard Disk Drives (HDD), Solid State Drives (SSD), and Azure Storage services used to store data permanently.

To ensure high performance, speed, and cost efficiency, Microsoft uses advanced techniques to optimize how these storage devices work in the cloud.

## 2. Problem Scenario

A global e-commerce company uses Azure to store:

Customer data

Product images

Transaction records

Backup files

The company faced issues such as:

Slow data access

High storage costs

Delays during peak hours

Risk of data loss

Microsoft Azure optimized auxiliary storage to solve these issues.

## Workflow of Optimization in Azure

- Data is analyzed for access frequency
- System assigns suitable storage tier
- Frequently used data is cached
- Data is replicated for safety
- Load is evenly distributed
- Performance continuously monitored and optimized

## Results Achieved After optimization:

- 40% reduction in storage cost
- 60% improvement in data access speed
- High reliability and zero data loss
- Better user experience
- Efficient cloud resource usage

**Next Topic:**  
**Auxiliary Storage Devices**

