

SNS COLLEGE OF TECHNOLOGY



(An Autonomous Institution)

Approved by AICTE, New Delhi, Affiliated to Anna University, Chennai

Accredited by NAAC-UGC with 'A++' Grade (Cycle III) &

Accredited by NBA (B.E - CSE, EEE, ECE, Mech & B.Tech.IT)

COIMBATORE-641 035, TAMIL NADU

DEPARTMENT OF ELECTRONICS AND COMMUNICATION ENGINEERING

Course Name: 23ECT203 LINEAR INTEGRATED CIRCUITS

II YEAR/VI SEMESTER

UNIT III –ANALOG MULTIPLIER AND PLLR

Topic : Analog Multiplier IC

The Signal Interaction Challenge

Telecommunications

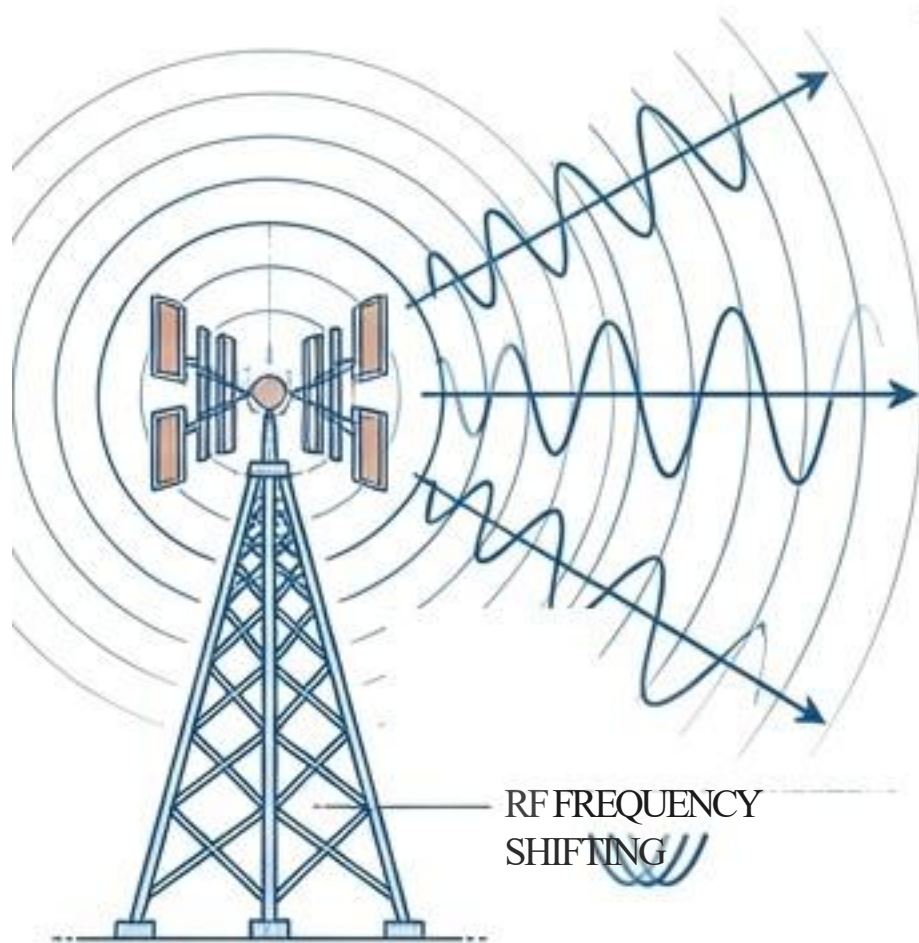

Need: Frequency shifting for transmission.

Instrumentation

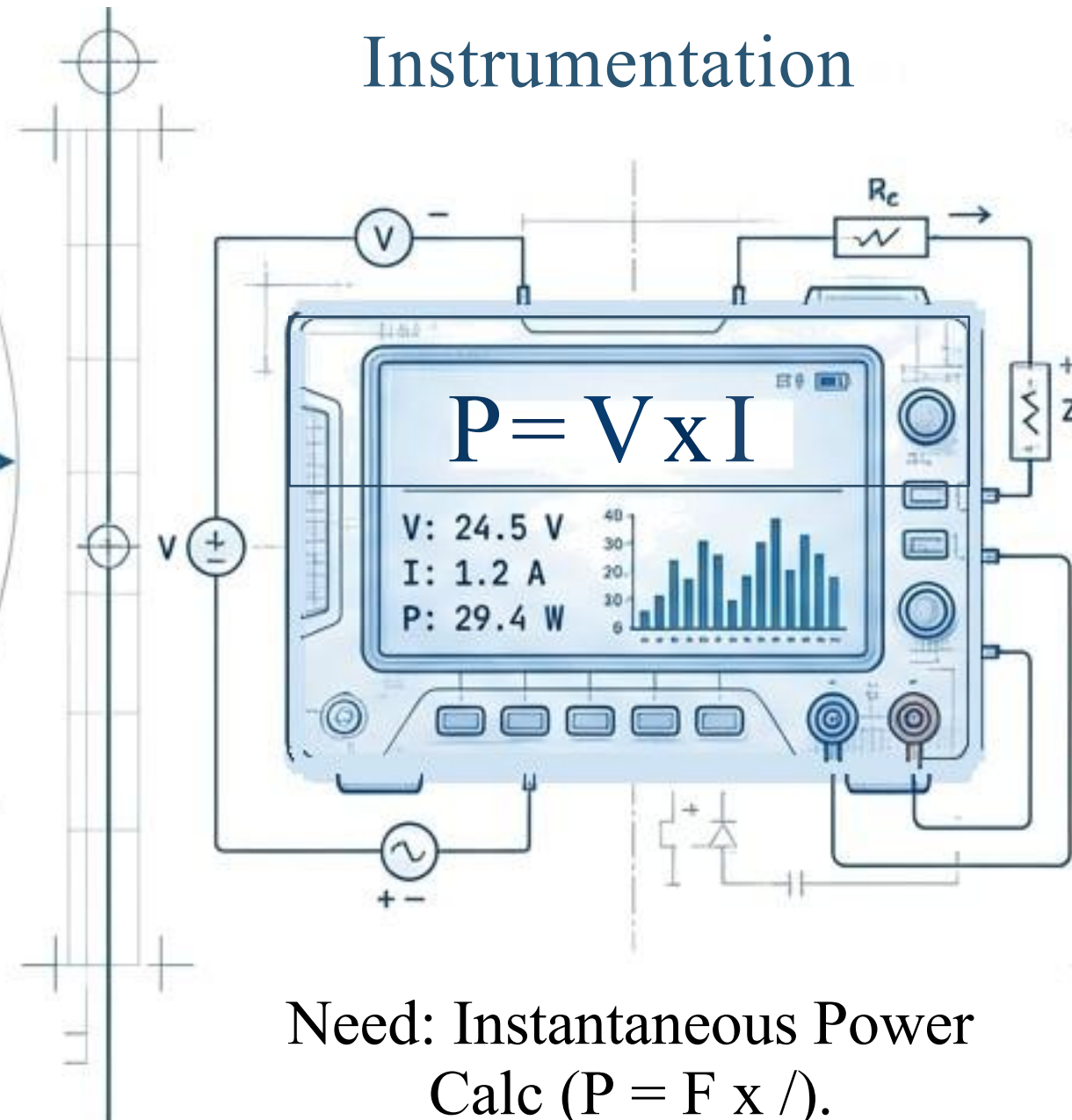

Need: Instantaneous Power Calc ($P = V \times I$).

Signal Processing

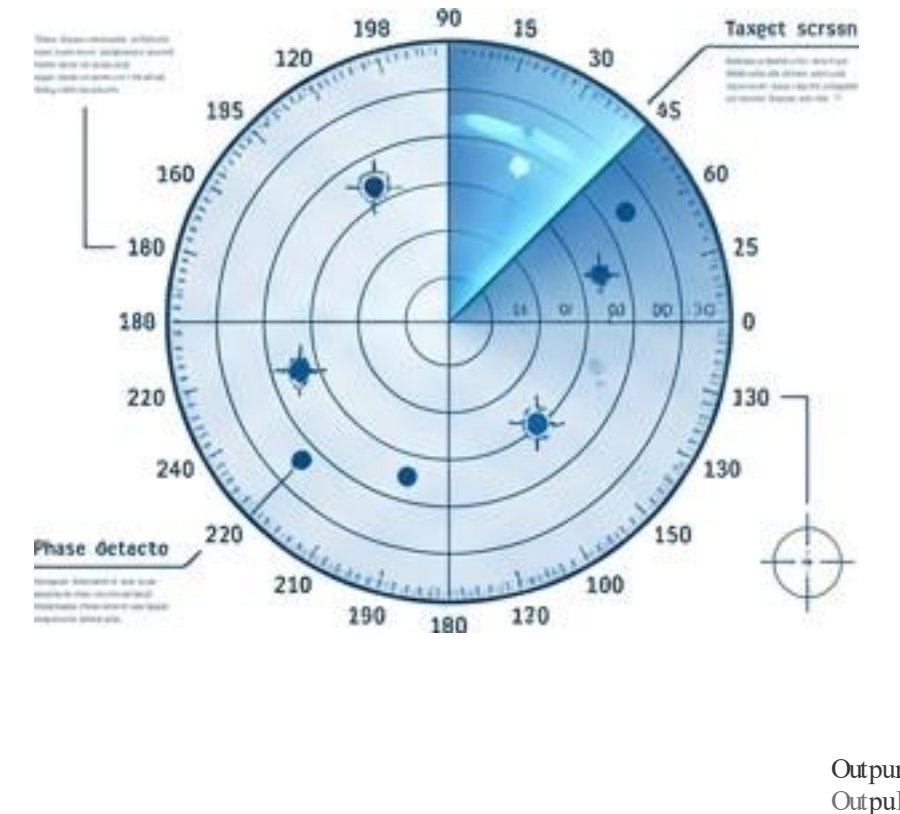

Need: Phase difference detection.

The Core Insight: Linear circuits cannot allow one voltage to dynamically control the gain of another. **we need a multiplier.**

Defining the Ideal Multiplier

$$V_{out} = \frac{\quad}{K}$$

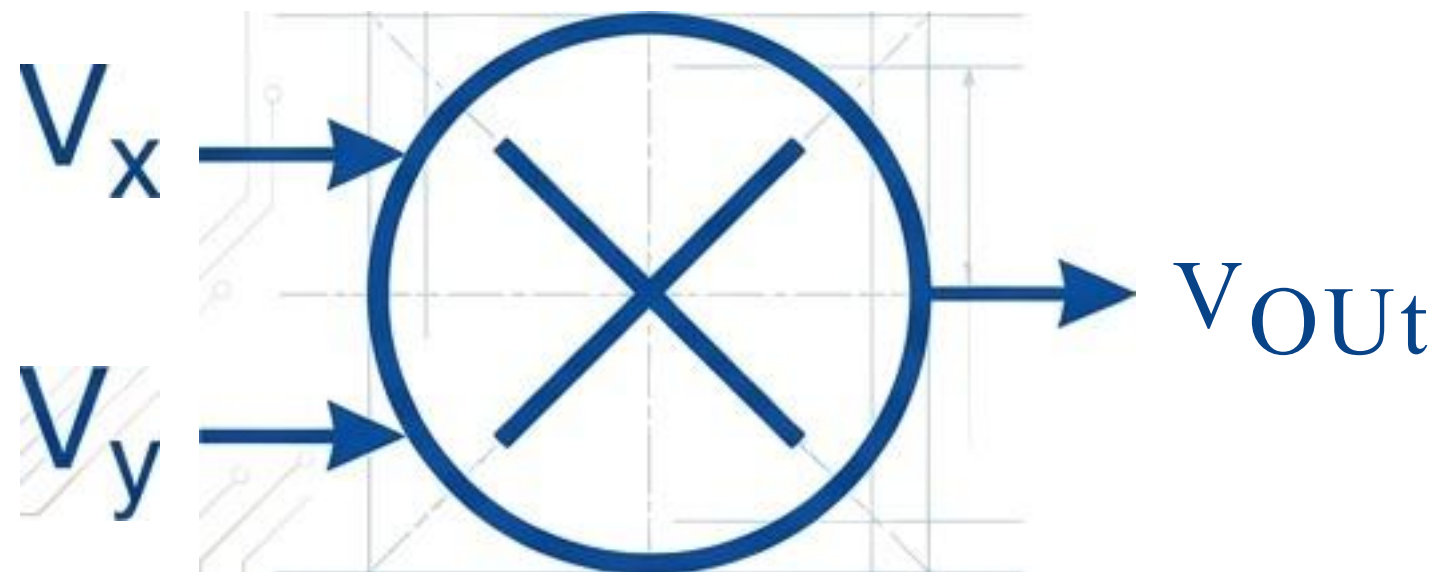

Design Specs

- Linearity: Output w Product of Inputs
- Operation: 4-Quadrant (Positive & Negative Polarity)
- Scale Factor (K): Typically 10V

PHASE 3: IDEATE

Exploring the Solution Space

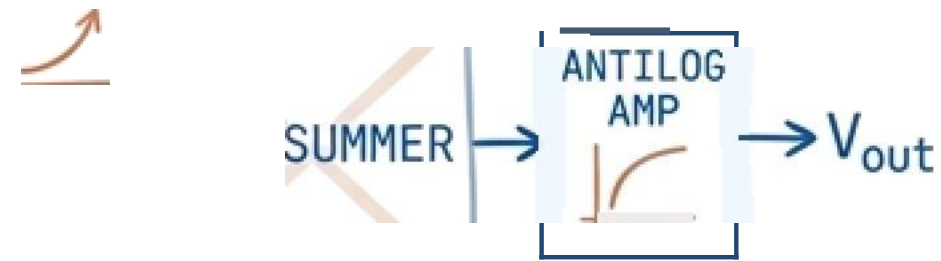

$$(A+B)^2 - (A-B)^2$$

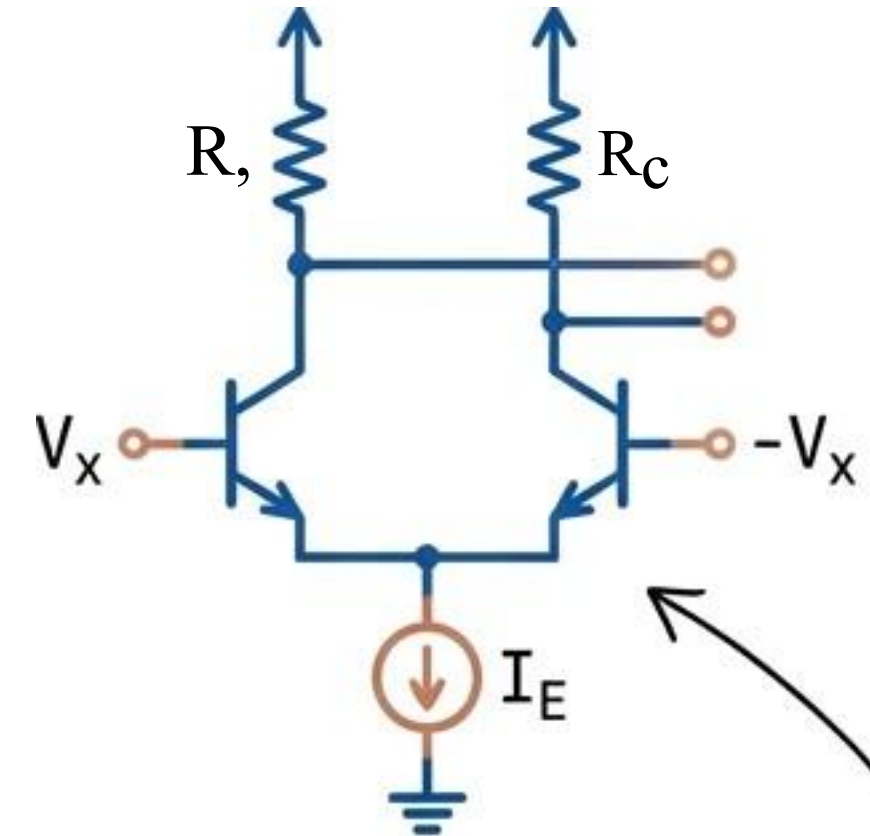

Too Slow /
Bandwidth Limited

Complex & Bulky

THE INNER: Variable
Transconductance

Utilizes transistor emitter current
dependence. High speed. Integratable.

The Gilbert Multiplier Cell

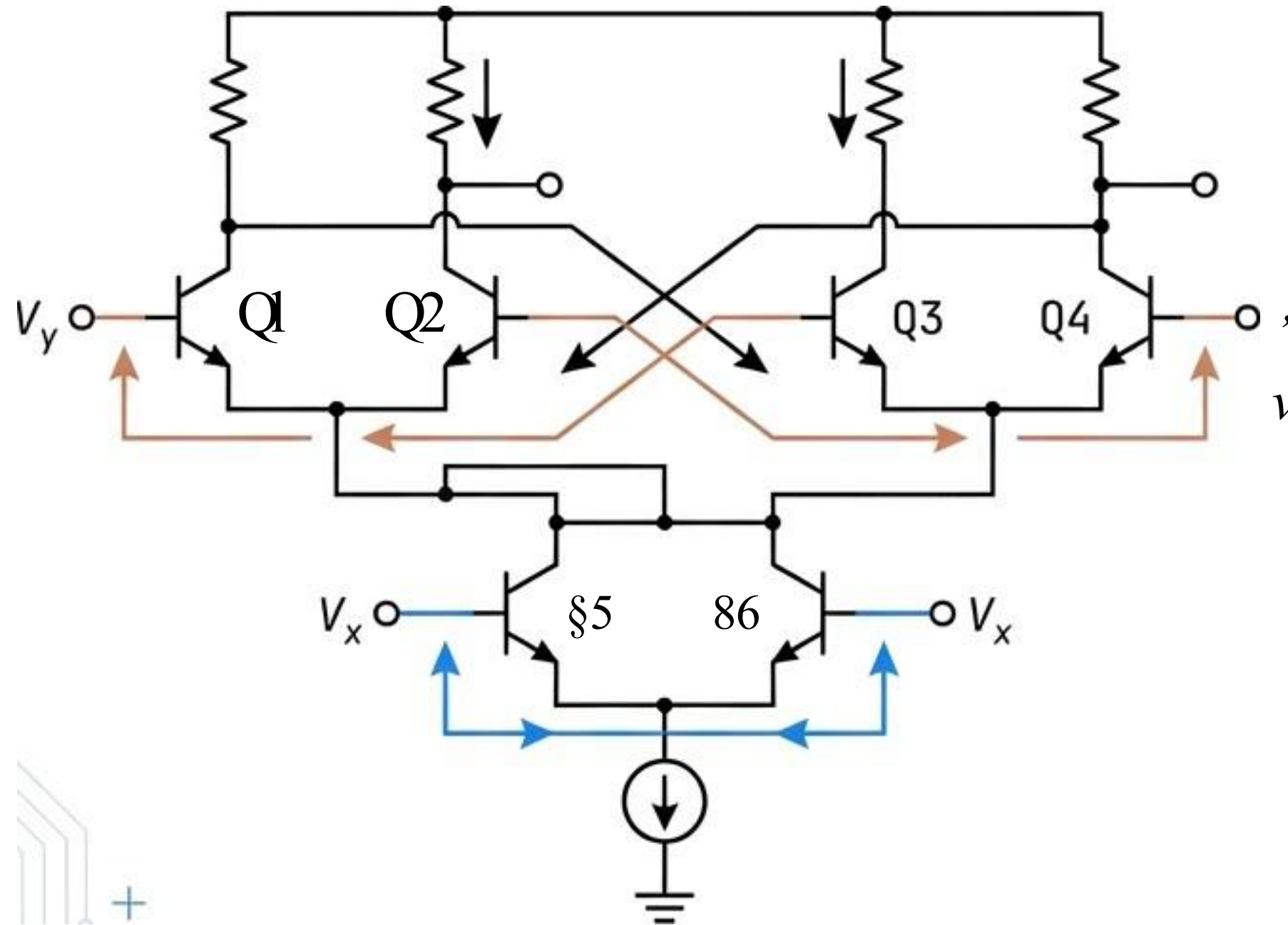

The Heart of the IC.

Inventor: Barrie Gilbert

Emitter Coupled Transistor Pairs exploiting the linear relationship between collector current and differential input voltage.

Performance Characterization

Test Results

- Accuracy: 0.5% to 1% (Full Scale)
- Bandwidth: Critical for RF Applications
- Feedthrough: Minimal leakage when one input is zero

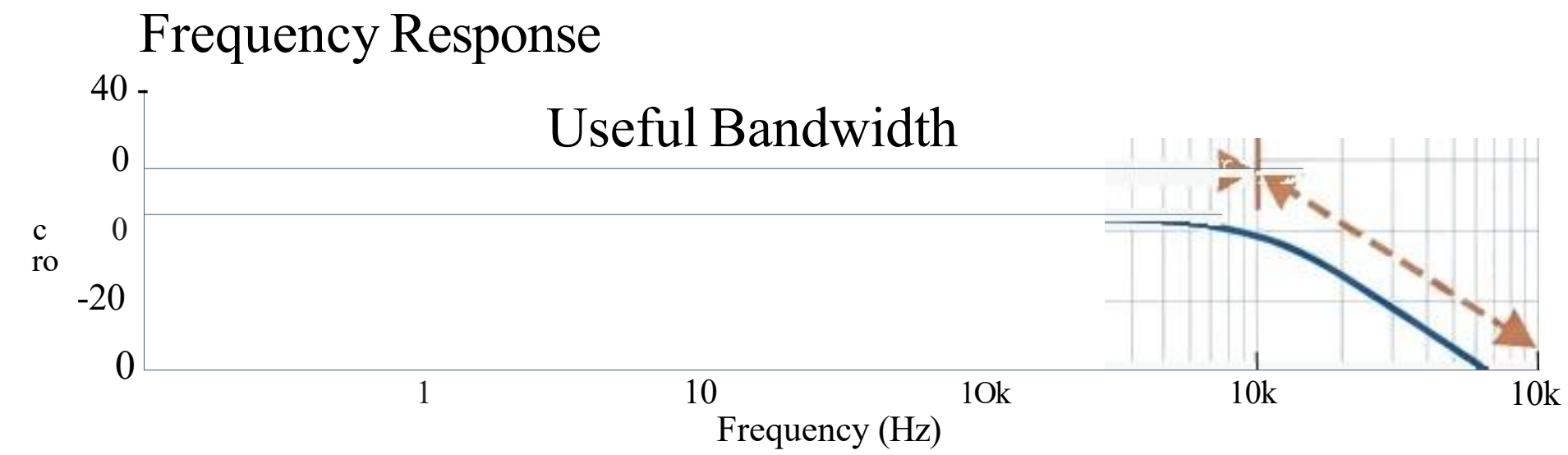
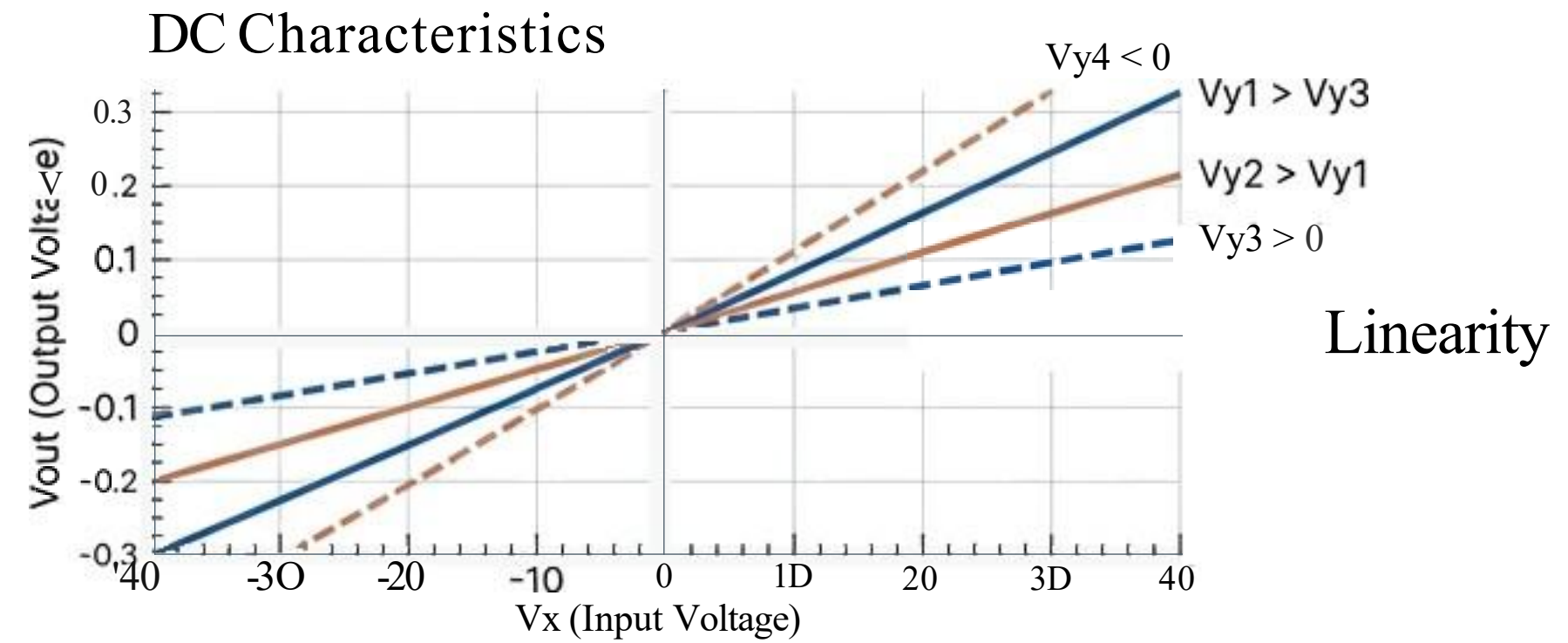

Application: Communications & PLLs

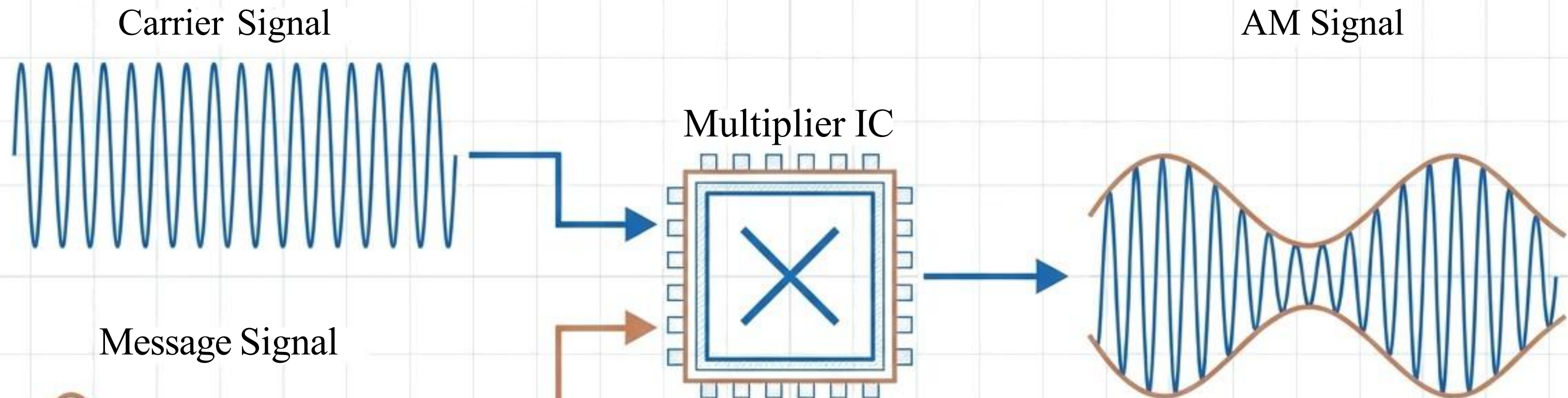

- Function: Modulation & Heterodyning.
- Key Usage: Essential component in Phase Locked Loops (PLL) for AM Detection.

Application: Analog Computation

Squaring Circuit

Frequency Doubler

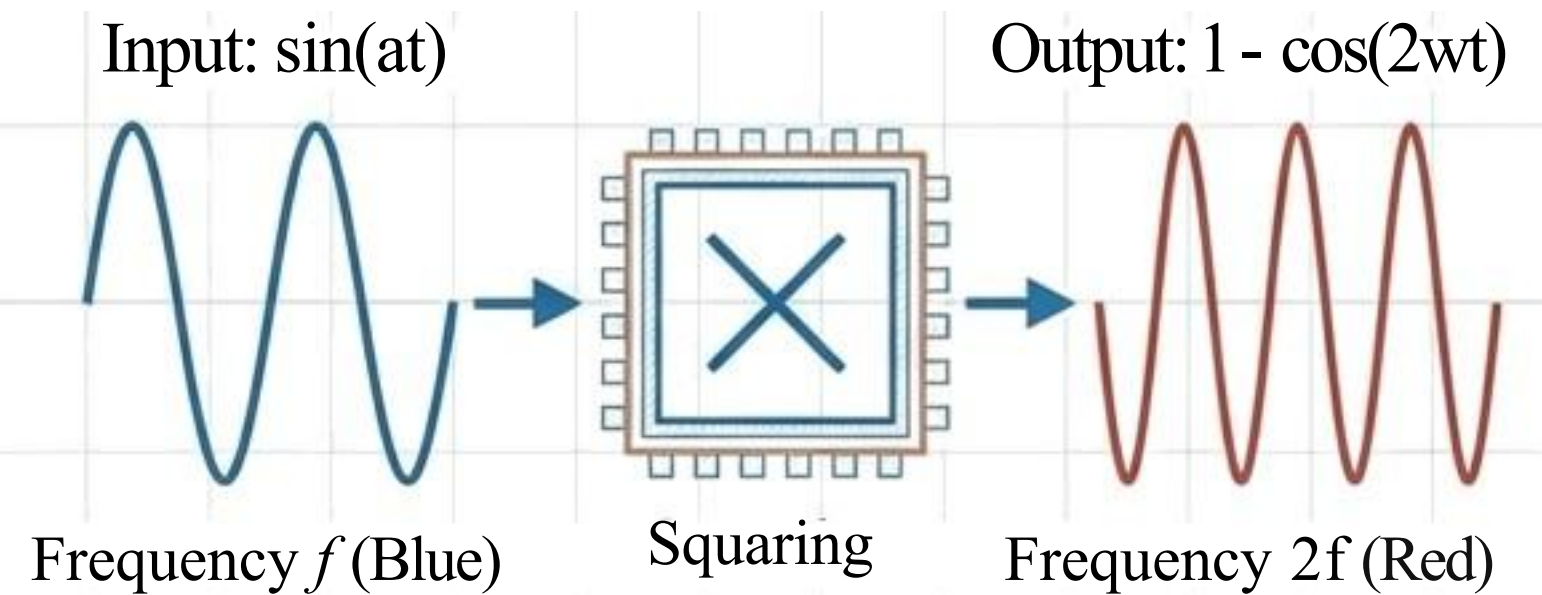
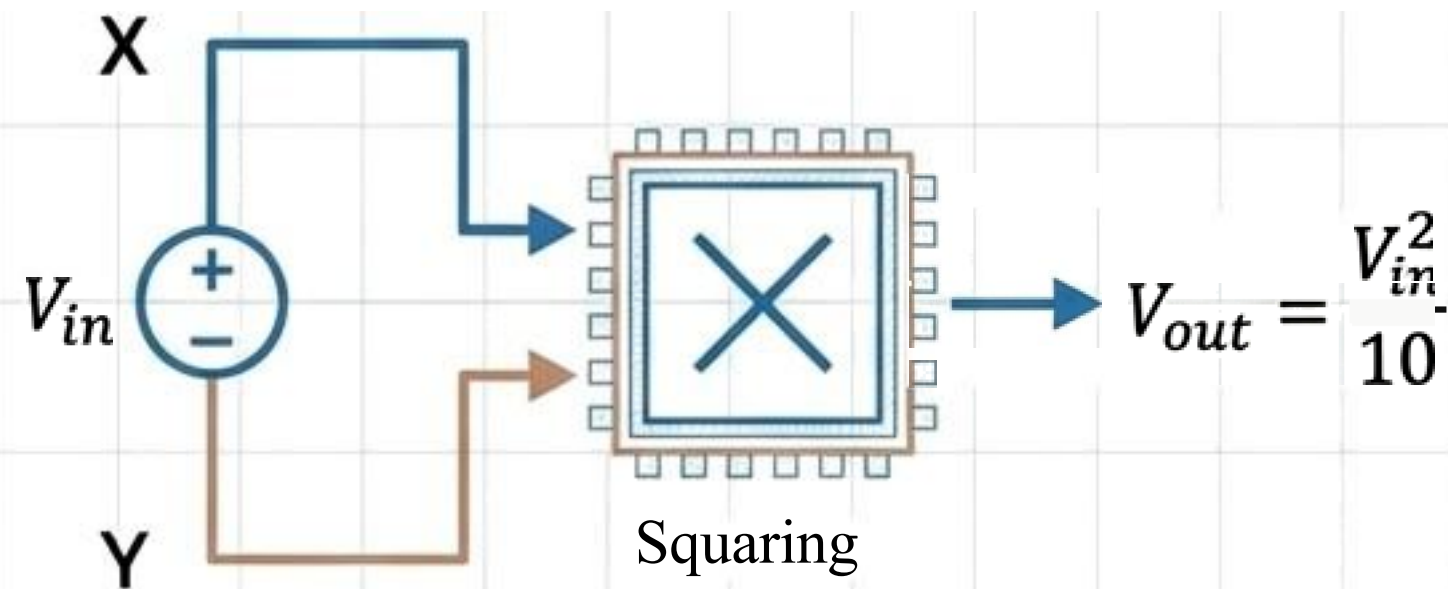

Use Case: RMS Calculation, Power measurement.

Hath: $\sin^2(wt) + 1 - \cos(2wr)$

Activity: Design a Power Meter

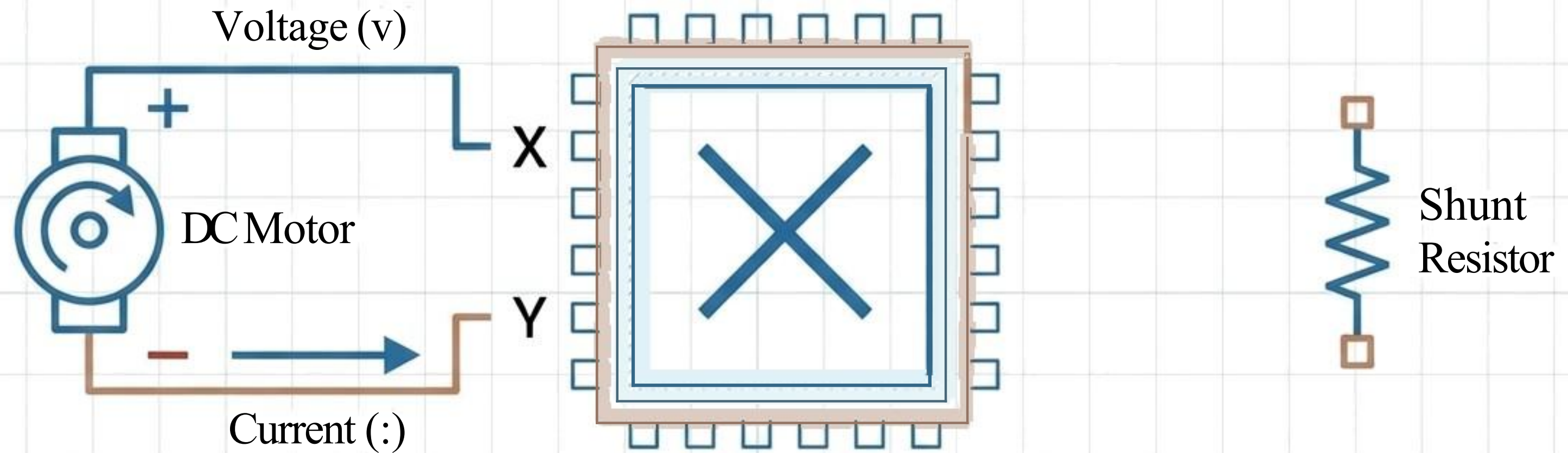

Challenge: Connect the components to measure Instantaneous Power (#).

Recall: $P = V \times I$

Summary-MIND MAP

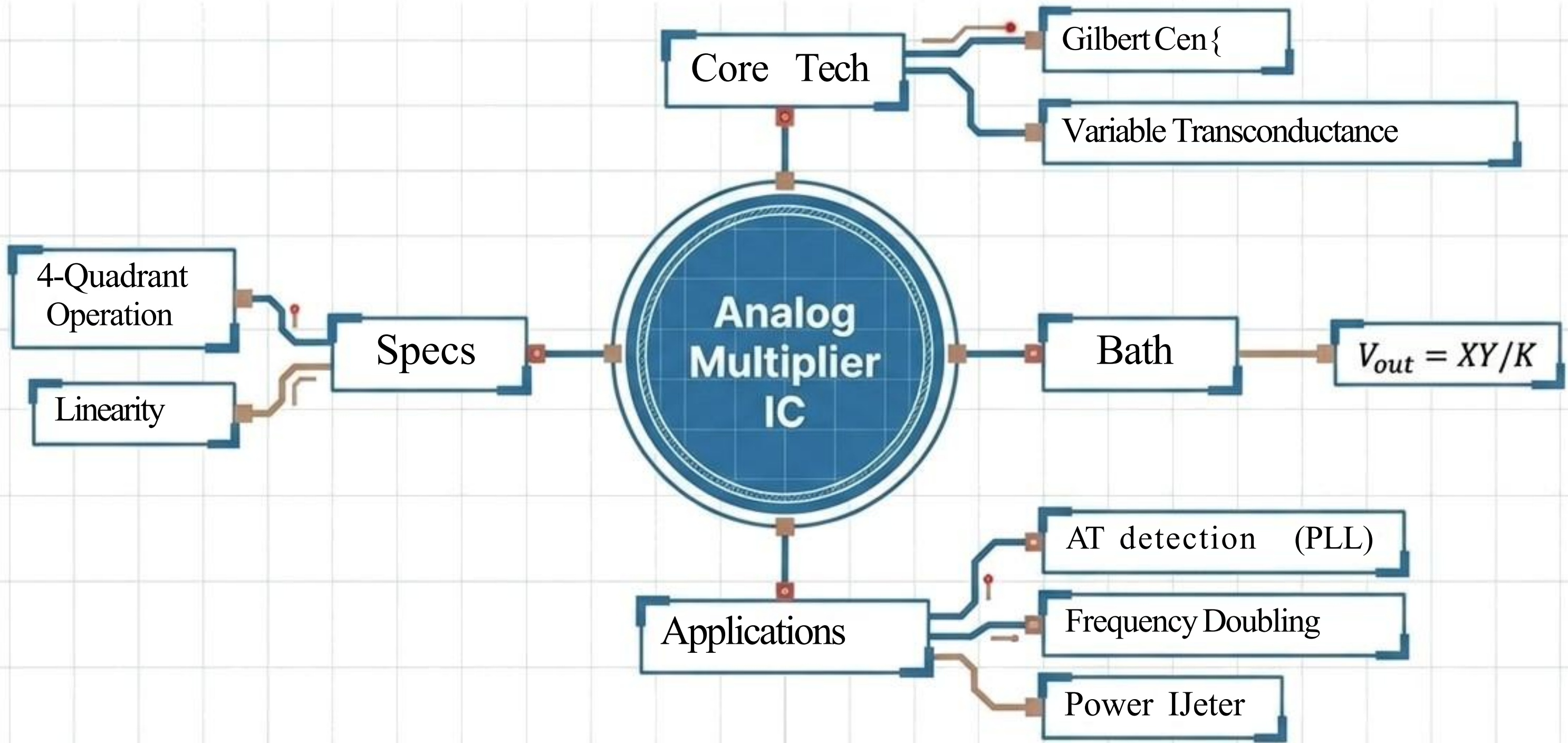

Assessment

Q1: Which transistor configuration forms the core of most analog multiplier ICs?

(The Gilbert Cell / Emitter Coupled Pair)

Q2: If both inputs to a multiplier are negative, what is the polarity of the output?

(Positive - 4 Quadrant Operation)

Q3: What is the primary application of multipliers in Phase Locked Loops as per the syllabus?

(AM Detection)

References & Further Reading

Textbooks:



1. "Linear Integrated Circuits" - D. Roy Choudhry, Shazi
3rd Edition. New Age International Pvt. Ltd., 5th Edition
(2018).



2. "Design with Operational Amplifiers and Analog
Integrated Circuits" - Sergio Franco. Tata McGraw-
Hill, 4th Edition (2014).

THANK YOU