

SNS COLLEGE OF TECHNOLOGY



(An Autonomous Institution)

Approved by AICTE, New Delhi, Affiliated to Anna University, Chennai

Accredited by NAAC-UGC with 'A++' Grade (Cycle III) &

Accredited by NBA (B.E - CSE, EEE, ECE, Mech & B.Tech.IT)

COIMBATORE-641 035, TAMIL NADU

DEPARTMENT OF ELECTRONICS AND COMMUNICATION ENGINEERING

Course Name: 23ECT203 LINEAR INTEGRATED CIRCUITS

II YEAR/VI SEMESTER

UNIT III –ANALOG MULTIPLIER AND PLLR

Topic : Variable transconductance technique

Introduction to Variable Transconductance

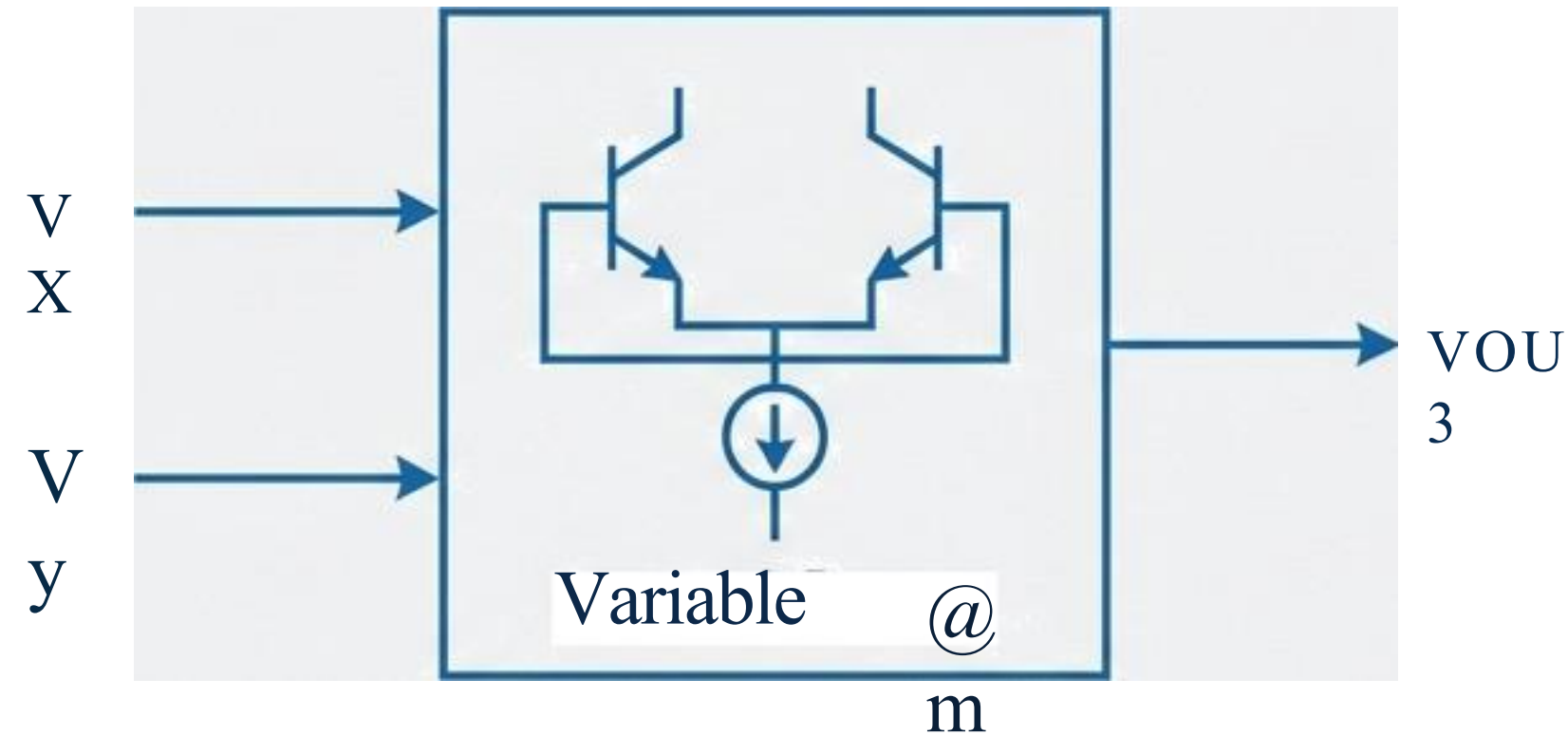

$$V_{out} = K V_x V_y$$

Scaling Factor (typically 0.1)

Core Concept: The dominant method
Monolithic Analog Multipliers
Cells).

Principle: Exploits the dependence for
of transistor transconductance (g_m) (e.g., Gilbert
on emitter bias current (IEE).

Phase : Empathize (The Design Problem)

The Pain

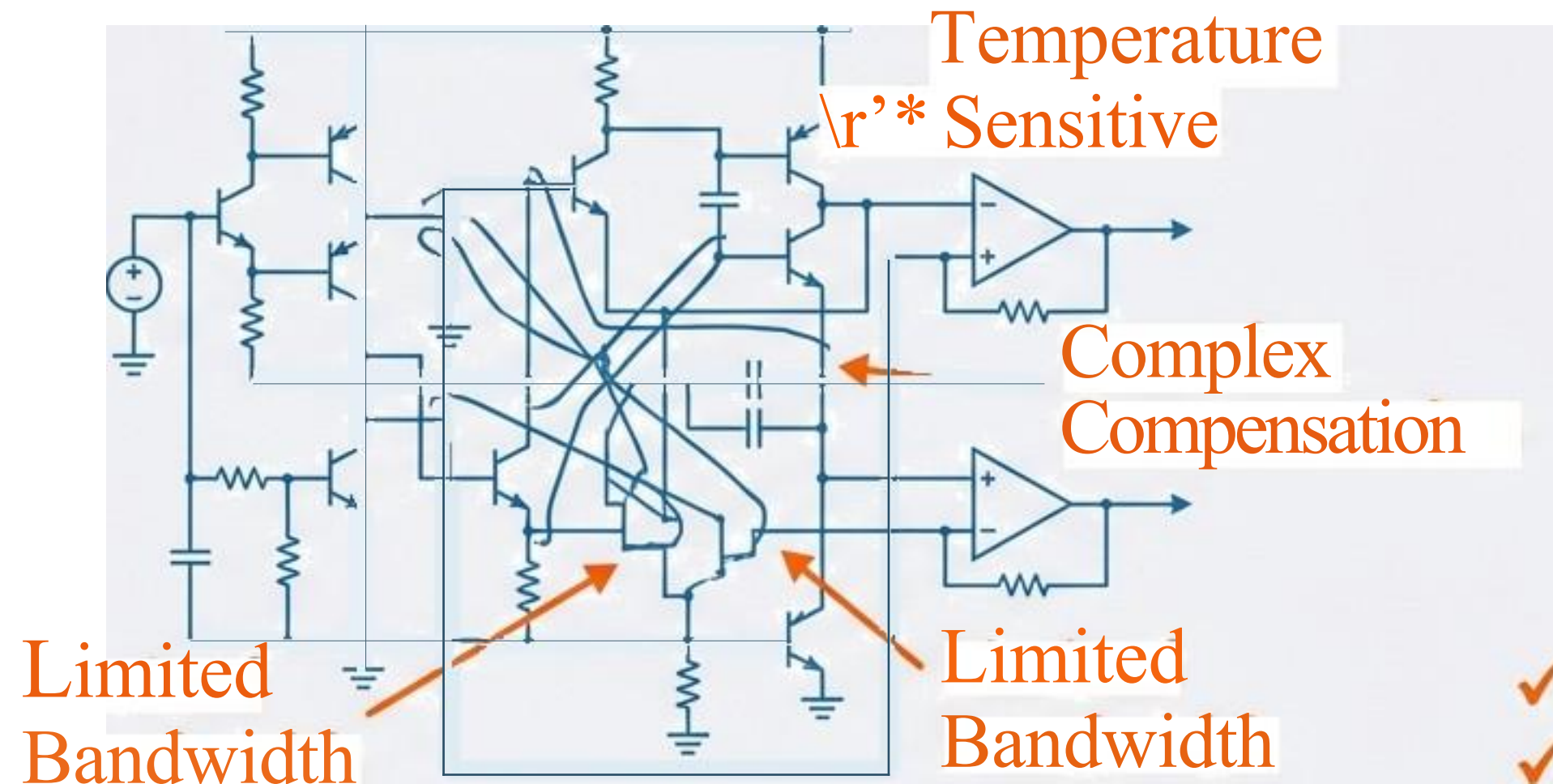

The Need

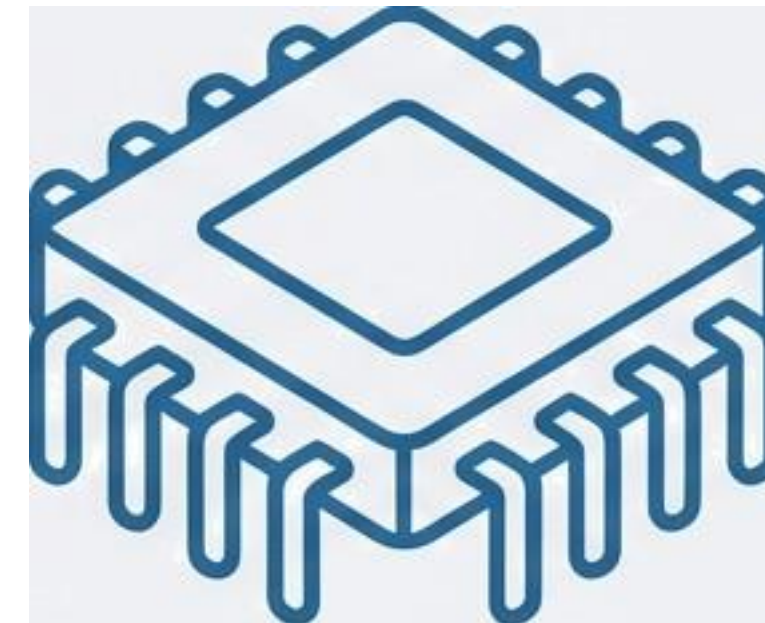

- ✓ - High Speed (Wide Bandwidth)
- ✓ - Monolithic Integration
- Temperature Stability

Log-Antilog Amplifiers

Problem Statement: Analog multiplication is mathematically simple but electrically complex. old methods fail at speed and stability.

Phase 2: Define (The Objective)

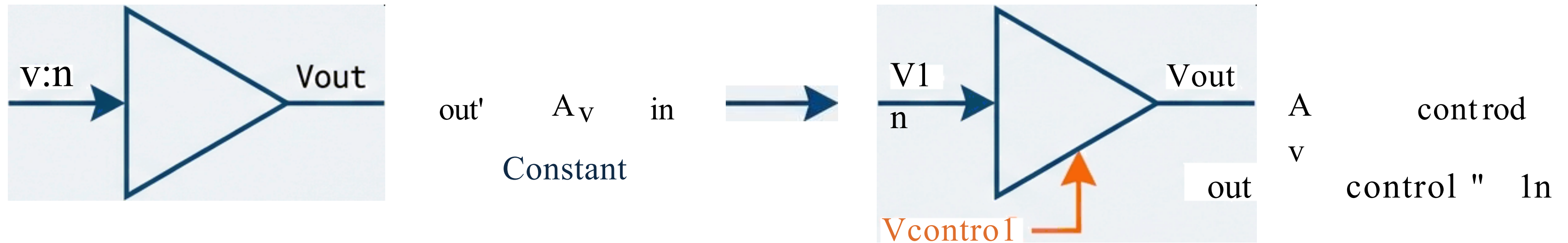

The Definition: Design a circuit stage where the voltage gain is linearly controlled by an external current or voltage source.

If Gain is variable, Amplification becomes Multiplication.

Phase 4: Prototype (The Circuit)

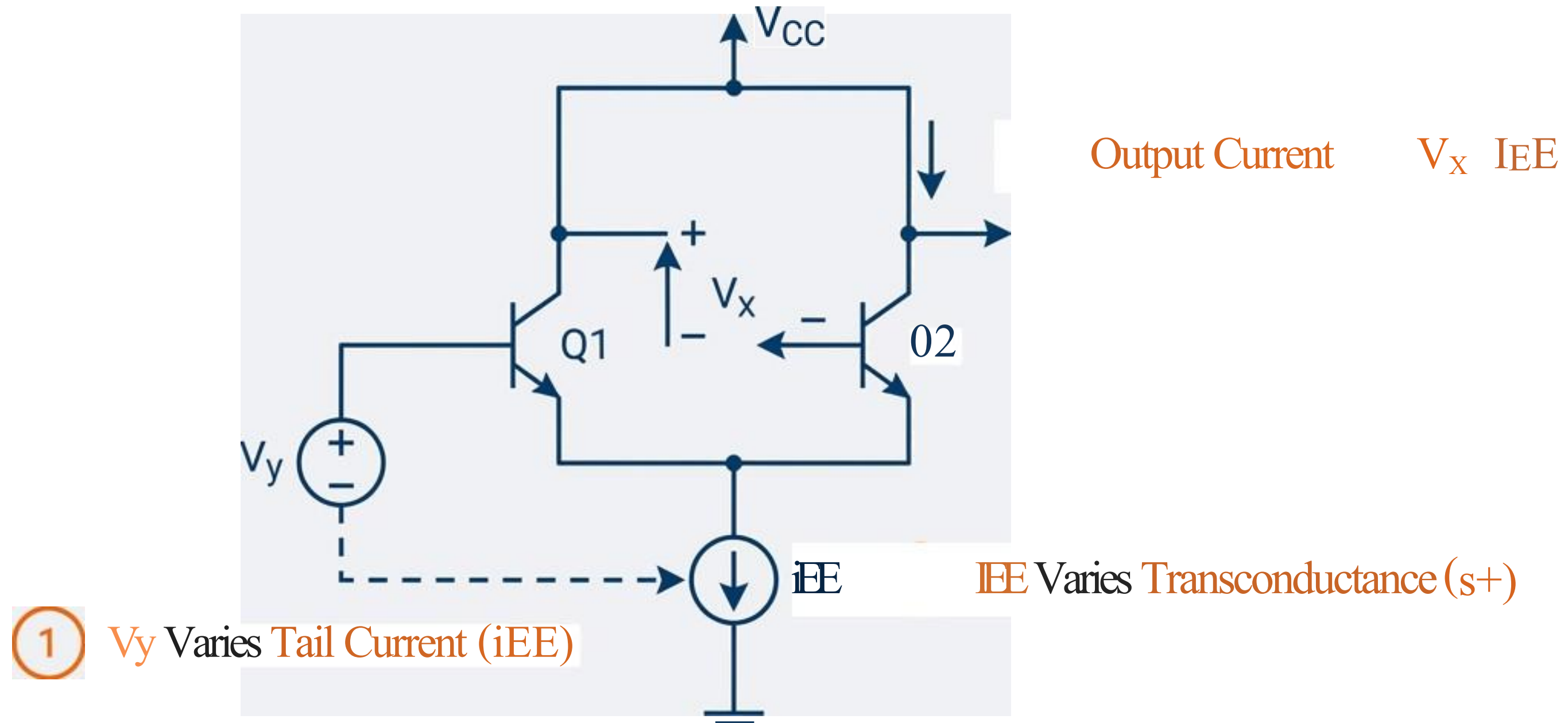

Phase 5: Test (Verification & Ouadrants)

Linearity Check

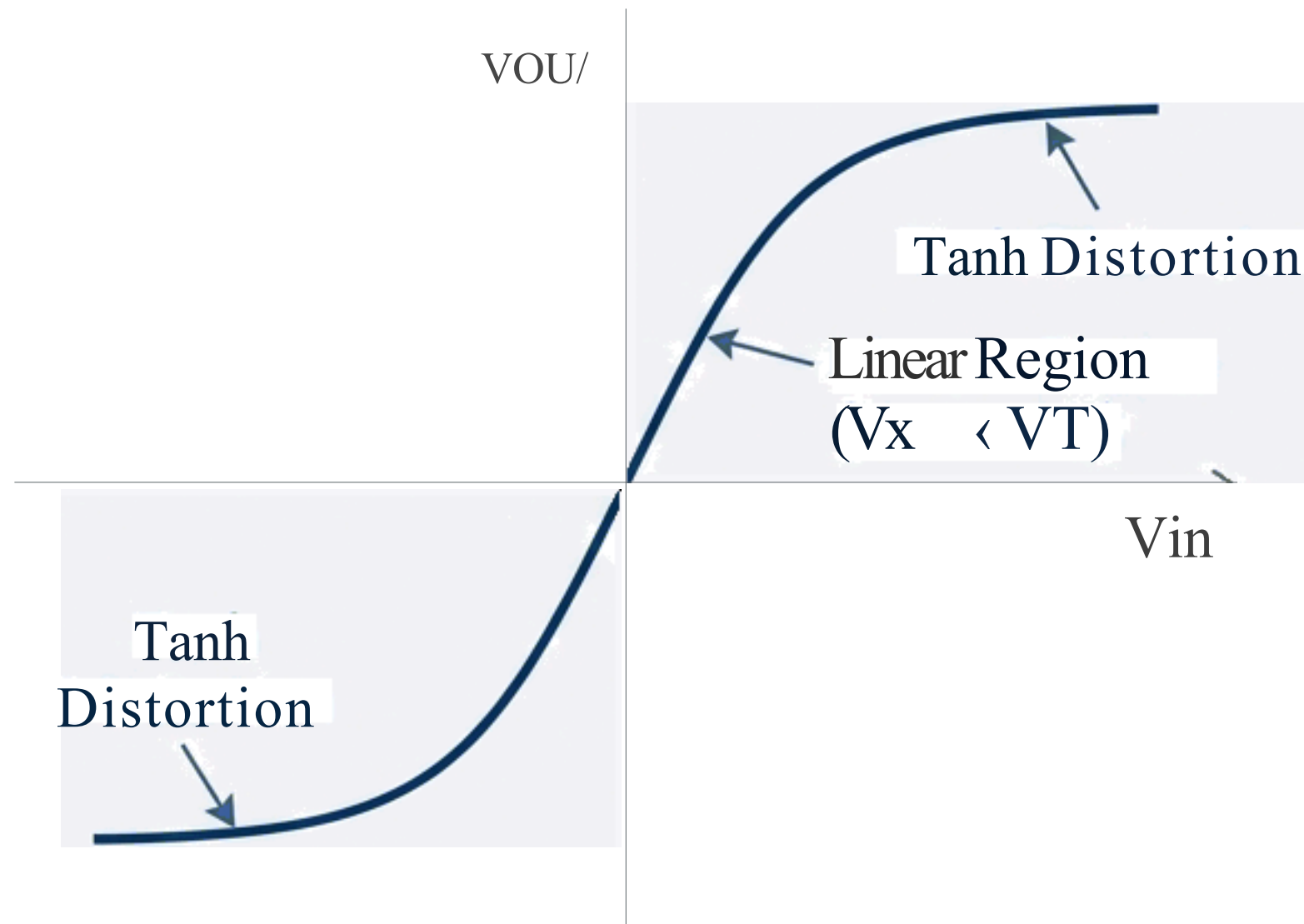

Quadrant Operation



- Single Pair: IEE must be positive (Unipolar Y input).
- Gilbert Cell: Cross-coupled pairs allow Bipolar X and Y inputs.

Key Parameters

Scale Factor (K)	$V_{out} = (V_x - V_y) / 10$	Standard $K = 0.1 \text{ V}^{-1}$
Accuracy	0.1% to 1% error	Trimmed via laser wafer adjustment
Bandwidth	High (MHz to GHz)	Superior to Log-Antilog
Feedthrough	Signal leakage when Input = 0	Ideally Zero

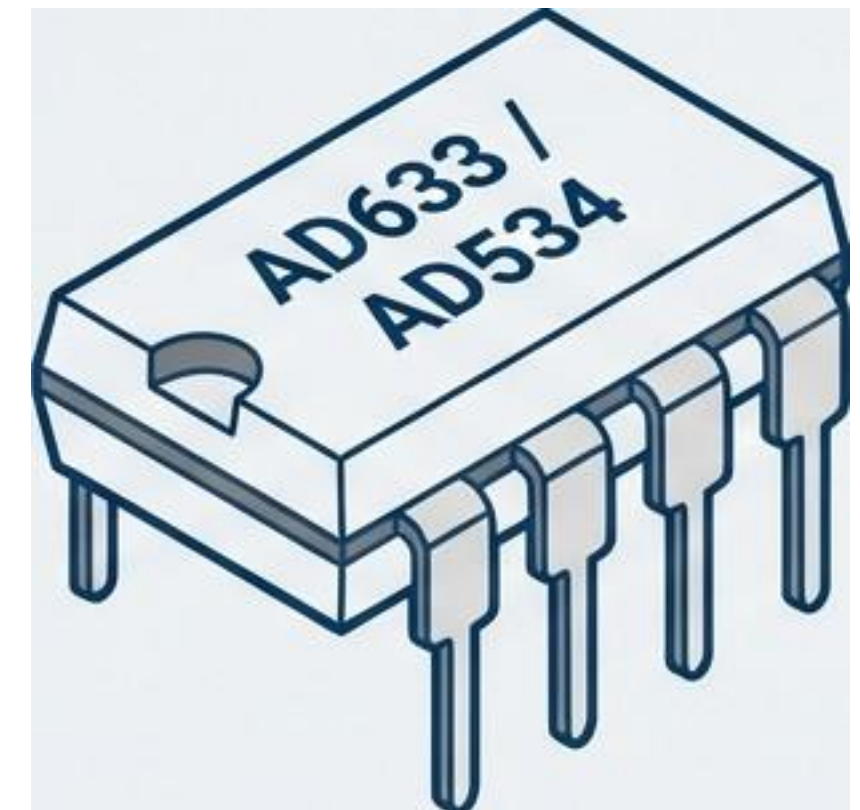

Limitations of the Technique



Small Signal Restriction

Base inputs must be small (mV range) to avoid Tanh nonlinearity. Solution: Pre-distortion diodes.

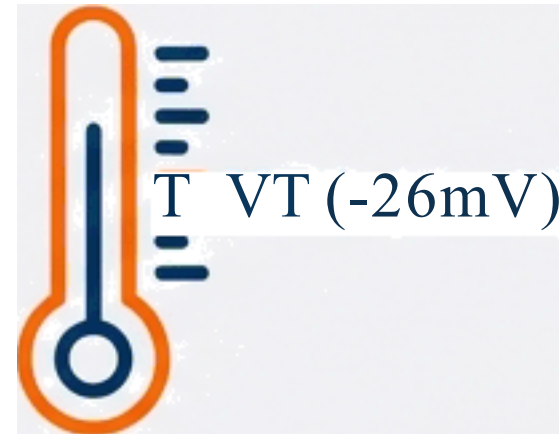

Temperature Dependence

V_T (-26mV) varies with Temperature. Gain drifts if not compensated internally.

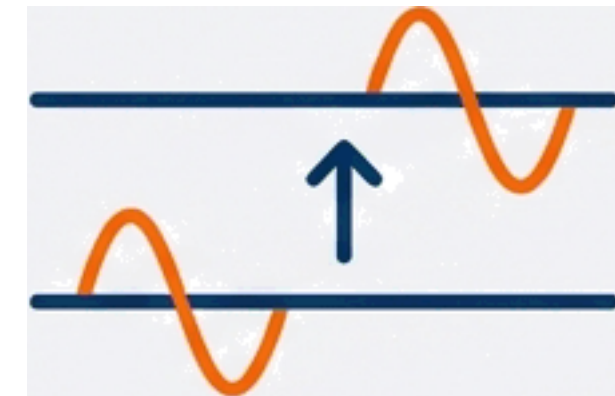

Offset Voltages

Transistor mismatches cause DC offsets, which result in output errors.

Applications & ICs

Communications

- Balanced Modulators
- Demodulators(AM)
- Frequency Mixers

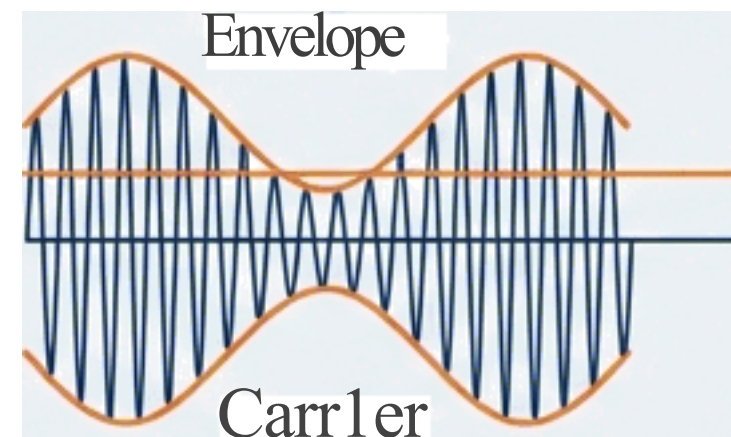

Signal Processing

- Voltage Controlled Amplifiers(VCA)
- Automatic Gain Control(AGC)

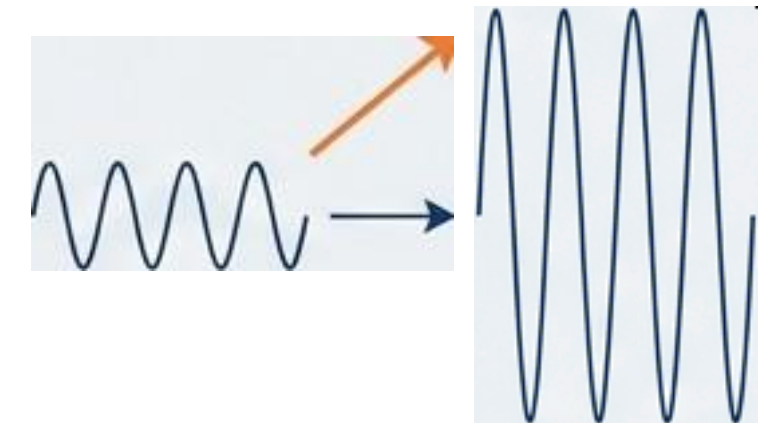

Computation

- Squaring (X^2)
- Square-rooting
- RBS Calculation

$$X^2 \quad \left| \quad \sqrt{X} \quad \text{RN} \quad \sqrt{\frac{\int (x^2) dt}{T}}$$

Industry Standard ICs

- AD534
- AD633 (Analog Devices)

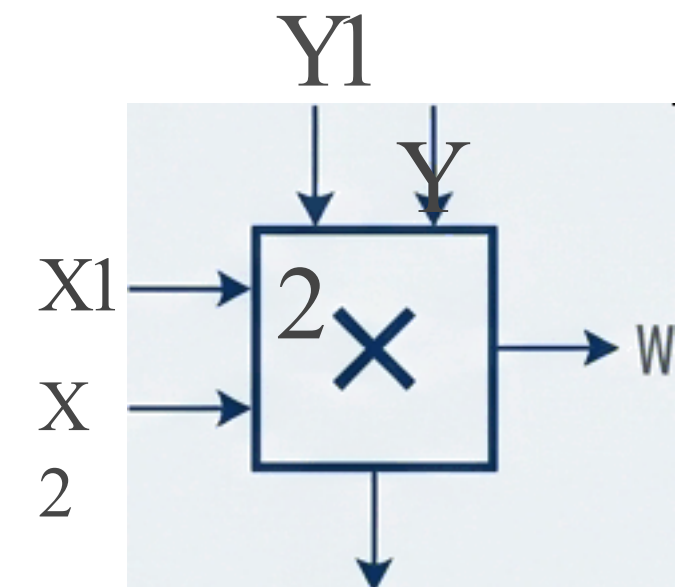

Class Activity: Compute the Output

Prompt:

- Scenario: Sense Factor $K = 0.1 \text{ V}^{-1}$
- Input X: $V_x = 2 \sin(\omega t)$ Volts
- Input Y: $V_y = +5$ Volts (DC)
- Task: Calculate V_{out} and identify the function.

Solution:

$$V_{out} = K \cdot V_x \cdot V_y$$

$$V_{out} = 0.1 \cdot (2 \sin \omega t) \cdot 5$$

$$V_{out} = 1.0 \sin(\omega t) \text{ Volts}$$

Function: Voltage Controlled Attenuation (Amplitude halved).

Summary Mind Map

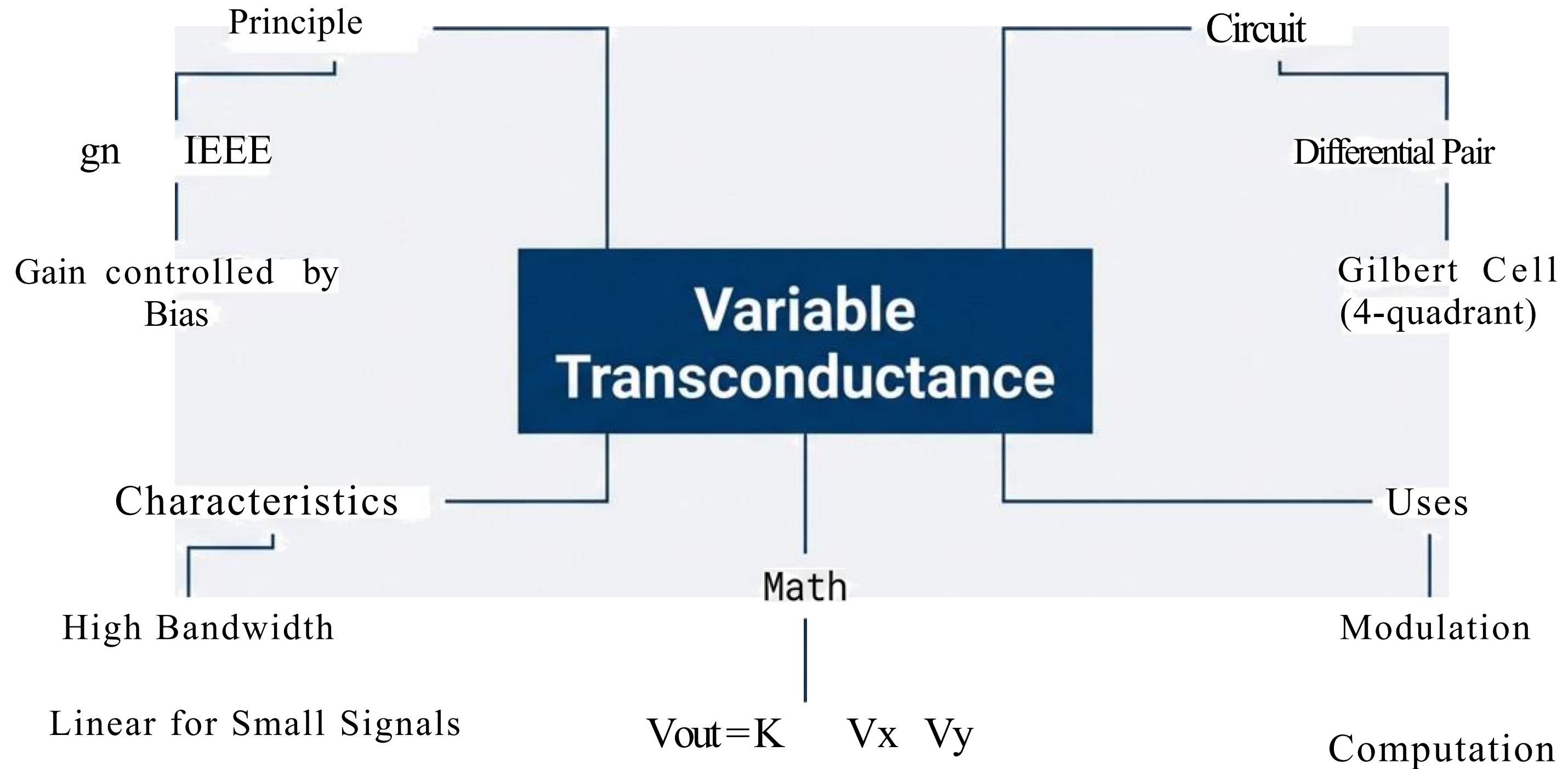

Assessment (Exam-Style Questions)

1. Define Transconductance in the context of an analog multiplier.
2. Why is the Variable Transconductance technique preferred over Log-Antilog methods for high-frequency applications?
3. Explain the difference between a 2-Quadrant and a 4-Quadrant multiplier .
4. What condition is required for the differential pair to operate linearly? (Answer: $V_{in} \ll V_T$) .

References

Textbooks:

- D. Roy Choudhry, Shail Jain, "Linear Integrated Circuits", New Age International Pvt. Ltd., Fifth Edition 2018.
- Sergio Franco, "Design with Operational Amplifiers and Analog Integrated Circuits", Fourth Edition, Tata McGraw-Hill, 2014.

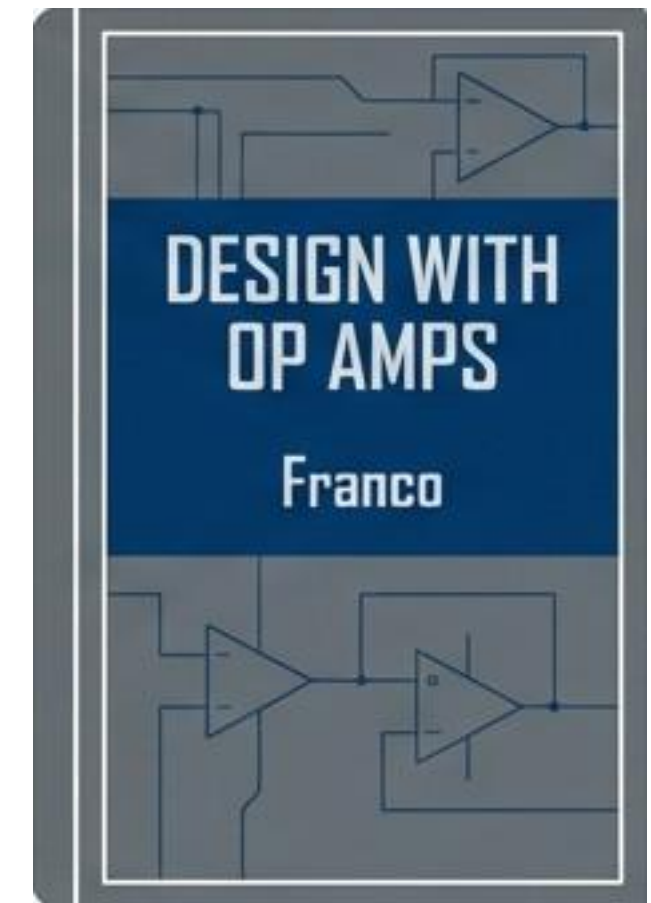
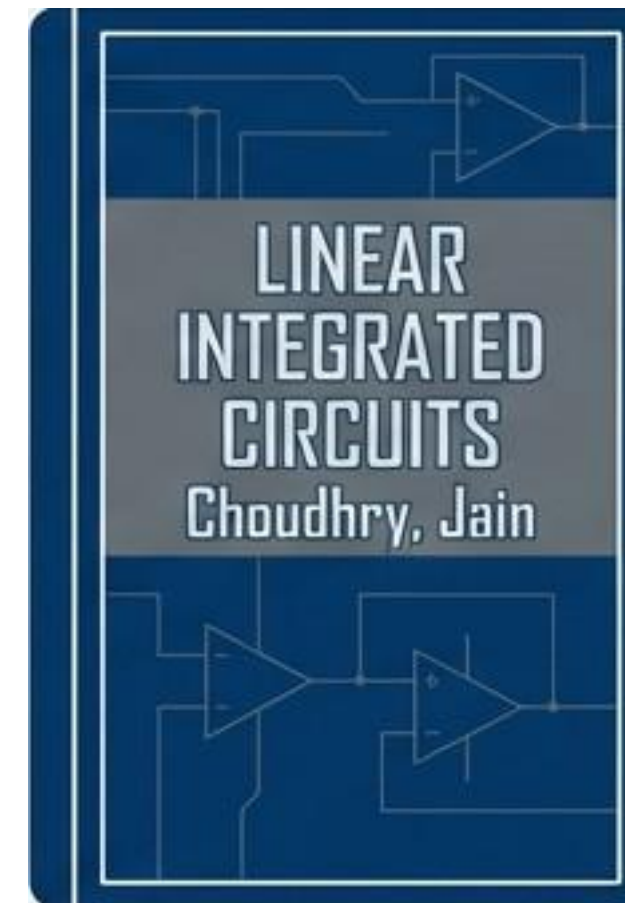

Thank You